

BENCHMARKS:
 BM #1: "C" Cut on the South
 Hubguard of R.C.B.C., 78' West
 of Ridge Road on South Side of
 37th Street North.
 Elev. = 1331.52 NGVD29

NOTES:

1. PROPOSED TOP OF FOUNDATION ELEVATIONS ARE SHOWN ON PLANS. CONTRACTOR TO SET FINISHED FLOOR AND GARAGE FLOOR ELEVATIONS. ALL STREET ELEVATIONS SHOWN ON PLANS ARE FOR TOP OF CURB (FULL-HEIGHT).
2. THIS GRADING PLAN IS DESIGNED WITH VIEW-OUTS AND WALK-OUTS. ELEVATIONS SHOWN AS XX.X V.O. DEPICT VIEW-OUT STRUCTURES. ELEVATIONS SHOWN AS XX.X W.O. DEPICT WALK-OUT STRUCTURES.
3. ALL LOTS SHALL MEET MINIMUM PAD REQUIREMENT AS SHOWN ON THE RECORDED PLAT.

MINIMUM BUILDING PAD ELEVATIONS FOR LOWEST OPENING TO THE STRUCTURES			
LOT	BLOCK	ELEVATION	
		CITY DATUM	NGVD29
1-29	A	145.6	1333.0

4. LOT DIMENSIONS HAVE BEEN OMITTED ON THIS PLAN. REFER TO THE RECORDED PLAT FOR FINAL DIMENSION, EASEMENT, & BUILDING SETBACK INFORMATION.
5. HOUSE PAD ELEVATIONS DEPICTED WITH BOLD OUTLINES AND NOTED WITH THIS SYMBOL ● INDICATE THAT DEEP FOOTINGS OR DEEP FOUNDATIONS MAY BE REQUIRED.
6. A DRAINAGE PLAN HAS BEEN DEVELOPED FOR THIS SUBDIVISION AND IS ON FILE WITH THE CITY OF WICHITA, KANSAS. DRAINAGE INTENT SHALL REMAIN AS DEPICTED OR AS MODIFIED WITH THE APPROVAL OF THE CITY ENGINEER OF THE CITY OF WICHITA, KANSAS. NO OBSTRUCTIONS WHICH IMPEDE THE FLOW OF THIS DRAINAGE PLAN SHALL BE ALLOWED.

7. ALL ELEVATIONS SHOWN ARE IN NGVD29.

8. NO BUILDING PERMITS ARE TO BE ISSUED FOR ANY LOTS THAT ARE LOCATED IN THE SPECIAL FLOOD HAZARD AREA WITHIN THIS PLATTED SUBDIVISION UNLESS ONE OF THE FOLLOWING CONDITIONS ARE MET.

A. THE LOWEST FLOOR (INCLUDING BASEMENT) IS CONSTRUCTED A MINIMUM OF 1 FOOT ABOVE THE DETERMINED BASE FLOOD ELEVATION.

OR

B. A LETTER OF MAP REVISION (LOMR) IS ISSUED BY THE FEDERAL EMERGENCY MANAGEMENT AGENCY (FEMA) REMOVING THE SUBJECT PROPERTY FROM THE SPECIAL FLOOD HAZARD AREA, WHICH WOULD THEN ALLOW BUILDINGS TO BE CONSTRUCTED WITH THE LOWEST OPENING AS SPECIFIED ON THIS GRADING PLAN AND MEETING FEMA TECHNICAL BULLETIN 10-01.

9. ALL LOTS IN THIS SUBDIVISION SHALL MEET THE CONDITIONS SPECIFIED IN FEMA TECHNICAL BULLETIN 10-01.

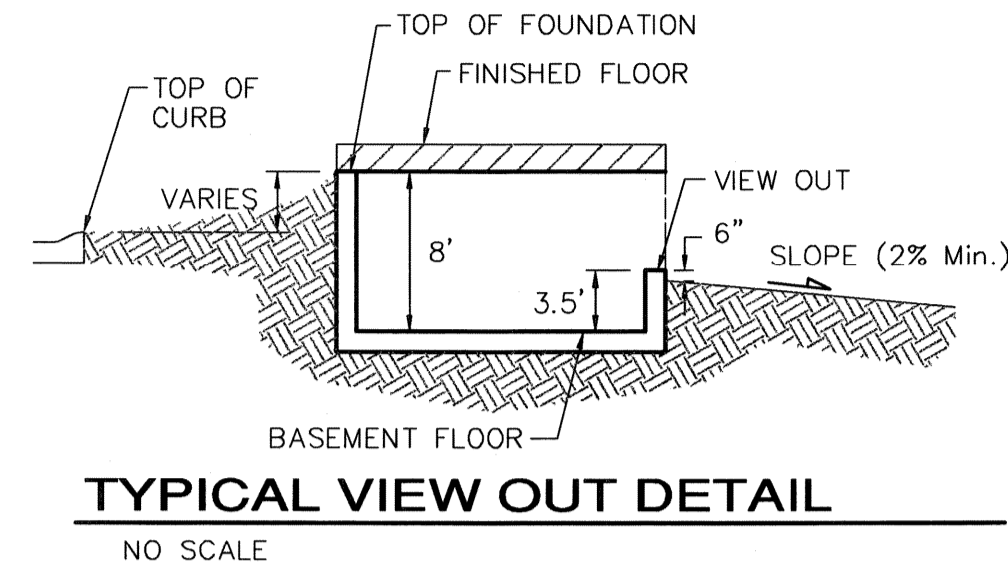

TYPICAL VIEW OUT DETAIL
 NO SCALE

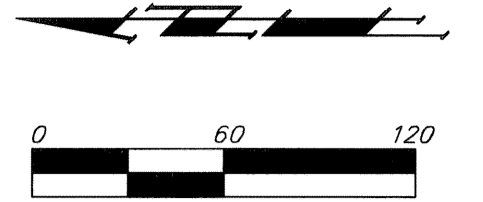

RESERVE "B"
 STATIC W.S. (GROUNDWATER) ~ 1321.0

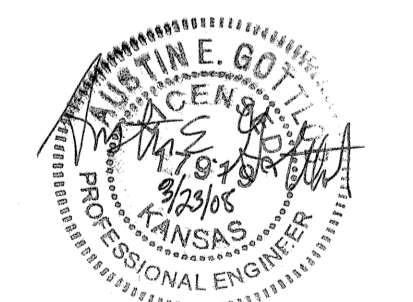
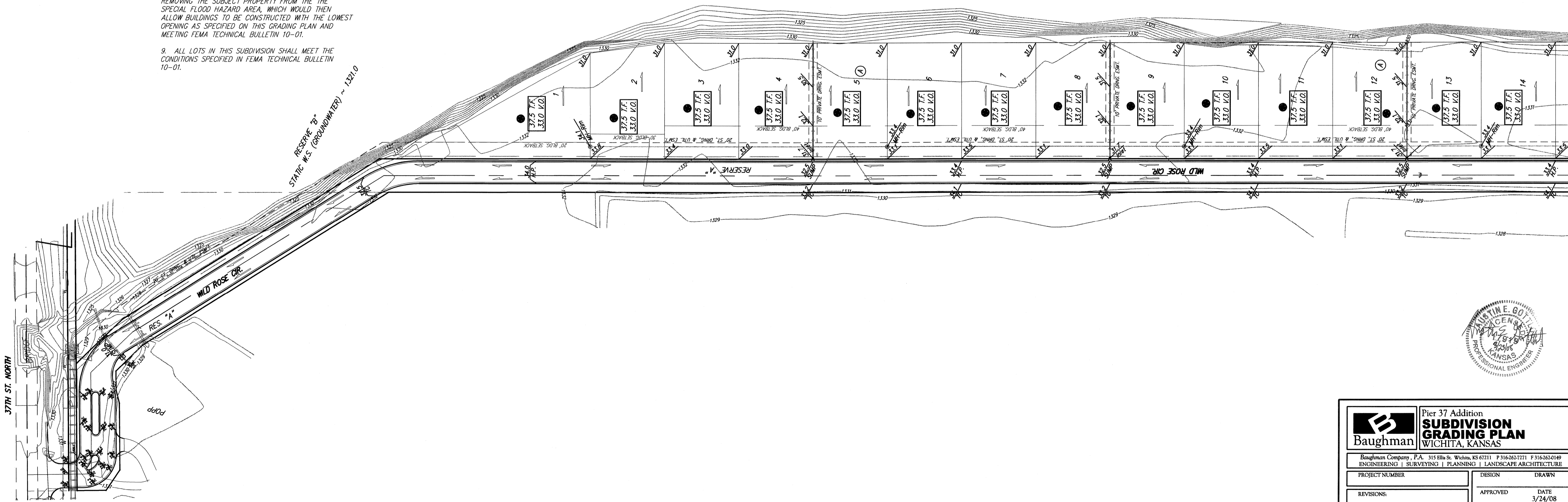

Baughman		Pier 37 Addition SUBDIVISION GRADING PLAN WICHITA, KANSAS	
Baughman Company, P.A. 315 Ellis St. Wichita, KS 67211 P 316-262-7271 F 316-262-0149 ENGINEERING SURVEYING PLANNING LANDSCAPE ARCHITECTURE			
PROJECT NUMBER	DESIGN	DRAWN	
REVISIONS:	APPROVED	DATE	3/24/08
	SCALE	Noted	
	SHEET	1 OF 2	