

Regrade R.O.W. as necessary for positive drainage

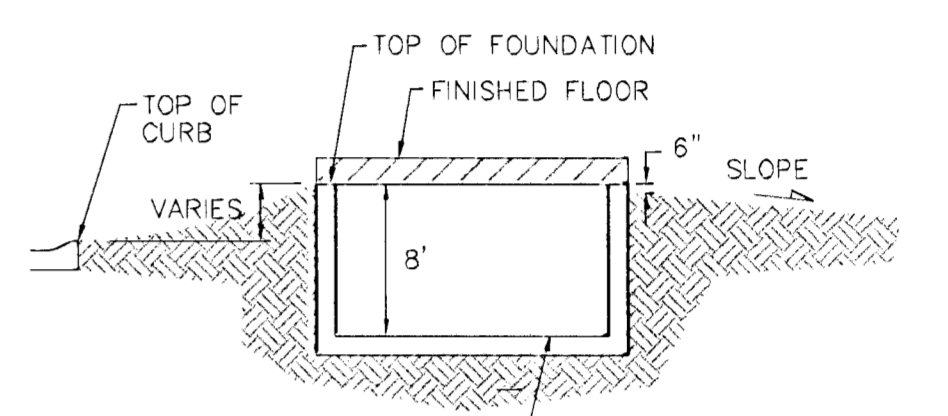

TYPICAL NON-VIEW OUT DETAIL  
NO SCALE

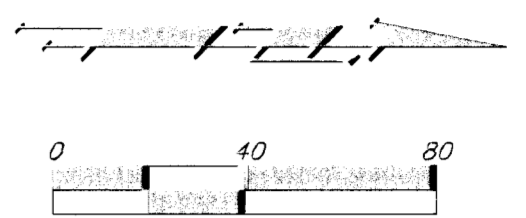
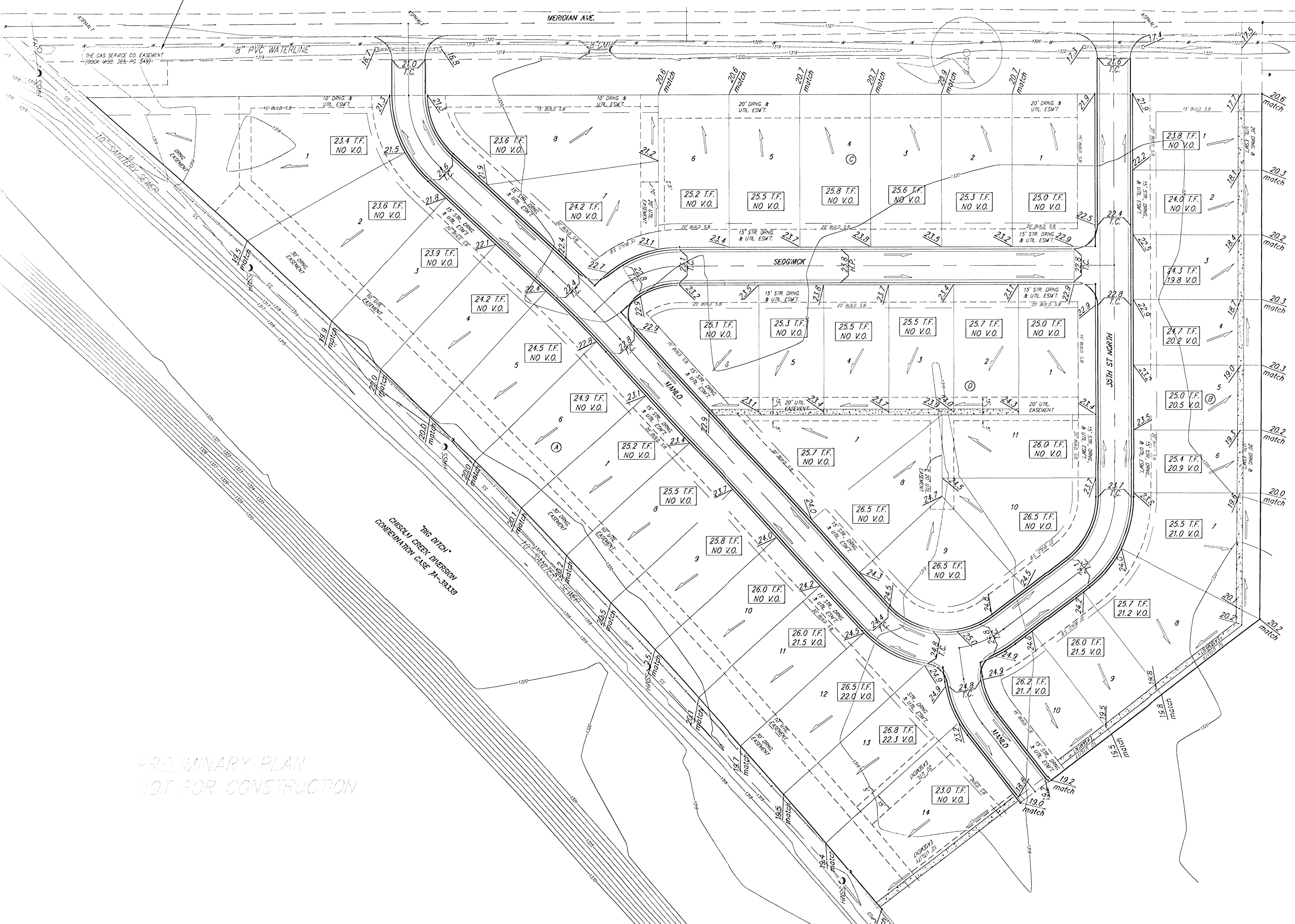
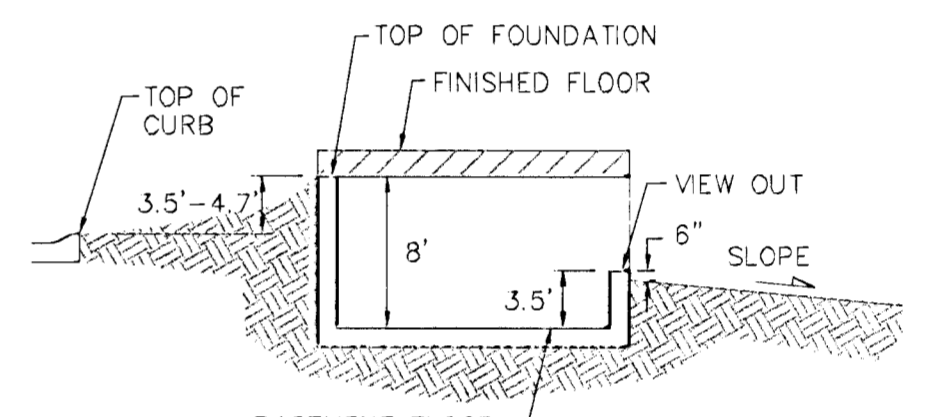

TYPICAL VIEW OUT DETAIL  
NO SCALE

**NOTES:**

Proposed Top of Foundation Elevations Are Shown On Plans. Contractor to Set Finished Floor Elevations.

All Street Elevations Shown on Plans Are for Top of Curb (Full-Height).

This Grading Plan is Designed with View-Outs. Elevations Shown at Rear of House (XX.X V.O.)

Lot dimensions have been omitted on this plan, refer to the recorded plat for this information.

\* May Require Extra Deep Foundation

\*\*Shallow Sanitary Sewer Depths, Builder to Verify Sanitary Sewer Depths Prior to Construction to Ensure Basement Service

PRELIMINARY PLAN  
NOT FOR CONSTRUCTION

		<b>MESA VERDE ADDITION</b> <b>GRADING PLAN</b>	
		<small>Baughman Company, P.A. 315 Ellis St. Wichita, KS 67111 F3162427171 F316242189          ENGINEERING   SURVEYING   PLANNING   LANDSCAPE ARCHITECTURE</small>	
PROJECT NUMBER	DESIGN	BLG	DRAWN
REVISIONS:	APPROVED	DATE	08/18/04
		SCALE	noted
		SHEET	1 OF 1