

**MACHINES INTERNATIONAL
1240 W. MACARTHUR
WICHITA, SEDGWICK COUNTY, KANSAS**

BENCH MARK: C.O.W. Bench Mark on 2'x2' conc. base, S.W. Cor. KG&E Tower, 176' W. & 53' N. of Centerline Intersection of Seneca St. & Mac Arthur Rd. Stamped DLK 7-93 Elev.=91.99 (City Datum)

ON SITE B.M.: R.R. Spike in Power Pole 41.1' W. of S.E. Cor. of Subject Property. Elev.=93.20 (City Datum)

Note: Blanket easement granted to Kansas Gas and Electric Company in Book Misc. 161, Page 228, over Subject Property.

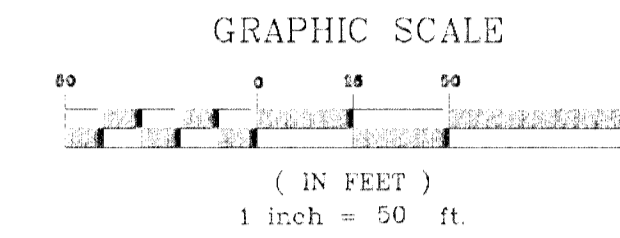

GENERAL NOTES

1. The Contractor shall provide a minimum advance notice of 48 hours to utility companies prior to starting construction as follows:

KANSAS ONE CALL 1-800-344-7233 or 687-2470 (LOCAL WICHITA)

The Contractor must notify the following in the event of an emergency:

| | |
|---------------------------------|----------------------|
| Cox Communications | 262-4270 or 263-2061 |
| SBC | 1-571-2611 |
| Kansas Gas Service | 832-3168 |
| Westar | 261-6824 |
| Aquila | 1-800-303-0752 |
| City of Wichita (Water & Sewer) | 268-4555 |

2. Pavement grades shown are to the top of pavement.

3. Existing elevations were provided by others. Contractor shall verify existing grades and notify Engineer of any discrepancies. Elevations are based on City Datum (Mean Sea Level-1187.4).

4. Contractor shall be responsible for establishing and protecting Benchmark throughout construction.

5. Contractor shall strip site of topsoil (6" min.) and stockpile this material to be used in grassed areas.

6. Curb in front of building shall be 6" drop down edge curb. All other curb shall be Combined Curb & Gutter.

7. Compaction of fill material and subgrade stabilization shall comply with Geotechnical Engineering Report.

8. Pavement type shall be as designated by the owner. Pavement thickness shall be according to the Geotechnical Engineering Report.

9. All soil used for overexcavation and for backfilling of excavations for basement, tank removal etc. shall be tested for compaction as required by an independent Soils Engineer's recommendations.

10. The Contractor shall examine the construction site before bidding and be satisfied as to the work shown for completion. After bids have been received, the Contractor shall not assert that there was a misunderstanding of the quantities of work or of the nature of work to be completed.

11. All proposed slopes and grades shall be in accordance with ADA Sec. 4.1.3(8)(a)(ii).

OWNER:
Morgan Land & Development
Company LLC

SITE ADDRESS:
1240 W. MacArthur Road
Wichita, Kansas 67217
Ph.: Not Available

GROSS SIZE:
221,066.54 Sq. Ft. ±
5.07 Acres ±

NET SIZE:
219,765.89 Sq. Ft. ±
5.05 Acres ±

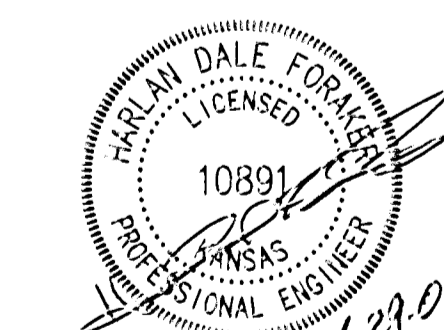

SITE GRADING PLAN PREPARED BY:
CERTIFIED ENGINEERING DESIGN, P.A.
810 WEST DOUGLAS, SUITE C
WICHITA, KANSAS 67203
PH: (316) 262-8808
FAX: (316) 262-1669

SHEET 1
TOTAL 1

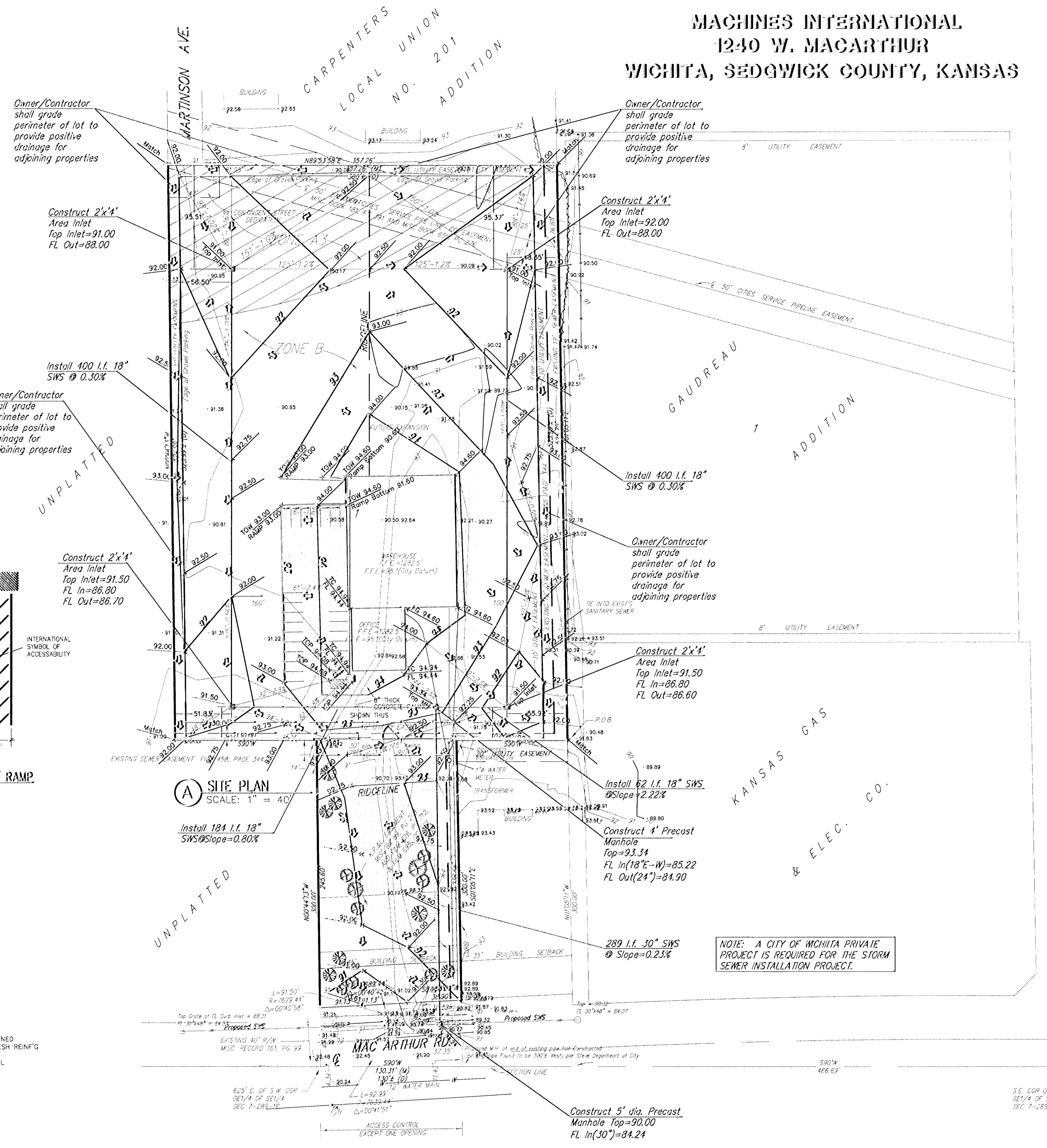

ACCESSIBILITY NOTES:
ALL PARKING STALLS, SIGNAGE, RAMPS, etc. SHALL MEET THE REQUIREMENTS OF THE "AMERICANS WITH DISABILITIES ACT", CHAPTER 11 OF THE 2006 I.B.C. and LOCAL ACCESSIBILITY CODES

PAVING SLOPE NOTES:
a) CURB RAMP w/ RUNNING SLOPE SHALL NOT EXCEED 1:12 and MAXIMUM CROSS SLOPE OF 1:50 - SIDE FLARES SHALL NOT EXCEED 1:12 SLOPES.
b) PARKING SPACES and ACCESS AISLE SHALL HAVE MAXIMUM CROSS SLOPES OF 1:50 IN ANY DIRECTION.
c) ALL PATH OF TRAVEL ACCESS SHALL HAVE MAXIMUM CROSS SLOPES TO 1:50
d) RUNNING SLOPE SHALL NOT EXCEED 1:20 UNLESS INDICATED AS A CURB RAMP

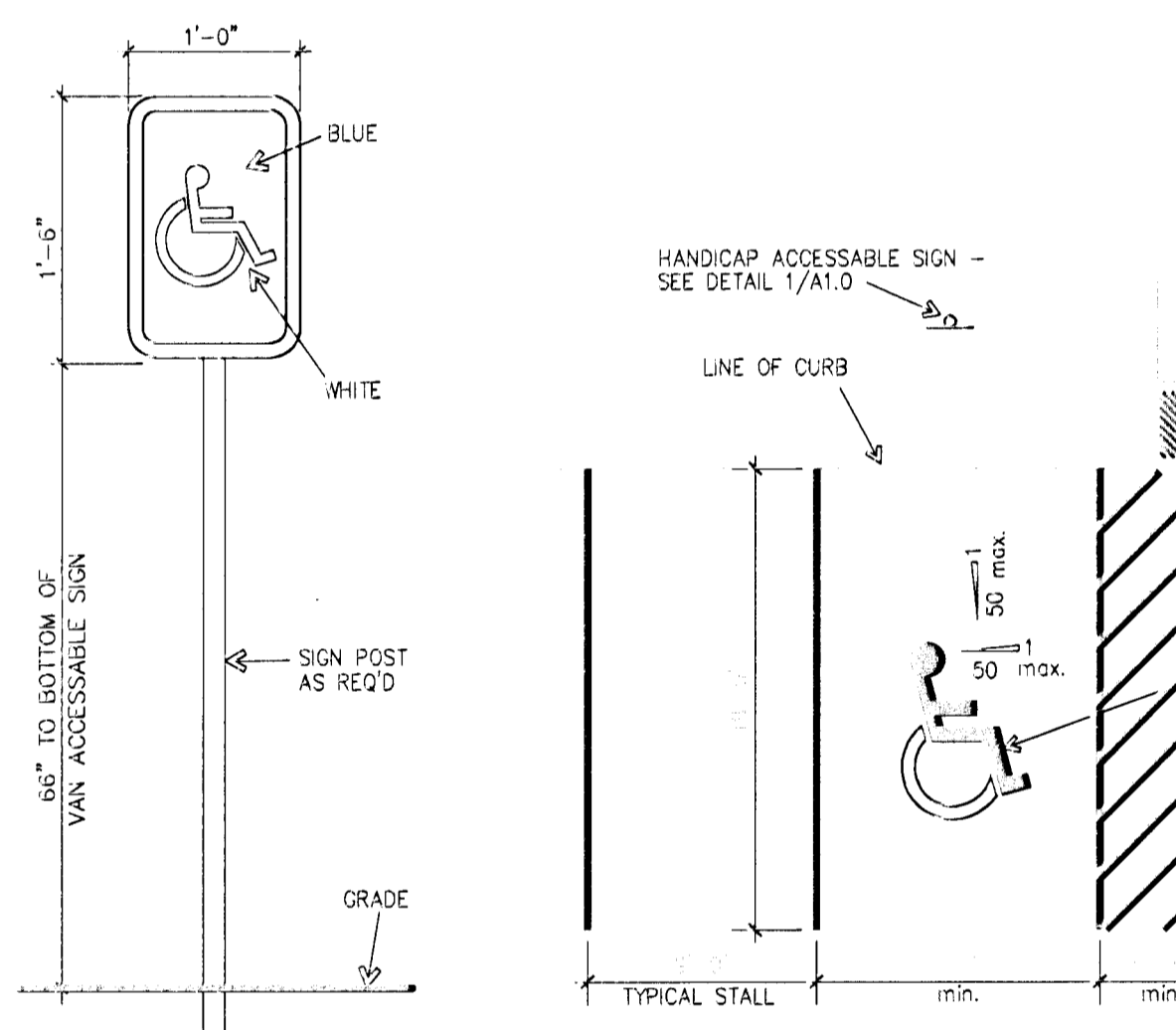

1 ADA SIGN DETAIL SCALE: NO SCALE
2 ADA PARKING STALL / RAMP SCALE: NO SCALE

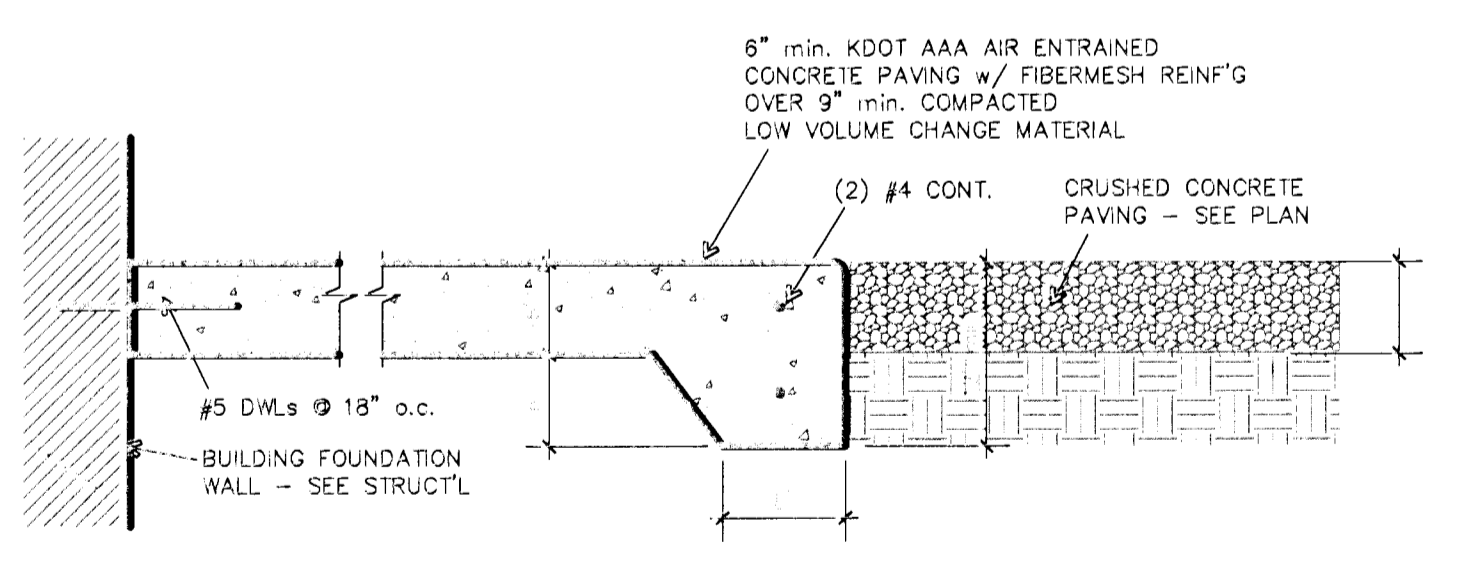

3 SITE PAVING DETAIL SCALE: NO SCALE

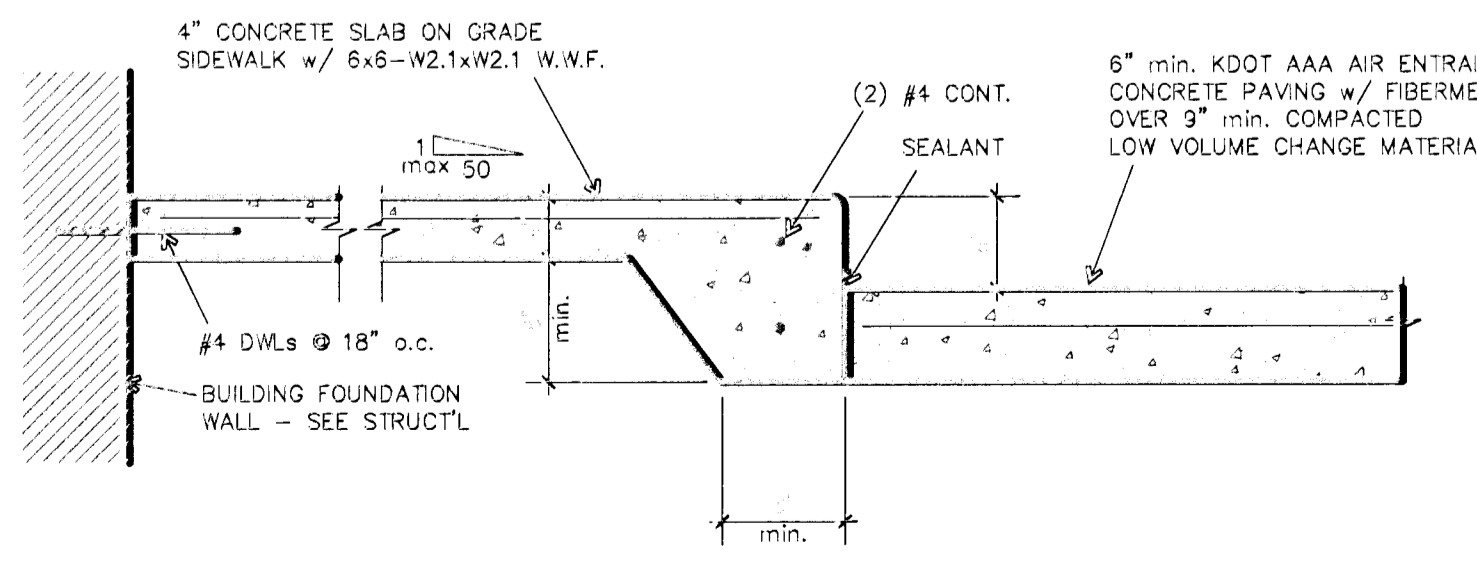

4 SITE PAVING DETAIL SCALE: NO SCALE

NOTE: A CITY OF WICHITA PRIVATE PROJECT IS REQUIRED FOR THE STORM SEWER INSTALLATION PROJECT.