

**APPROVED
DRAINAGE PLAN**

VICINITY MAP

MINIMUM PAD ELEVATIONS (LOWEST OPENINGS)				
ADD.	LOT	BLOCK	ELEVATION (CITY DATUM)	ELEVATION (USGS)
1ST	18	1	181.3	1368.7
1ST	19	1	184.0	1371.4
1ST	20	1	184.0	1371.4
1ST	21	1	184.8	1372.2
1ST	22	1	186.5	1373.9
1ST	23	1	186.5	1373.9
1ST	24	1	187.8	1375.2
1ST	25	1	188.1	1375.5
1ST	26	1	187.8	1375.2
1ST	27	1	186.5	1373.9
1ST	28	1	184.8	1372.2
1ST	29	1	184.0	1371.4
1ST	30	1	181.3	1368.7
1ST	31	1	181.3	1368.7
2ND	7	1	186.8	1374.2
2ND	8	1	186.8	1374.2
2ND	9	1	186.8	1374.2
2ND	10	1	186.8	1374.2
2ND	11	1	186.8	1374.2
2ND	12	1	186.8	1374.2
2ND	13	1	186.8	1374.2
2ND	14	1	186.8	1374.2
2ND	15	1	186.8	1374.2
2ND	16	1	186.8	1374.2
2ND	17	1	186.8	1374.2
2ND	18	1	186.8	1374.2
2ND	1	2	182.3	1369.7
2ND	2	2	182.3	1369.7
2ND	3	2	182.3	1369.7
2ND	4	2	182.3	1369.7
2ND	5	2	182.3	1369.7
2ND	6	2	182.3	1369.7

SW COR. NW 1/4 SEC.
15 127S, R2E, 6TH P.M.

SE COR. NW 1/4 SEC.
15 127S, R2E, 6TH P.M.

- RESERVES**
- A & B - PINE MEADOW 1ST OPEN SPACE, LANDSCAPING, MONUMENTS, IRRIGATION
 - A & B - PINE MEADOW 2ND DRAINAGE, LANDSCAPING, IRRIGATION, OPEN SPACE
 - C - PINE MEADOW 2ND BERMS, MONUMENTS, IRRIGATION, & LANDSCAPING
- NOTES**
- ZONING: EXISTING=SF-6 PROP.=SF-6
- BENCHMARK**
- BM#1 T POST 826.63' NORTH 1/4 COR. 1.45' WEST FENCE LINE. ELEV. = 1389.80

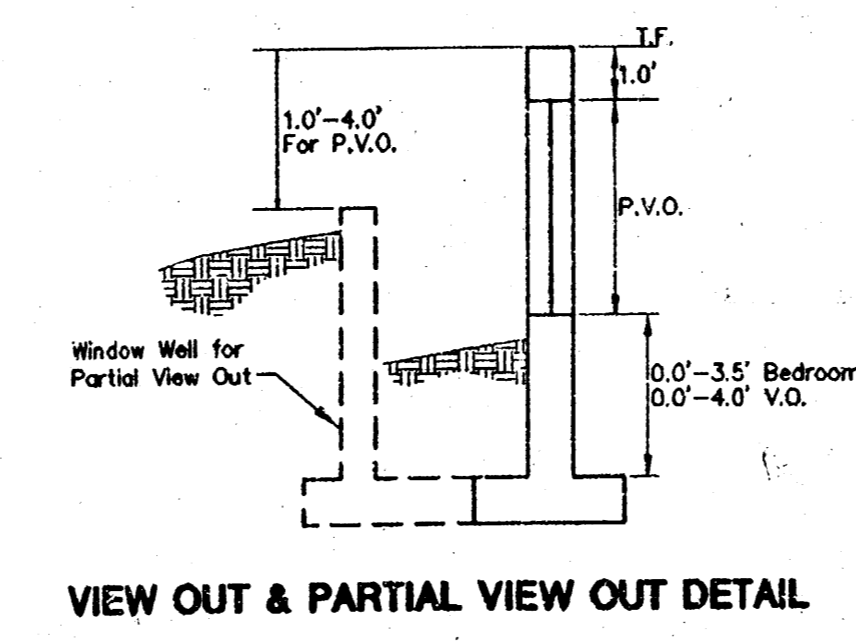
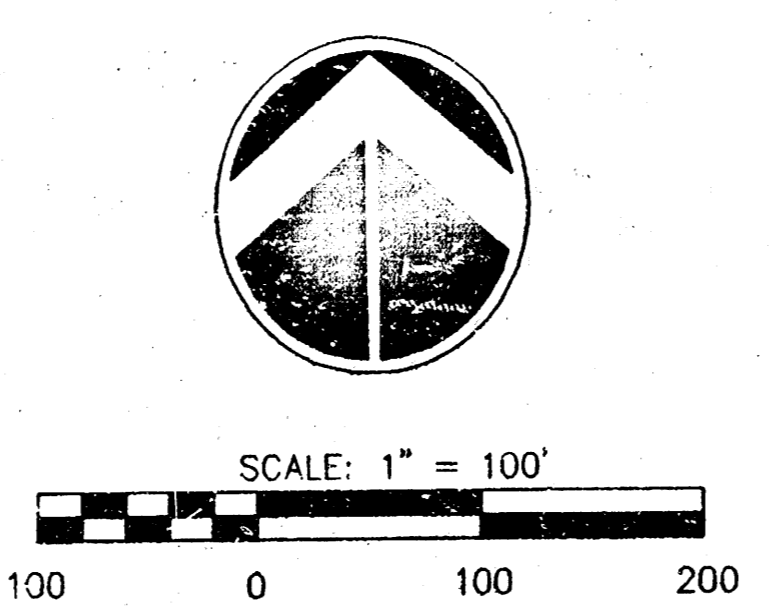

LEGEND

V.O. = VIEW OUT	1380.9 = PROPOSED GROUND ELEVATION
W.O. = WALK OUT	--- = PROP. SAN. SEWER
T.V.O. = TERRACED VIEW OUT	--- = EX. SAN. SEWER
P.V.O. = WALL HEIGHT GREATER THAN 42" VIEW OUT ON CORNER OF HOUSE	--- = EX. STORM WATER SEWER
	--- = PROP. STORM WATER SEWER
	--- = EX. WATER LINE
	--- = PROP. WATER LINE
	--- = FLOW ARROW

FINAL LOT GRADING PLAN PINE MEADOW ADDITION & PINE MEADOW 2ND ADDITION

DATE: MAY 2002

REVISED 02-27-03: LOTS 33&40, B.L.K. 1
REVISED 05-27-02: PAVYARD GRADING LOTS 30-35, B.L.K. 1
REVISED 05-25-02

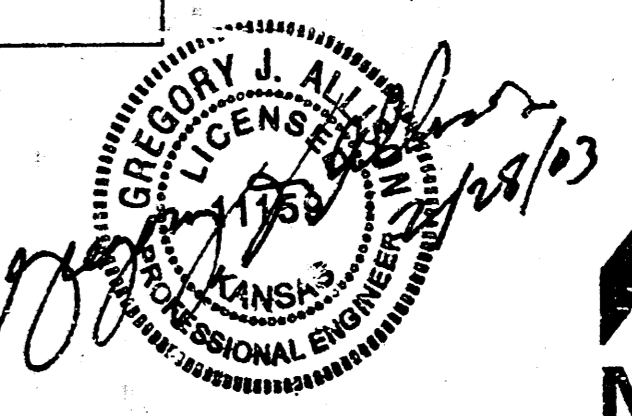

MKEC
ENGINEERING CONSULTANTS
411 N. WEBB ROAD
WICHITA, KS. 67206
316-684-9600

OWNERS/DEVELOPER: KISER GATEWAY, LLC & WILLARD J. KISER PROPERTIES, LLC.