

SCALE 1" = 100'

BENCH MARKS

BENCH MARK #1: USGS BRASS PLUG 28' S. & 530' W. OF CENTERLINE INTERSECTION OF CAPRI & PANNEE
ELEV.=1386.25 NGVD

BENCH MARK #2: CITY OF WICHITA STD. DISC 20.8' W & 54.5' S. OF CENTERLINE INTERSECTION DALTON & PANNEE
ELEV.=1379.60 NGVD

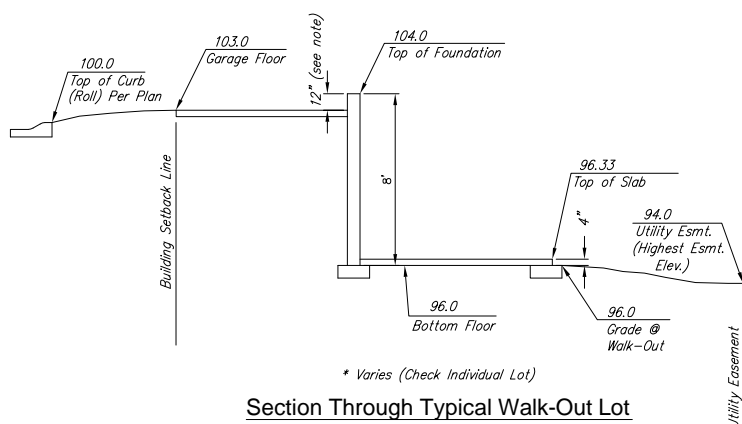

Section Through Typical Walk-Out Lot

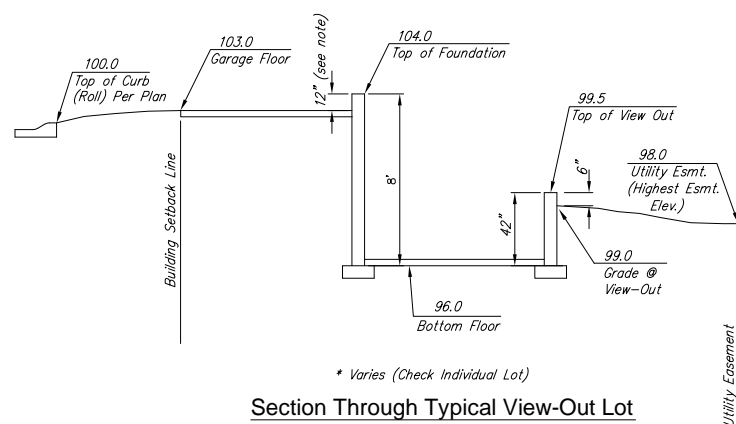

Section Through Typical View-Out Lot

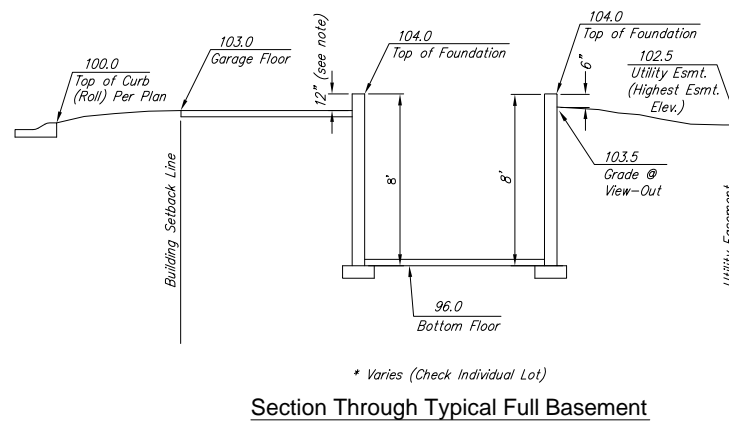

Section Through Typical Full Basement

NOTE: GRADES PROPOSED AT THE TIME OF HOME CONSTRUCTION MAY DIFFER FROM GRADES ON THIS PLAN. A DETAILED LOT GRADING PLAN STAMPED BY A PROFESSIONAL ENGINEER WILL BE REQUIRED FOR ANY LOT WHOSE PROPOSED GRADES DEVIATE FROM GRADES INDICATED HERE.

REVISED Feb. 5, 2002

**BRENTWOOD SOUTH ADDITION
GRADING PLAN
WICHITA, KANSAS**

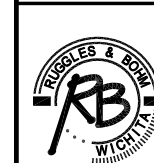

Ruggles & Bohm, P.A.
Engineering, Surveying, Land Planning

924 North Main (316) 264-8008
Wichita, Kansas 67203 (316) 264-4621 fax
www.rbkansas.com E-mail: info@rbkansas.com

DRAWING FILE: grading plan PROJECT NUMBER: DATE: June 8, 2001

DESIGN	KWL	SHEET	1
DRAWN	RA/KWL		
REVIEW		OF	1
UTILITY			