

Subdivision Grading Plan CHERYL'S HOLLOW 2ND ADDITION

Wichita, Sedgwick County, Kansas

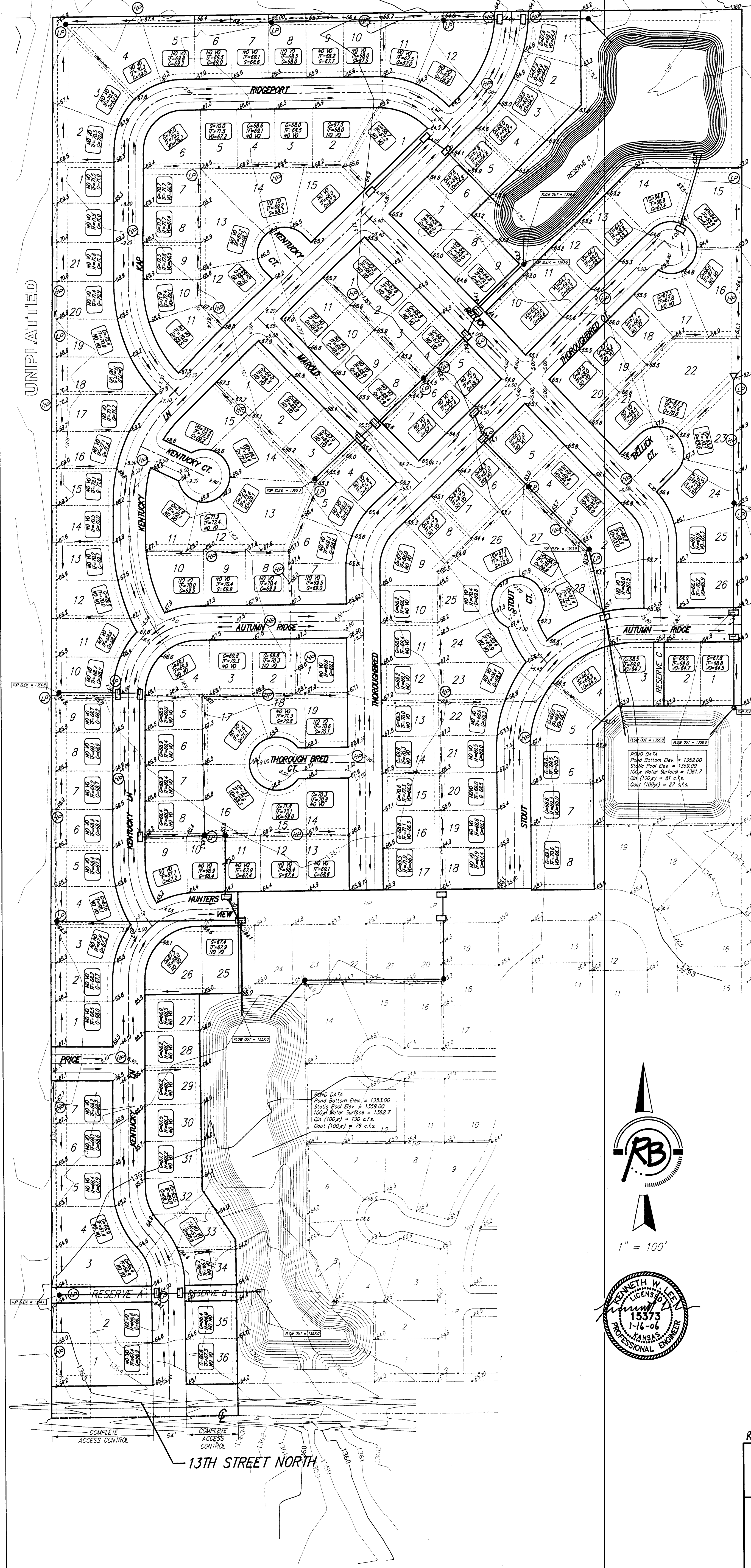

NORTH POND:
OUTLET STRUCTURE: 4.5' NOTCHED WEIR
0100 INFLOW (DEVELOPED) = 122 CFS
0100 OUTFLOW FROM POND = 62 CFS
100 YEAR WATER SURFACE = 1383.2
DISCHARGE TO SWALE FLOWING NORTH

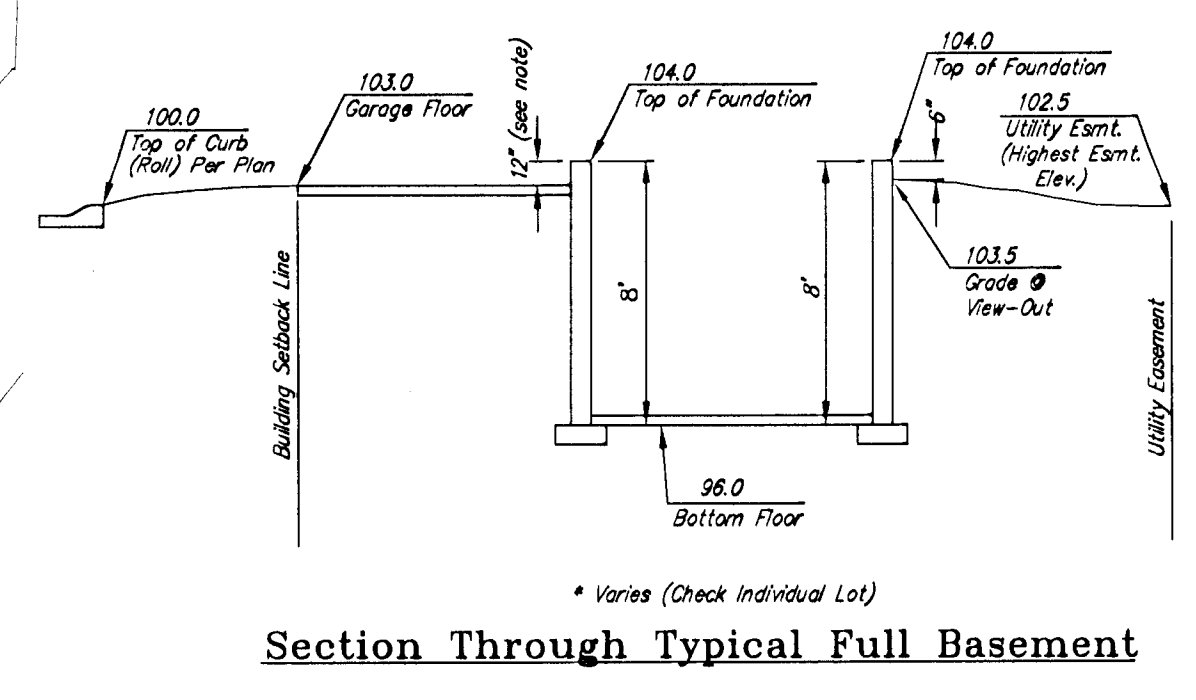
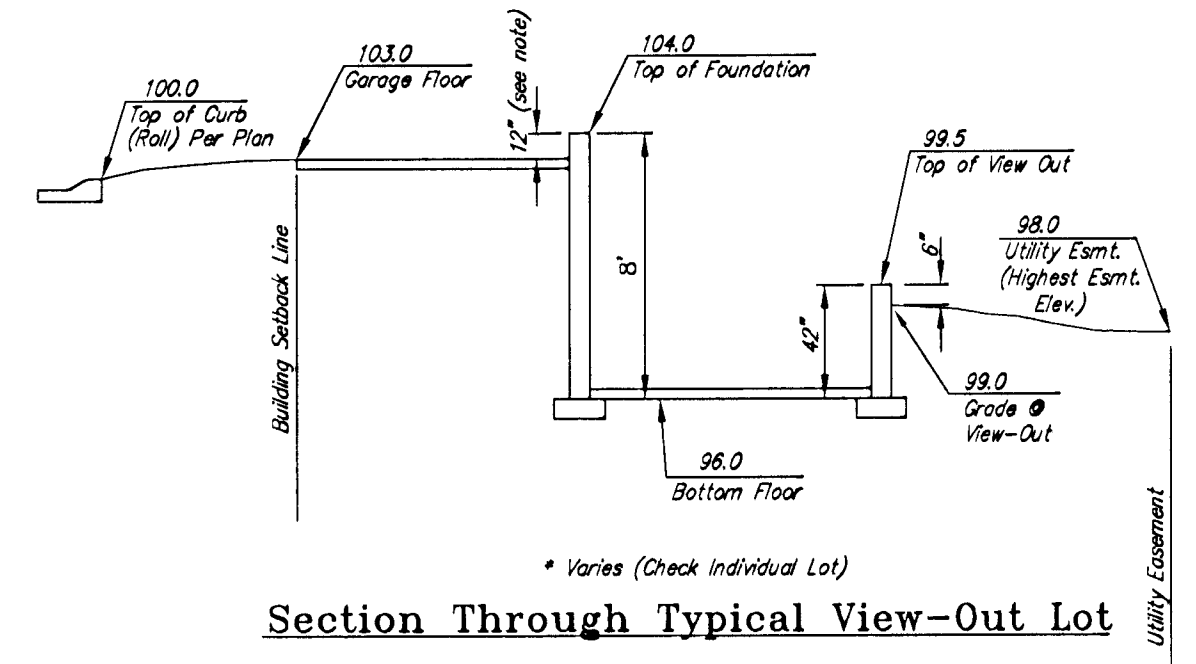
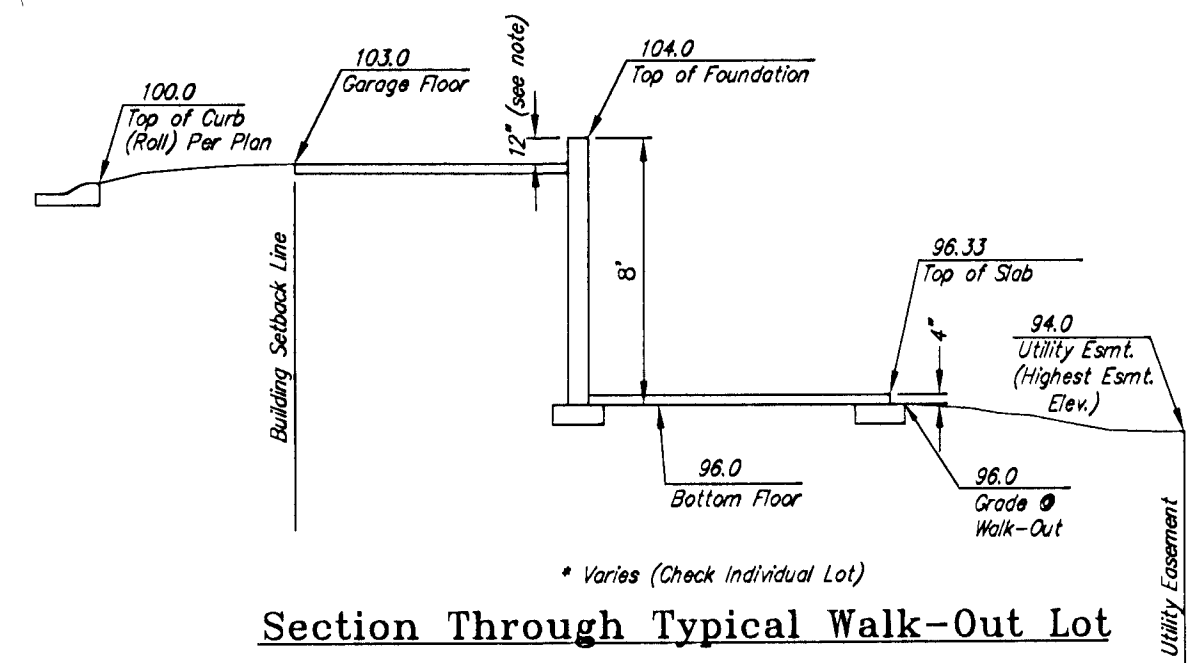

A 6" Berm will be required along the west property line to prevent water from exiting site.

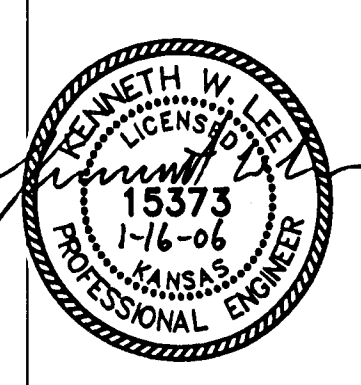
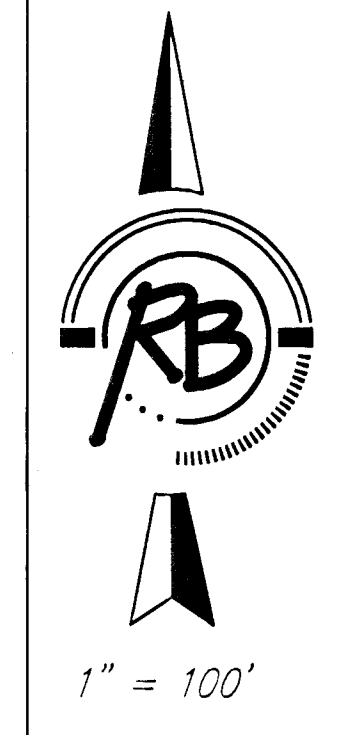

- LEGEND**
- XX.X Proposed Corner Grade
 - G=69.5 Proposed Viewout Elevation
 - TF=70.0 Proposed Garage Floor
 - VO=65.7 Proposed Top of Foundation

BENCH MARK: COW BENCHMARK AT THE SOUTHWEST CORNER OF INTERSECTION OF 135TH ST. W. AND 13TH ST. N., EAST SIDE OF CONC. BASE FOR HLP 30± S. OF CENTER LINE AND 35± W. OF CENTER LINE ELEV.=1355.65 (M.S.L.)

ON SITE BENCH MARK: R.R. SPIKE ON NORTH FACE OF HIGHLINE POWER POLE 131 FEET WEST AND 28 FEET SOUTH OF THE S.E. CORNER, W/2, SE1/4, SEC. 11, T27S, R2W ELEV.=1365.16 (M.S.L.)

NOTES: THE VO OPENINGS INDICATED ON THIS PLAN ARE THE LOWEST RECOMMENDED OPENING FOR THE LOTS. A STAMPED SITE PLAN SHOULD BE PREPARED IF LOWER GRADES ARE PROPOSED.

Revised 1-16-06

**CHERYL'S HOLLOW 2nd ADDITION
GRADING PLAN
WICHITA, KANSAS**

	Ruggles & Bohm, P.A. Engineering, Surveying, Land Planning	DESIGN KW/RLS	JOB NO. 2006
	924 North Main (316) 264-8008 Wichita, Kansas 67203(316) 264-4821 fax www.rbkansas.com E-mail: info@rbkansas.com	DRAWN RLS REVIEW CCH	
DRAWING FILE Phase 2 Grading Plan	PROJECT NUMBER Proj. No.	DATE Dec. 14, 2006	SHEET 1 OF 1