

Section Through Typical Full Basement

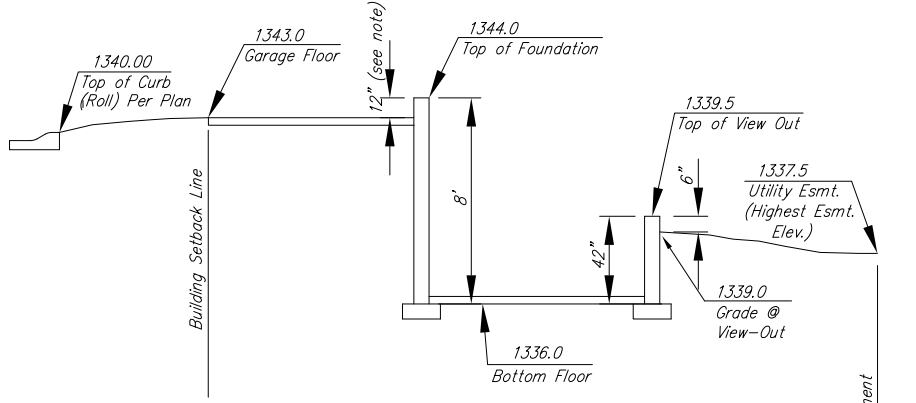

Section Through Typical View-Out Lot



BENCHMARK #1:
BRASS DISK AT THE WEST END OF WEST CURB
RETURN OF CHERRY CREEK AND CHERRY CREEK
COURT, IN FRONT OF LOT 3, BLOCK 1, SIERRA HILLS.
ELEVATION = 1350.84

* NOTE: DROP BRICK LEDGE, SIDING OR ADD RETAINING
WALL BETWEEN HOUSES TO MINIMIZE GRADE TRANSITIONS.

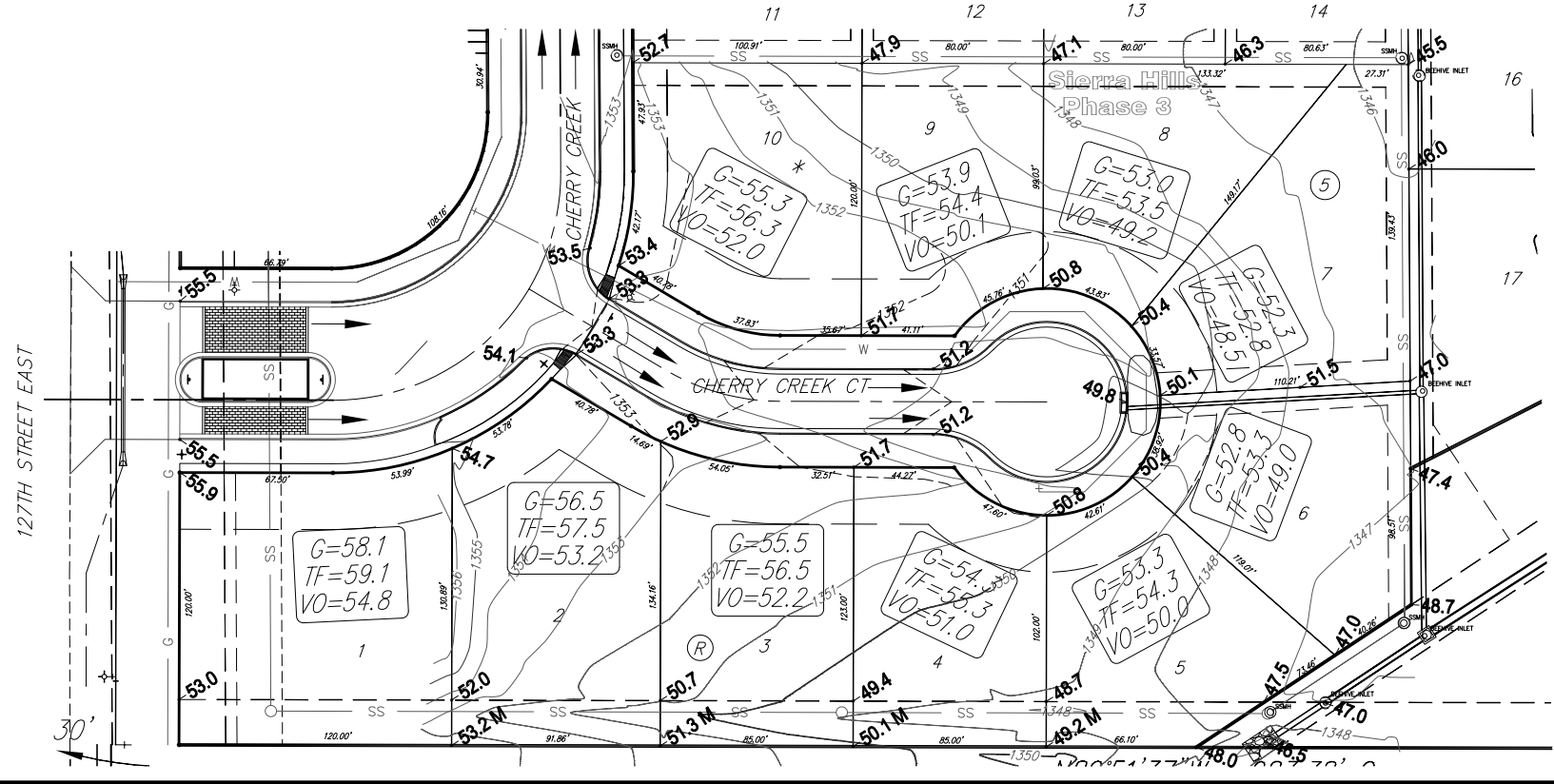

**SIERRA HILLS
Phase 3 Lot Grading Plan
WICHITA, KANSAS**

Ruggles & Bohm, P.A.
Engineering, Surveying, Land Planning

924 North Main
Wichita, Kansas 67203
www.rbkansas.com

(316) 264-8008
(316) 264-4621 fax
E-mail: info@rbkansas.com

DRAWING FILE SS [KEY MAP]	PROJECT NUMBER 472-84690	<table border="1" style="width: 100%; border-collapse: collapse;"> <tr> <td style="width: 15%;">DESIGN</td> <td style="width: 15%;">KWL</td> <td style="width: 15%;">DATE</td> <td style="width: 15%;">1</td> </tr> <tr> <td>DRAWN</td> <td>MLP</td> <td>DATE</td> <td>1</td> </tr> <tr> <td>REVIEW</td> <td></td> <td>DATE</td> <td>1</td> </tr> <tr> <td>UTILITY</td> <td></td> <td>DATE</td> <td>1</td> </tr> </table>	DESIGN	KWL	DATE	1	DRAWN	MLP	DATE	1	REVIEW		DATE	1	UTILITY		DATE	1
DESIGN	KWL	DATE	1															
DRAWN	MLP	DATE	1															
REVIEW		DATE	1															
UTILITY		DATE	1															