

# THE PINES AT SAWMILL CREEK

## Lot Grading Plan

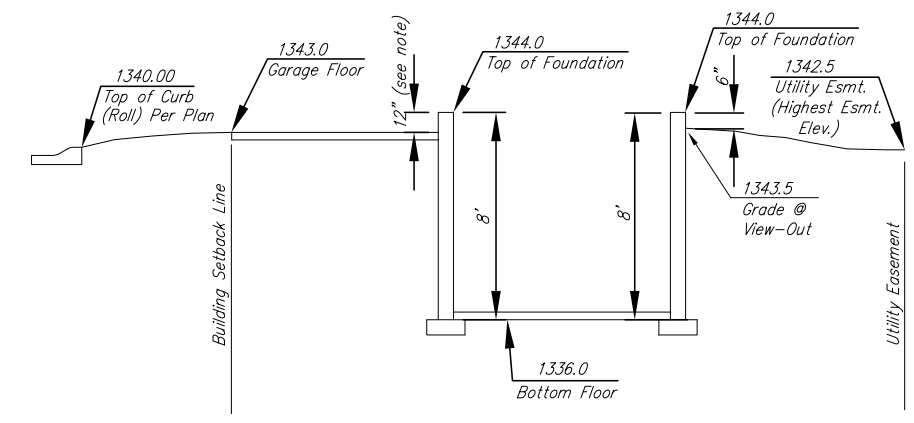

\* Varies (Check Individual Lot)  
Section Through Typical Full Basement

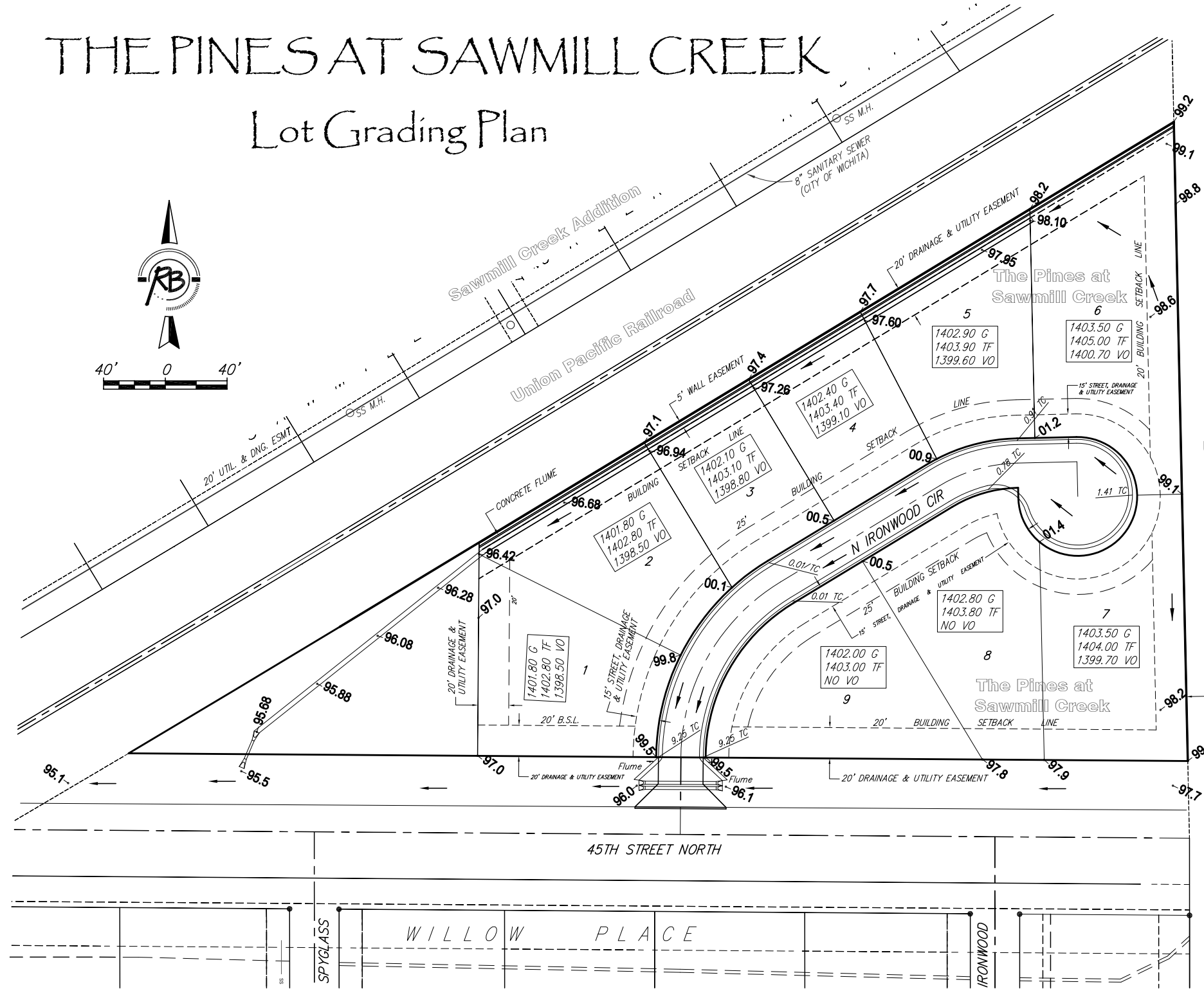
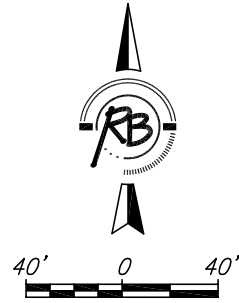
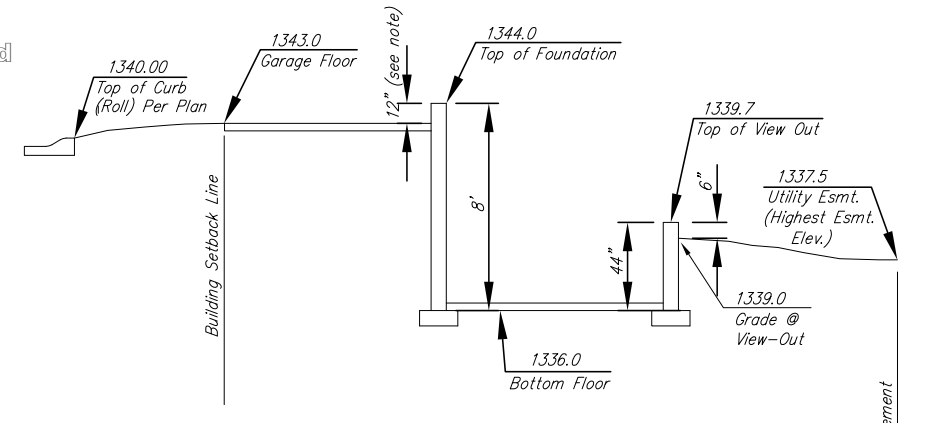

\* Varies (Check Individual Lot)  
Section Through Typical View-Out Lot

Unplatted



BENCHMARK: CHISELED SQUARE ON TOP OF THE CURB AT THE NORTH CURB RETURN AT THE NORTHEAST CORNER OF SPYGLASS & 44TH CIRCLE.  
ELEV. = 1397.64 (N.G.V.D. 1929)

BENCHMARK: CHISELED SQUARE ON TOP OF THE CURB AT THE N.W. CORNER OF LOT 2, BLOCK 4, SAWMILL CREEK ADDITION, SEDGWICK COUNTY, KANSAS.  
ELEV. = 1393.43 (N.G.V.D. 1929)

<b>THE PINES AT SAWMILL CREEK</b> <b>Lot Grading Plan</b> <b>WICHITA, KANSAS</b>			
	<b>Ruggles &amp; Bohm, P.A.</b> Engineering, Surveying, Land Planning		DESIGN AML
	924 North Main Wichita, Kansas 67203 www.rbkansas.com		(316) 264-8008 (316) 264-4621 fax E-mail: info@rbkansas.com
DRAWING FILE PAVING {4 CORNER GRADING}	PROJECT NUMBER 472-84630	DATE July 24, 2008	SHEET 1 OF 1