

BENCHMARK:
 CITY OF WICHITA DISC - SW CORNER OF THE INTERSECTION OF MAIZE ROAD AND PAINWEE, 44' S. OF E., 49.8' W. OF E., 12' E. OF FENCE, 85' SW OF SEC. COR.
 ELEV. = 135.12 CITY DATUM (1322.52 NGVD29)

CITY OF WICHITA DISC - N. OF THE FRONT LOT CORNER COMMON TO LOTS 29 AND 30, BLOCK D, SOUTHERN RIDGE ADDITION.
 N. OF FIRE HYDRANT ON TOP OF CURB.
 ELEV. = 146.71 CITY DATUM (1334.11 NGVD29)

CITY OF WICHITA DISC - SE. OF THE NE CORNER OF LOT 29, BLOCK D, SOUTHERN RIDGE ADDITION, E. OF FIRE HYDRANT ON TOP OF CURB.
 ELEV. = 146.73 CITY DATUM (1334.13 NGVD29)

CITY OF WICHITA DISC - SE. OF THE MOST SOUTHERLY CORNER OF LOT 13, BLOCK B, SOUTHERN RIDGE ADDITION.
 SE. OF FIRE HYDRANT ON TOP OF CURB.
 ELEV. = 144.10 CITY DATUM (1334.50 NGVD29)

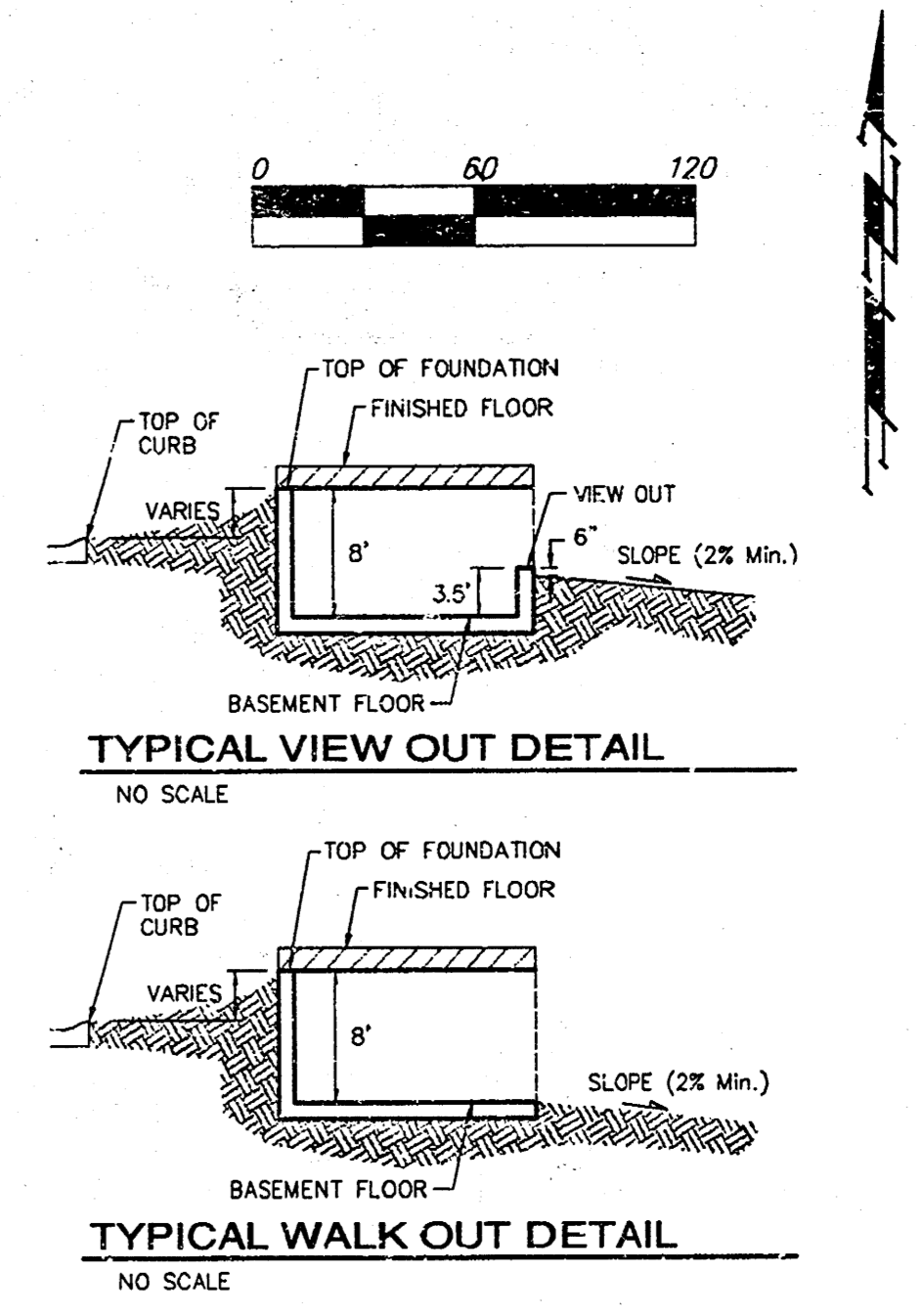
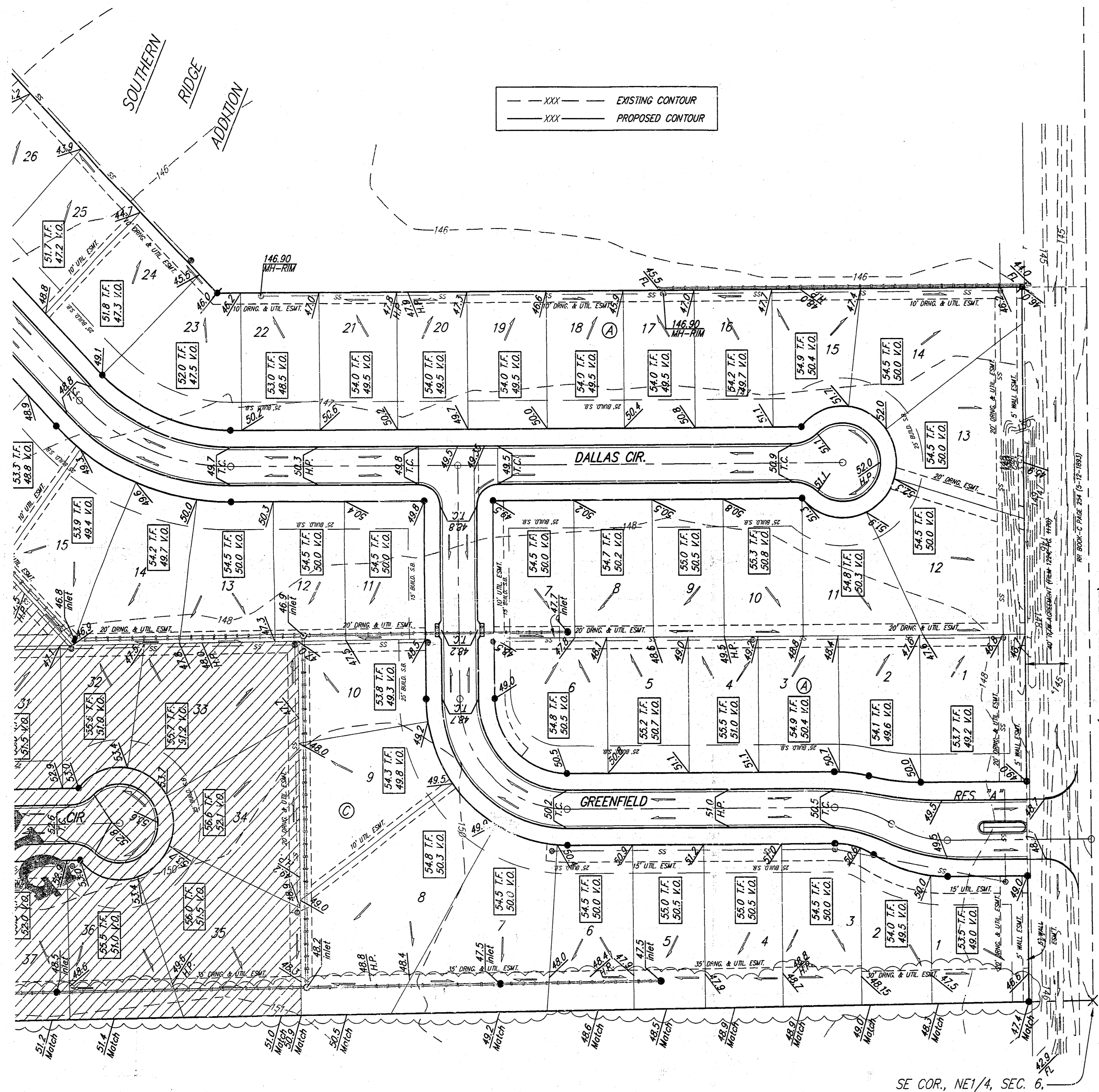

- NOTES:
1. PROPOSED TOP OF FOUNDATION ELEVATIONS ARE SHOWN ON PLANS. CONTRACTOR TO SET FINISHED FLOOR AND GARAGE FLOOR ELEVATIONS. ALL STREET ELEVATIONS SHOWN ON PLANS ARE FOR TOP OF CURB (FULL-HEIGHT).
 2. THIS GRADING PLAN IS DESIGNED WITH VIEW-OUTS AND WALK-OUTS. ELEVATIONS SHOWN AS XXX Y.O. DEPICT VIEW-OUT STRUCTURES. ELEVATIONS SHOWN AS XX.X Y.O. DEPICT WALK-OUT STRUCTURES.
 3. ALL LOTS SHALL MEET MINIMUM PAD REQUIREMENT AS SHOWN ON THE RECORDED PLAT.

MINIMUM BUILDING PAD ELEVATIONS FOR LOWEST OPENING TO THE STRUCTURES		
LOT	BLOCK	ELEVATION CITY DATUM
1-10	B	140.0

4. LOT DIMENSIONS HAVE BEEN OMITTED ON THIS PLAN. REFER TO THE RECORDED PLAT FOR FINAL DIMENSION, EASEMENT, & BUILDING SETBACK INFORMATION.
5. HOUSE PAD ELEVATIONS DEPICTED WITH BOLD OUTLINES AND NOTED WITH THIS SYMBOL INDICATE THAT DEEP FOOTINGS OR DEEP FOUNDATIONS MAY BE REQUIRED.
6. A DRAINAGE PLAN HAS BEEN DEVELOPED FOR THIS SUBDIVISION AND IS ON FILE WITH THE CITY OF WICHITA, KANSAS. DRAINAGE INTENT SHALL REMAIN AS DEPICTED OR AS MODIFIED WITH THE APPROVAL OF THE CITY ENGINEER OF THE CITY OF WICHITA, KANSAS. NO OBSTRUCTIONS WHICH IMPEDE THE FLOW OF THIS DRAINAGE PLAN SHALL BE ALLOWED.
7. ALL ELEVATIONS SHOWN ARE CITY OF WICHITA DATUM.
8. ALL LOTS WITHIN SOUTHERN RIDGE 3RD ADDITION SHALL HAVE A 5 FOOT INTERIOR SIDEYARD SETBACK.
9. BASEMENT SEWER SERVICE CAUTION! - CONTRACTOR SHALL VERIFY SEWER DEPTH PRIOR TO CONSTRUCTION AND SHALL TAKE NECESSARY MEASURES TO UPSIZE SERVICE OR INSTALL SERVICE LINE THROUGH FOOTING TO MAINTAIN BASEMENT SERVICE.

PRELIMINARY GRADING FOR FUTURE PHASES

APPROVED
DRAINAGE PLAN

SE COR., NE 1/4, SEC. 6,
 TWP. 28-S, R-1-W



REVISED TO FINAL 12/27/05 BY AEG

Baughman		SOUTHERN RIDGE 4TH ADDITION	
		SUBDIVISION GRADING PLAN	
		WICHITA, KANSAS	
Baughman Company, P.A. 315 8th St. W., Wm., KS 67211 P 316-262-7271 F 316-262-0149			
ENGINEERING SURVEYING PLANNING LANDSCAPE ARCHITECTURE			
PROJECT NUMBER	DESIGN	DRAWN	
	BLO/TRK	BLO/TRK	
REVISIONS	APPROVED	DATE	
		11/18/2004	
SCALE	noted		
SHEET			
			1 OF 2
F:\GRADE\SOUTHERN RIDGE 4TH\GRADE.DWG			

BENCHMARK
 CITY OF WICHITA DISC - SW CORNER OF THE INTERSECTION OF MAIZE ROAD AND PANHOLE.
 44° S. OF E.
 49.8' W. OF E.
 12' E. OF FENCE.
 65' SW. OF SEC. COR.
 ELEV. = 135.12 CITY DATUM
 (1322.52 NGVD29)

CITY OF WICHITA DISC - N. OF THE FRONT LOT CORNER COMMON TO LOTS 29 AND 30, BLOCK D, SOUTHERN RIDGE ADDITION.
 N. OF FIRE HYDRANT ON TOP OF CURB.
 ELEV. = 146.73 CITY DATUM
 (1334.11 NGVD29)

CITY OF WICHITA DISC - SE. OF THE NE. CORNER OF LOT 39, BLOCK D, SOUTHERN RIDGE ADDITION.
 E. OF FIRE HYDRANT ON TOP OF CURB.
 ELEV. = 146.73 CITY DATUM
 (1334.13 NGVD29)

CITY OF WICHITA DISC - SE. OF THE MOST SOUTHERLY CORNER OF LOT 13, BLOCK B, SOUTHERN RIDGE ADDITION.
 SE. OF FIRE HYDRANT ON TOP OF CURB.
 ELEV. = 144.10 CITY DATUM
 (1331.50 NGVD29)

--- XXX --- EXISTING CONTOUR
 --- XXX --- PROPOSED CONTOUR

APPROVED DRAINAGE PLAN
 KJ
 12/18/05

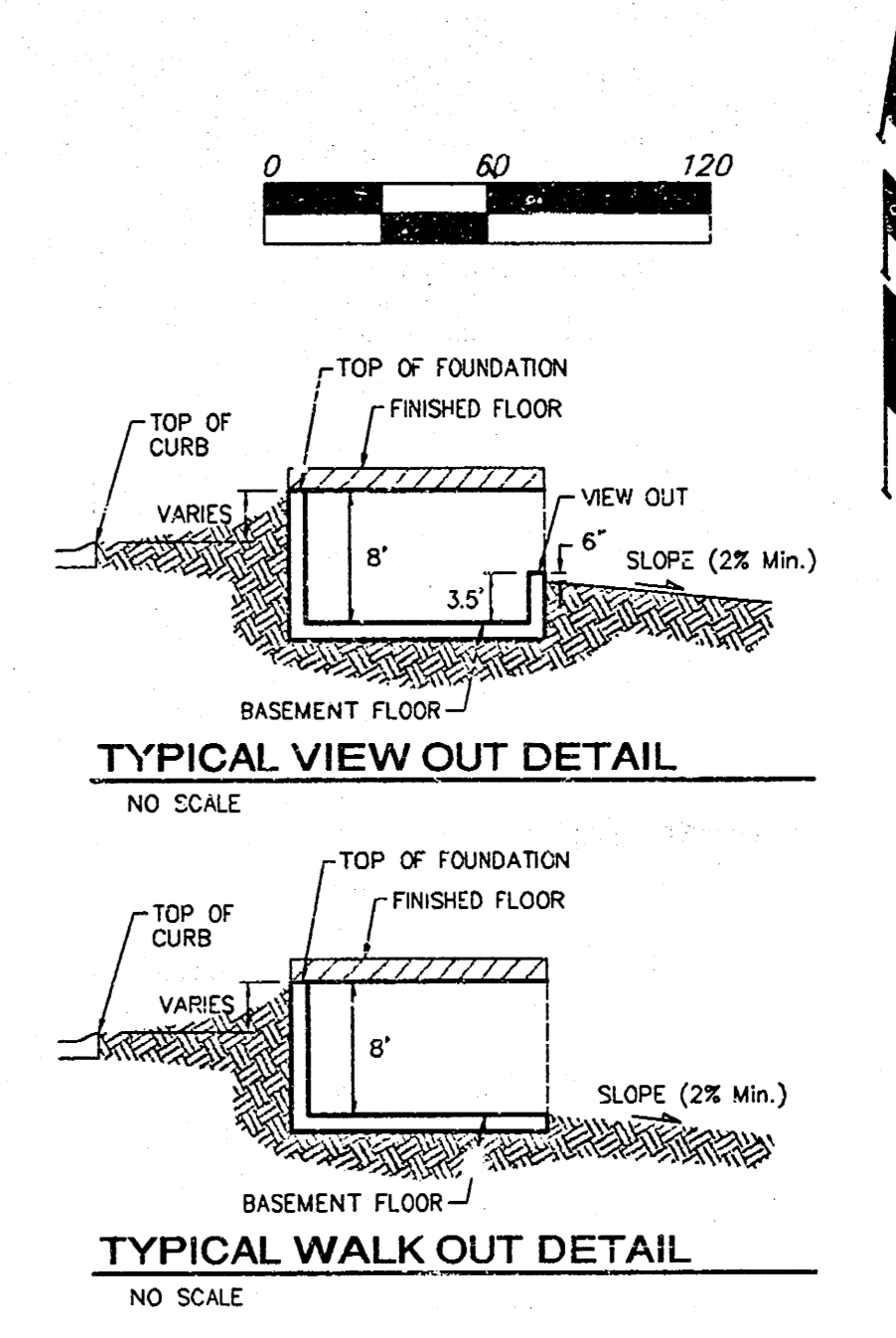
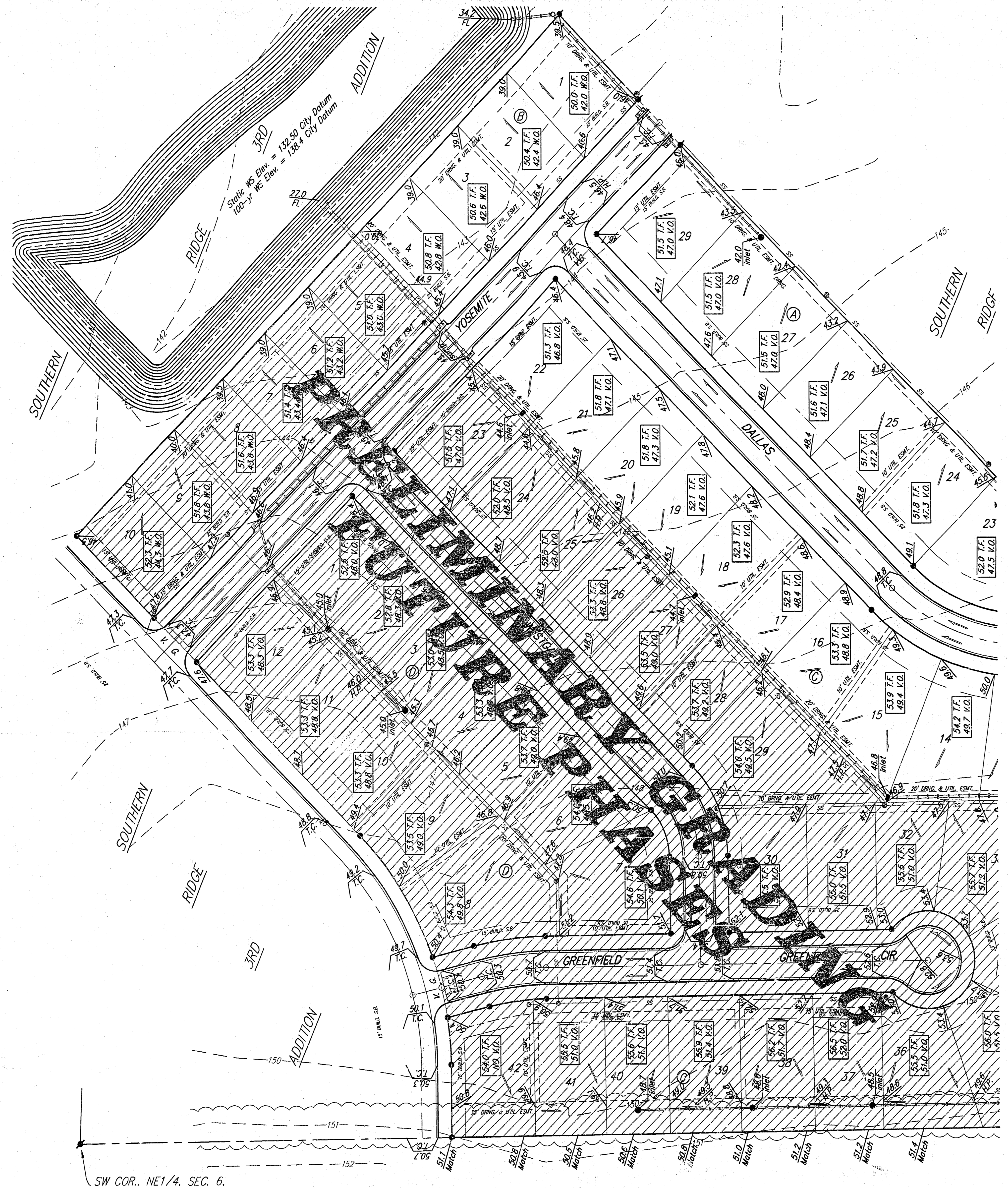

- NOTES:**
1. PROPOSED TOP OF FOUNDATION ELEVATIONS ARE SHOWN ON PLANS. CONTRACTOR TO SET FINISHED FLOOR AND GARAGE FLOOR ELEVATIONS. ALL STREET ELEVATIONS SHOWN ON PLANS ARE FOR TOP OF CURB (FULL-HEIGHT).
 2. THIS GRADING PLAN IS DESIGNED WITH VIEW-OUTS AND WALK-OUTS. ELEVATIONS SHOWN AS XX.Y V.O. DEPICT VIEW-OUT STRUCTURES. ELEVATIONS SHOWN AS XX.X W.O. DEPICT WALK-OUT STRUCTURES.
 3. ALL LOTS SHALL MEET MINIMUM PAD REQUIREMENT AS SHOWN ON THE RECORDED PLAT.

MINIMUM BUILDING PAD ELEVATIONS FOR LOWEST OPENING TO THE STRUCTURES		
LOT	BLOCK	ELEVATION CITY DATUM
1-10	B	140.0

4. LOT DIMENSIONS HAVE BEEN OMITTED ON THIS PLAN. REFER TO THE RECORDED PLAT FOR FINAL DIMENSION, EASEMENT, & BUILDING SETBACK INFORMATION.
 5. HOUSE PAD ELEVATIONS DEPICTED WITH BOLD OUTLINES AND NOTED WITH THIS SYMBOL INDICATE THAT DEEP FOOTINGS OR DEEP FOUNDATIONS MAY BE REQUIRED.
 6. A DRAINAGE PLAN HAS BEEN DEVELOPED FOR THIS SUBDIVISION AND IS ON FILE WITH THE CITY OF WICHITA, KANSAS. DRAINAGE INTENT SHALL REMAIN AS DEPICTED OR AS MODIFIED WITH THE APPROVAL OF THE CITY ENGINEER OF THE CITY OF WICHITA, KANSAS. NO OBSTRUCTIONS WHICH IMPEDE THE FLOW OF THIS DRAINAGE PLAN SHALL BE ALLOWED.
 7. ALL ELEVATIONS SHOWN ARE CITY OF WICHITA DATUM.
 8. ALL LOTS WITHIN SOUTHERN RIDGE 3RD ADDITION SHALL HAVE A 5 FOOT INTERIOR SIDEYARD SETBACK.
 9. **BASEMENT SEWER SERVICE CAUTION!** - CONTRACTOR SHALL VERIFY SEWER DEPTH PRIOR TO CONSTRUCTION AND SHALL TAKE NECESSARY MEASURES TO UPSIZE SERVICE OR INSTALL SERVICE LINE THROUGH FOOTING TO MAINTAIN BASEMENT SERVICE.
- PRELIMINARY GRADING FOR FUTURE PHASES

REVISED TO FINAL 12/27/05 BY AEG



Baughman		SOUTHERN RIDGE 4TH ADDITION SUBDIVISION GRADING PLAN WICHITA, KANSAS	
Baughman Company, P.A. 315 E. 10th St., Wichita, KS 67211 T 316-262-7771 F 316-262-0149 ENGINEERING SURVEYING PLANNING LANDSCAPE ARCHITECTURE			
PROJECT NUMBER	DESIGN	DRAWN	
	BLG/TRK	BLG/TRK	
REVISIONS:	APPROVED	DATE	
		11/18/2004	
	SCALE	noted	
	SHEET		
			2 OF 2
E:\GRADE\SOUTHERN RIDGE 4TH\GRADE.DWG			