

BELLECHASE

Subdivision Grading Plan

Wichita, Sedgwick County, Kansas

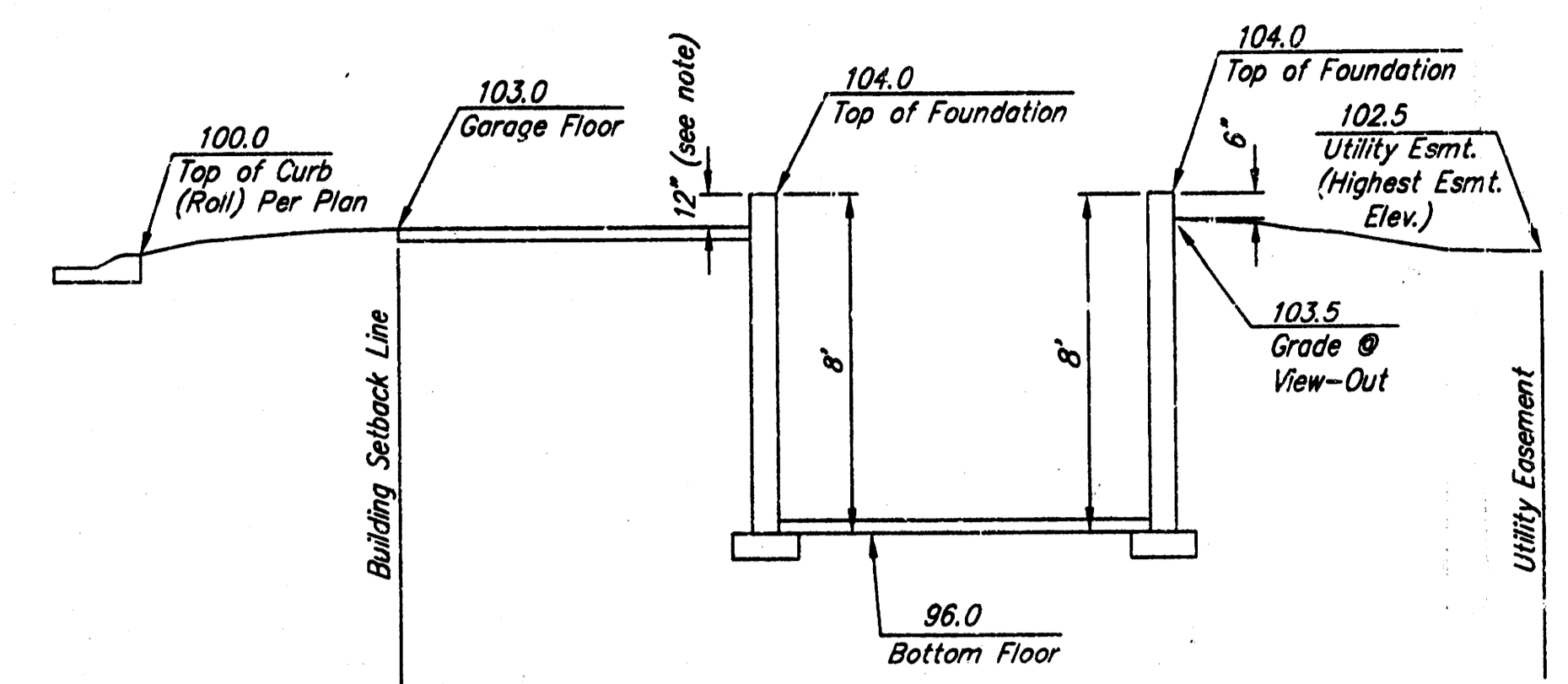
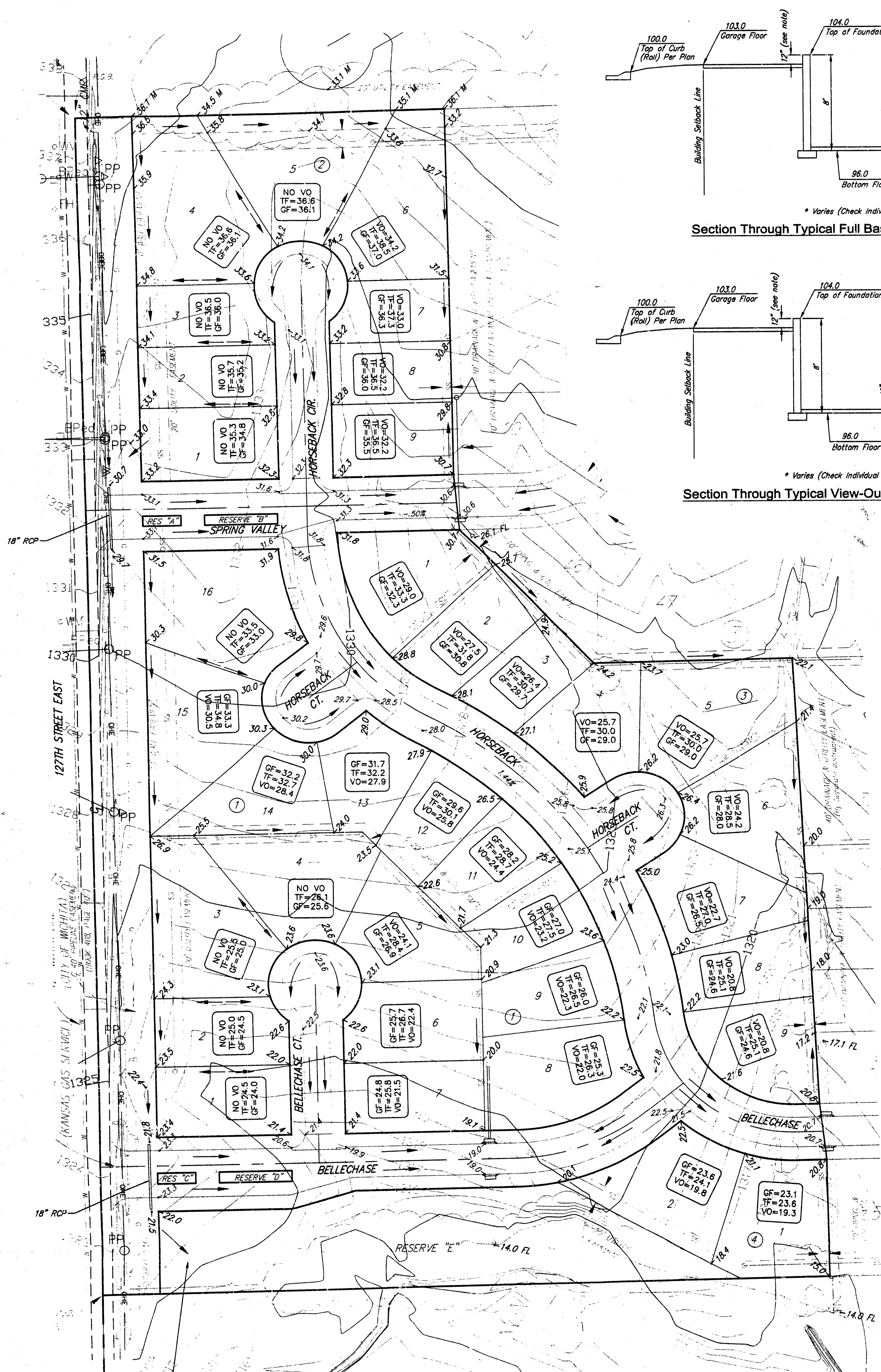

Section Through Typical Full Basement

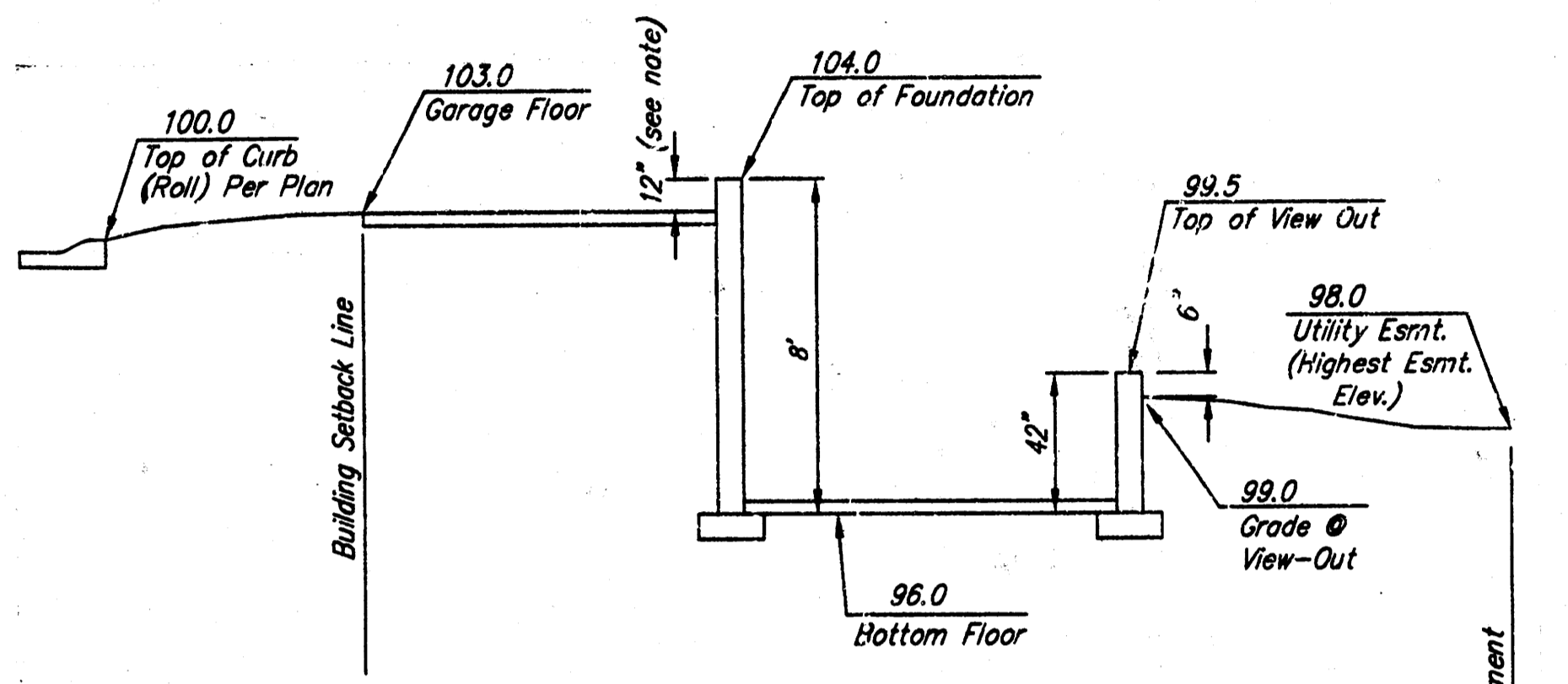

Section Through Typical View-Out Lot

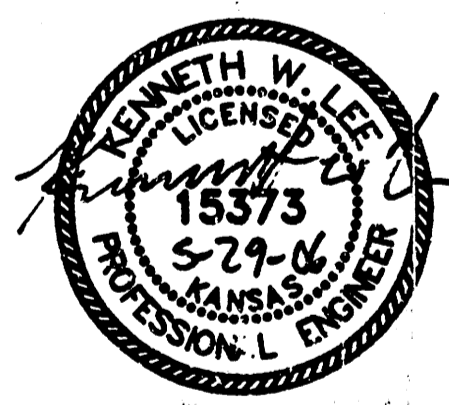

NOTE: GRADE DITCH TO DAYLIGHT IN AREA INDICATED. PROVIDE EROSION CONTROL MAT OR RIP-RAP AS NECESSARY TO PREVENT EROSION.

APPROVED DRAINAGE PLAN

BENCH MARK:
RAILROAD SPIKE IN SOUTH FACE OF POWER POLE 73' SOUTH SOUTHWEST OF THE WEST QUARTER CORNER OF SEC. 26, T27S, R2E ELEV.=1337.46 (NGVD)

LEGEND
 -XX-X Proposed Corner Grade
 G=69.5 Proposed Garage Floor
 TF=70.0 Proposed Top of Foundation
 VO=65.7 Proposed Viewout Elevation

REVISED May 29, 2006

BELLECHASE GRADING PLAN
WICHITA, KANSAS

Ruggles & Bohm, P.A.
Engineering, Surveying, Land Planning
924 North Main Wichita, Kansas 67203 (316) 264-8008 (316) 264-4621 fax
www.rbkansas.com E-mail: info@rbkansas.com

DESIGN	KWL	SHEET	1	
DRAWN	KWL			
REVIEW				
UTILITY				
DRAWING FILE	kenbose {layout}	PROJECT NUMBER	DATE	Mar. 28, 06