

BENCHMARK:
BRASS PLATE ON NORTH HUB GUARD
OF R.C.B.C. 50' EAST OF NW CORNER
NE 1/4, SEC. 22, TWP. 26-S., R-1-E.
ELEVATION = 1371.83 NGVD29

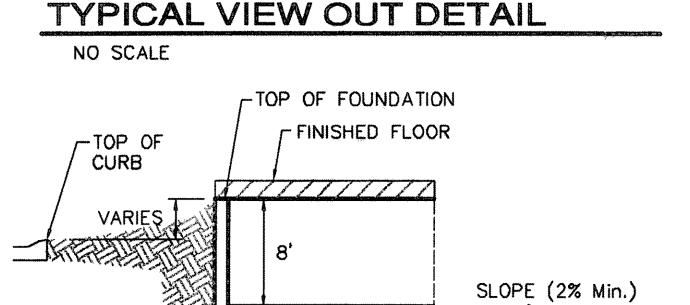
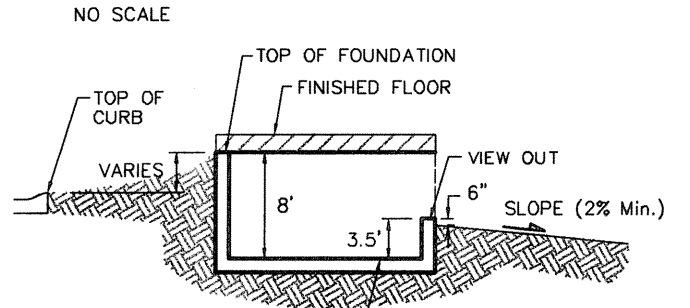
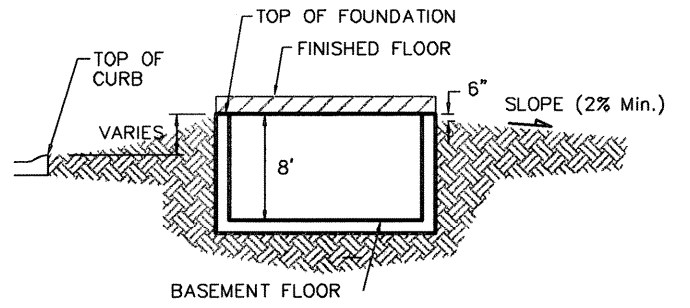

- NOTES:
1. PROPOSED TOP OF FOUNDATION ELEVATIONS ARE SHOWN ON PLANS. CONTRACTOR TO SET FINISHED FLOOR AND GARAGE FLOOR ELEVATIONS. ALL STREET ELEVATIONS SHOWN ON PLANS ARE FOR TOP OF CURB (FULL-HEIGHT).
 2. THIS GRADING PLAN IS DESIGNED WITH VIEW-OUTS AND WALK-OUTS. ELEVATIONS SHOWN AS XXX V.O. DEPICT VIEW-OUT STRUCTURES. ELEVATIONS SHOWN AS XXX W.O. DEPICT WALK-OUT STRUCTURES.
 3. ALL LOTS SHALL MEET MINIMUM PAD REQUIREMENT AS SHOWN ON THE RECORDED PLAT.

MINIMUM BUILDING PAD ELEVATIONS FOR LOWEST OPENING TO THE STRUCTURES		
LOT	BLOCK	ELEVATION NGVD29
1-9	A	1,353.0
10-12	A	1,354.0
13-19, 36, 37	A	1,355.0
46-50	A	1,355.0
51-55	A	1,357.0
21, 22	D	1,359.5

4. LOT DIMENSIONS HAVE BEEN OMITTED ON THIS PLAN. REFER TO THE RECORDED PLAT FOR FINAL DIMENSION, EASEMENT, & BUILDING SETBACK INFORMATION.
5. HOUSE PAD ELEVATIONS DEPICTED WITH BOLD OUTLINES AND NOTED WITH THIS SYMBOL INDICATE THAT DEEP FOOTINGS OR DEEP FOUNDATIONS MAY BE REQUIRED.
6. A DRAINAGE PLAN HAS BEEN DEVELOPED FOR THIS SUBDIVISION AND IS ON FILE WITH THE CITY OF WICHITA, KANSAS. DRAINAGE INTENT SHALL REMAIN AS DEPICTED OR AS MODIFIED WITH THE APPROVAL OF THE CITY ENGINEER OF THE CITY OF WICHITA, KANSAS. NO OBSTRUCTIONS WHICH IMPEDE THE FLOW OF THIS DRAINAGE PLAN SHALL BE ALLOWED.
7. ALL ELEVATIONS SHOWN ARE NATIONAL GEODETIC VERTICAL DATUM OF 1929 (NGVD29)

PRELIMINARY GRADING FOR FUTURE PHASES

Pond Data:
Static WS elev. = 1347.0
100-yr WS elev. = 1352.2

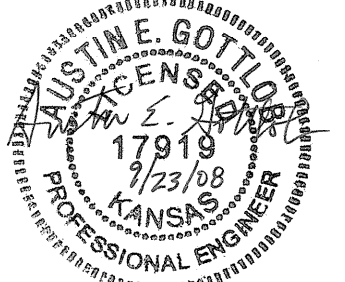

Baughman Company, P.A. 315 Ellis St. Wichita, KS 67211 P 316-262-2771 F 316-262-0149
ENGINEERING | SURVEYING | PLANNING | LANDSCAPE ARCHITECTURE

FALCON FALLS 2ND ADDITION
SUBDIVISION
GRADING PLAN
WICHITA, KANSAS

PROJECT NUMBER	DESIGN	DRAWN
425605	BLG	BLG
REVISIONS:	DATE	DATE
new lot opened	4/25/06	3-24-05
PH 1 REVISSED TO FINAL GRADES	AEG	
PH 2 REVISSED TO FINAL GRADES	AEG	
	SCALE	noted
	SHEET	

1 OF 2