

GRADING PLAN FALCON FALLS 3RD ADDITION WICHITA, SEDGWICK COUNTY, KANSAS

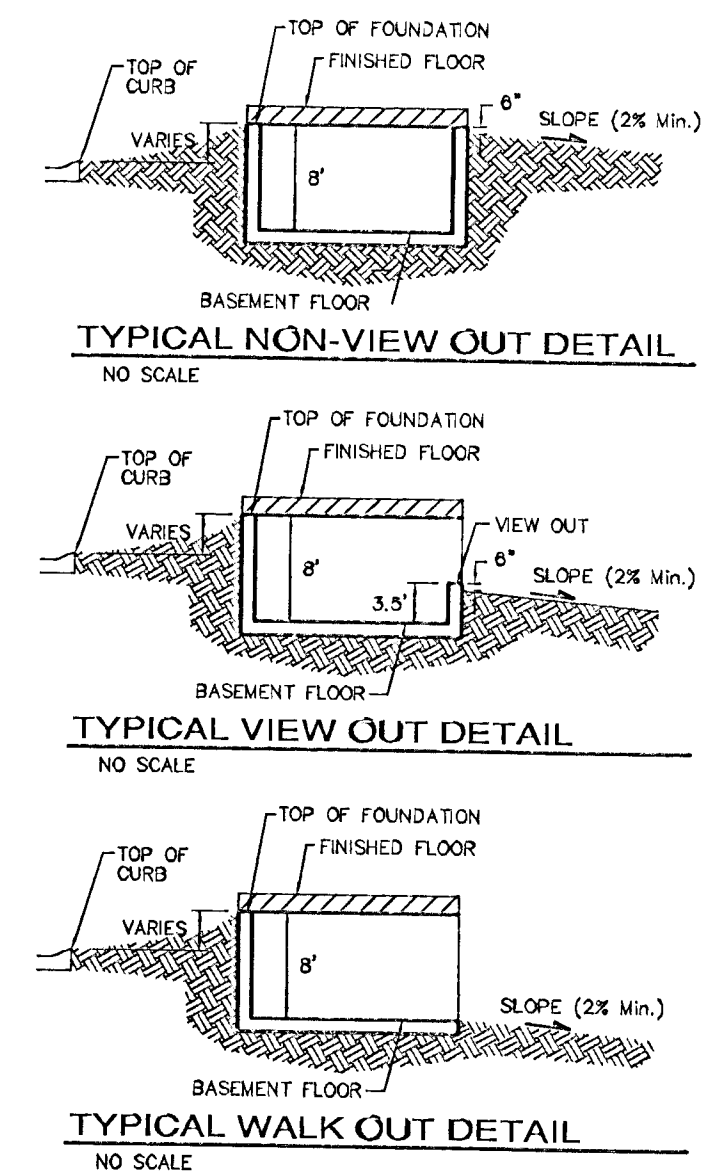
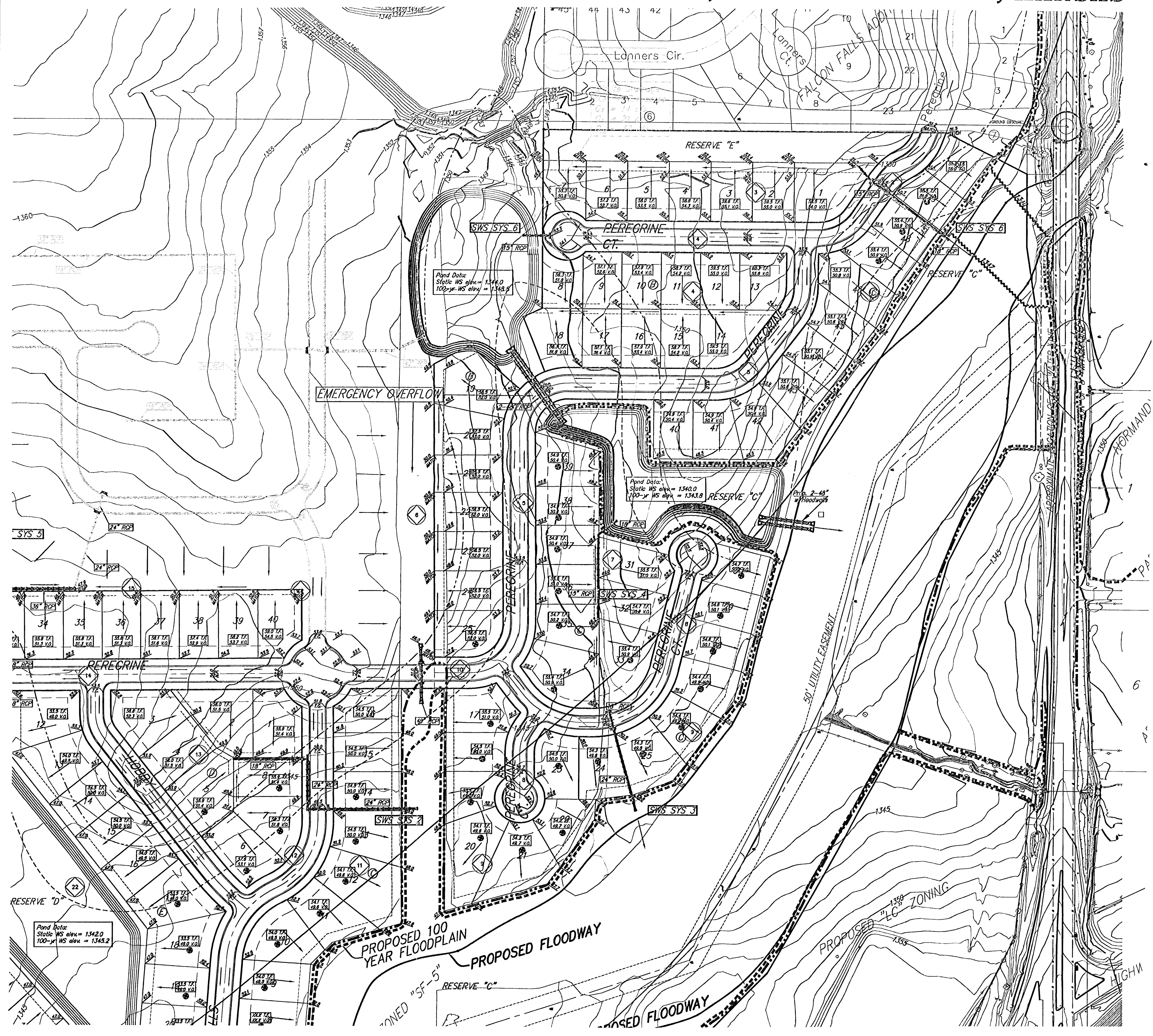

- NOTES:**
1. PROPOSED TOP OF FOUNDATION ELEVATIONS ARE SHOWN ON PLANS. CONTRACTOR TO SET FINISHED FLOOR AND GARAGE FLOOR ELEVATIONS. ALL STREET ELEVATIONS SHOWN ON PLANS ARE FOR TOP OF CURB (FULL-HEIGHT).
 2. THIS GRADING PLAN IS DESIGNED WITH VIEW-OUTS AND WALK-OUTS. ELEVATIONS SHOWN AS XXX V.O. DEPICT VIEW-OUT STRUCTURES. ELEVATIONS SHOWN AS XXXX W.O. DEPICT WALK-OUT STRUCTURES.
 3. ALL LOTS SHALL MEET MINIMUM PAD REQUIREMENT AS SHOWN ON THE RECORDED PLAT.

LOT	BLOCK	ELEVATION NGVD29
1-8, 13,14	A	1347.0
1-27	C	1348.0
28-31, 37-50	C	1349.0
7,8, 18-25	B	1353.0
1-22	E	1347.0

4. LOT DIMENSIONS HAVE BEEN OMITTED ON THIS PLAN. REFER TO THE RECORDED PLAT FOR FINAL DIMENSION, EASEMENT, & BUILDING SETBACK INFORMATION.
5. HOUSE PAD ELEVATIONS DEPICTED WITH BOLD OUTLINES AND NOTED WITH THIS SYMBOL INDICATE THAT DEEP FOOTINGS OR DEEP FOUNDATIONS MAY BE REQUIRED.
6. A DRAINAGE PLAN HAS BEEN DEVELOPED FOR THIS SUBDIVISION AND IS ON FILE WITH THE CITY OF WICHITA, KANSAS. DRAINAGE INTENT SHALL REMAIN AS DEPICTED OR AS MODIFIED WITH THE APPROVAL OF THE CITY ENGINEER OF THE CITY OF WICHITA, KANSAS. NO OBSTRUCTIONS WHICH IMPEDE THE FLOW OF THIS DRAINAGE PLAN SHALL BE ALLOWED.
7. NO BUILDING PERMITS ARE TO BE ISSUED FOR ANY LOTS THAT ARE LOCATED IN THE SPECIAL FLOOD HAZARD AREA WITHIN THIS PLATTED SUBDIVISION UNLESS ONE OF THE FOLLOWING CONDITIONS ARE MET.
 - A. THE LOWEST FLOOR (INCLUDING BASEMENT) IS CONSTRUCTED A MINIMUM OF 1 FOOT ABOVE THE DETERMINED BASE FLOOD ELEVATION.
 - OR
 - B. A LETTER OF MAP REVISION (LOMR) IS ISSUED BY THE FEDERAL EMERGENCY MANAGEMENT AGENCY (FEMA) REMOVING THE SUBJECT PROPERTY FROM THE SPECIAL FLOOD HAZARD AREA, WHICH WOULD THEN ALLOW BUILDINGS TO BE CONSTRUCTED WITH THE LOWEST OPENING AS SPECIFIED ON THIS GRADING PLAN AND MEETING FEMA TECHNICAL BULLETIN 10-01.

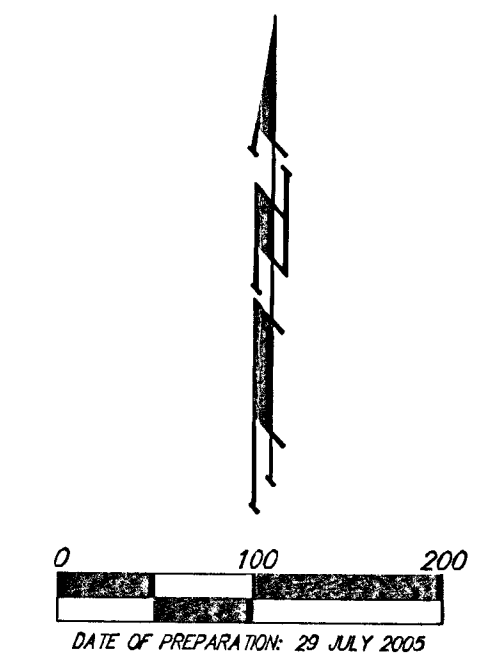

BENCHMARK:
* CUT ON E. HUBBARD OF R.C.B.C.,
110' S. OF THE SE COR., SE 1/4, SEC. 22,
TWP. 26-S, R-1-E.
ELEV. = 1359.54 NGVD29

NOTE: SWS System #5 and north-east pond system proposed in Falcon Falls 2nd Addition.

NOTE:
NO BUILDING PERMITS ARE TO BE ISSUED FOR LOTS 5-9, 13, 14, BLOCK A, OR 9, 16-28, BLOCK B, 17, 31, 35-39, 43-49, BLOCK C, 6-9, BLOCK D, 2-11, 16-18, BLOCK E, WITHIN FALCON FALLS 3RD ADDITION UNLESS THE LOWEST FLOOR CAN BE CONSTRUCTED AT OR ABOVE THE BASE FLOOD ELEVATION OR UNLESS THE CITY OF WICHITA, KANSAS HAS RECEIVED A LETTER OF MAP REVISION FROM THE FEDERAL EMERGENCY MANAGEMENT AGENCY.

NOTE:
NO BUILDING PERMITS ARE TO BE ISSUED FOR LOTS 1-4, 10-12, BLOCK A, 1-13, 18-20, 32-34, BLOCK C, 1, 19-22, BLOCK E, WITHIN FALCON FALLS 3RD ADDITION UNLESS THE CITY OF WICHITA, KANSAS HAS RECEIVED A LETTER OF MAP REVISION FROM THE FEDERAL EMERGENCY MANAGEMENT AGENCY.