

DESIGN

AIDS

(Joins sheet 28)

36

N

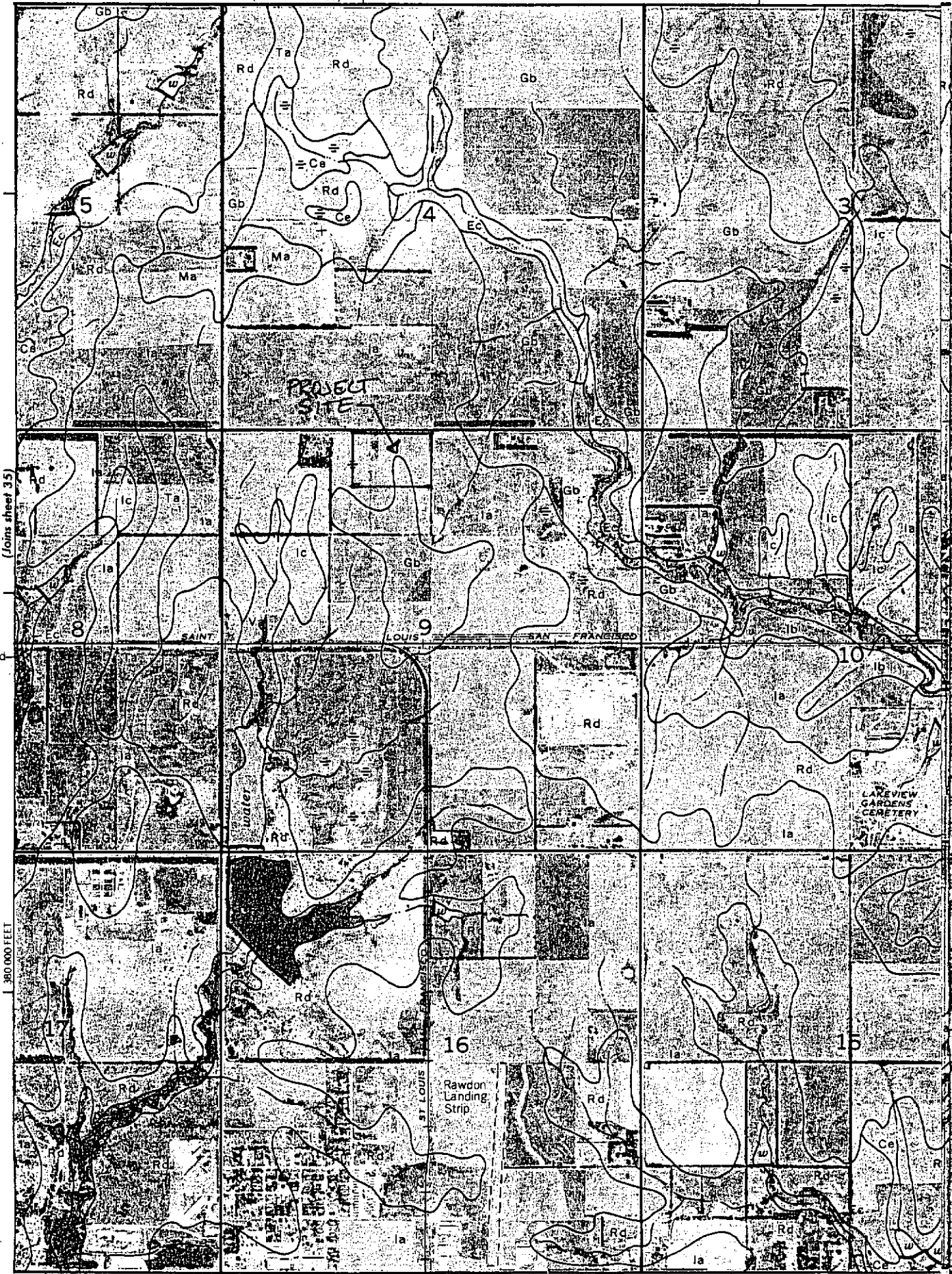

(Joins sheet 44) 2 370 000 FEET

SOIL LEGEND

SYMBOL	NAME
Aa	Albion-Shellabarger sandy loams, 1 to 4 percent slopes
Ab	Albion and Shellabarger sandy loams, 7 to 15 percent slopes
Ba	Blanket silt loam, 0 to 1 percent slopes
Bb	Blanket silt loam, 1 to 3 percent slopes
Ca	Canadian fine sandy loam
Cb	Canadian-Waldeck fine sandy loams
Cc	Garwile fine sandy loam
Cd	Clark-Ost clay loams, 1 to 4 percent slopes
Ce	Clime silty clay, 3 to 6 percent slopes
Ea	Elandco silt loam
Eb	Elandco silt loam, occasionally flooded
Ec	Elandco silt loam, frequently flooded
Fa	Farnum loam, 0 to 1 percent slopes
Fb	Farnum loam, 1 to 3 percent slopes
Fc	Farnum loam, sandy substratum, 0 to 1 percent slopes
Ga	Goesseil silty clay, 0 to 1 percent slopes
Gb	Goesseil silty clay, 1 to 2 percent slopes
Ia	Irwin silty clay loam, 1 to 3 percent slopes
Ib	Irwin silty clay loam, 3 to 6 percent slopes
Ic	Irwin silty clay loam, 2 to 6 percent slopes, eroded
La	Lesho loam
Lb	Lincoln soils
Ma	Milan loam, 1 to 3 percent slopes
Mb	Milan loam, 3 to 6 percent slopes
Mc	Milan clay loam, 2 to 6 percent slopes, eroded
Na	Naron fine sandy loam
Oc	Owens clay loam, 1 to 3 percent slopes
Od	Owens-Rock outcrop complex, 3 to 10 percent slopes
Pa	Pits
Pb	Plevna fine sandy loam
Pc	Pratt loamy fine sand, undulating
Pd	Pratt-Tivoli complex, rolling
Ra	Renfrow silty clay loam, 1 to 3 percent slopes
Rb	Renfrow silty clay loam, 3 to 6 percent slopes
Rc	Renfrow-Owens clay loams, 1 to 4 percent slopes
Rd	Rosehill silty clay, 1 to 3 percent slopes
Sa	Shellabarger sandy loam, 1 to 3 percent slopes
Sb	Shellabarger sandy loam, 3 to 6 percent slopes
Sc	Shellabarger sandy loam, 3 to 6 percent slopes, eroded
Ta	Tabler silty clay loam
Tb	Tabler-Drummond complex
Us	Urban land-Canadian complex
Ub	Urban land-Elandco complex
Uc	Urban land-Farnum complex, 0 to 3 percent slopes
Ud	Urban land-Irwin complex, 1 to 3 percent slopes
Ue	Urban land-Tabler complex
Va	Vanoss silt loam, 0 to 1 percent slopes
Vb	Vanoss silt loam, 1 to 3 percent slopes
Vc	Vanoss silt loam, 3 to 6 percent slopes
Vd	Vanoss silt loam, 3 to 6 percent slopes, eroded
Ve	Vernon sandy loam, 1 to 3 percent slopes
Vf	Vernon sandy loam, 3 to 6 percent slopes
Wa	Waldeck sandy loam
Wb	Waurika silt loam

KS-2-5

County	Expected 24-hour Storm Rainfall in Inches						Normal Annual Precipitation Inches
	Storm Frequency in Years						
	100	50	25	10	5	2	
Pawnee	6.6	6.0	5.2	4.5	3.7	2.8	23.3
Phillips	6.0	5.5	4.8	4.1	3.4	2.5	23.6
Pottawatomie	7.5	6.6	5.9	5.1	4.3	3.4	33.6
Pratt	7.2	6.4	5.6	4.8	4.1	3.0	24.6
Rawlins	5.5	5.0	4.3	3.6	3.1	2.3	21.0
Reno	7.4	6.6	5.8	5.0	4.2	3.2	27.7
Republic	6.8	6.0	5.4	4.6	3.9	2.9	28.6
Rice	7.3	6.4	5.6	4.8	4.1	3.0	26.6
Riley	7.4	6.5	5.8	5.1	4.3	3.3	33.5
Rooks	6.1	5.7	4.9	4.1	3.4	2.5	23.9
Rush	6.5	5.9	5.0	4.3	3.6	2.7	23.3
Russell	6.7	5.9	5.2	4.4	3.7	2.8	26.8
Saline	7.3	6.4	5.7	4.9	4.1	3.1	28.4
Scott	5.7	5.3	4.5	3.8	3.2	2.4	20.2
Sedgwick	7.8	7.0	6.1	5.3	4.5	3.5	30.6
Seward	6.0	5.7	4.8	4.2	3.5	2.6	19.8
Shawnee	7.8	6.8	6.1	5.3	4.5	3.5	34.7
Sheridan	5.7	5.3	4.5	3.8	3.2	2.4	21.3
Sherman	5.3	4.8	4.2	3.5	3.0	2.2	16.7
Smith	6.3	5.7	5.0	4.2	3.5	2.6	24.4
Stafford	7.1	6.2	5.5	4.7	4.0	2.9	25.1
Stanton	5.6	5.2	4.5	3.8	3.2	2.4	15.8
Stevens	5.9	5.5	4.7	4.1	3.4	2.5	19.7
Sumner	8.0	7.1	6.2	5.4	4.6	3.6	34.0

## ATTACHMENT D

## DRAINAGE CRITERIA

## CITY OF WICHITA, KANSAS

RECOMMENDED RUNOFF COEFFICIENTS FOR RATIONAL METHOD  
AND PERCENT IMPERVIOUS FOR UNIT HYDROGRAPH METHOD

Land Use or Surface Characteristics	Percent Impervious	Frequency			
		<u>2</u>	<u>5</u>	<u>10</u>	<u>100</u>
1. Business:					
Downtown Areas	95	0.84	0.85	0.87	0.91
Neighborhood Areas	70	0.68	0.69	0.73	0.80
2. Residential:					
Single Family (Soil Group D)					
1/8 Acre	50	0.57	0.61	0.66	0.79
1/4 Acre	38	0.50	0.54	0.62	0.76
1/3 Acre	30	0.46	0.50	0.59	0.73
1/2 Acre	25	0.42	0.48	0.56	0.72
3/4 Acre	22	0.42	0.46	0.55	0.71
1 Acre	20	0.41	0.45	0.54	0.71
Multi-Family (Soil Group D)					
Multi-Unit (detached)	60	0.62	0.66	0.72	0.82
Multi-Unit (attached)	65	0.64	0.68	0.73	0.83
Apartments	75	0.70	0.73	0.79	0.86
Single Family (Soil Group C)					
1/8 Acre	50	0.55	0.58	0.64	0.73
1/4 Acre	38	0.48	0.51	0.57	0.68
1/3 Acre	30	0.43	0.46	0.53	0.65
1/2 Acre	25	0.40	0.43	0.50	0.63
3/4 Acre	22	0.39	0.42	0.49	0.62
1 Acre	20	0.37	0.40	0.48	0.61
Multi-Family (Soil Group C)					
Multi-Unit (detached)	60	0.60	0.63	0.69	0.77
Multi-Unit (attached)	65	0.63	0.66	0.71	0.79
Apartments	75	0.68	0.72	0.77	0.83
Single-Family (Soil Group B)					
1/8 Acre	50	0.52	0.54	0.59	0.67
1/4 Acre	38	0.44	0.46	0.52	0.61
1/3 Acre	30	0.39	0.41	0.47	0.57
1/2 Acre	25	0.36	0.38	0.44	0.54
3/4 Acre	22	0.34	0.36	0.42	0.52
1 Acre	20	0.33	0.35	0.40	0.51
Multi-Family (Soil Group B)					
Multi-Unit (detached)	60	0.58	0.60	0.65	0.72
Multi-Unit (attached)	65	0.61	0.64	0.68	0.75
Apartments	75	0.67	0.70	0.74	0.80

Land Use or Surface Characteristics	Percent Impervious	Frequency				
		<u>2</u>	<u>5</u>	<u>10</u>	<u>25</u>	<u>100</u>
<u>Single Family (Soil Group A)</u>						
1/8 Acre	50	0.47	0.50	0.54		0.60
1/4 Acre	38	0.39	0.41	0.45		0.52
1/3 Acre	30	0.33	0.35	0.39		0.47
1/2 Acre	25	0.30	0.31	0.35		0.44
3/4 Acre	22	0.28	0.29	0.33		0.42
1 Acre	20	0.26	0.28	0.32		0.40
<u>Multi-Family (Soil Group A)</u>						
Multi-Unit (detached)	60	0.55	0.57	0.61		0.67
Multi-Unit (attached)	65	0.58	0.60	0.64		0.70
Apartments	75	0.65	0.68	0.72		0.77
3. Industrial:						
Light Areas	70	0.68	0.69	0.73		0.80
Heavy Areas	80	0.74	0.76	0.79		0.84
4. Playgrounds:	15	0.33	0.35	0.42		0.55
Schools:	40	0.49	0.51	0.56		0.66
Railroad Yard Areas:	30	0.43	0.45	0.50		0.62
7. Undeveloped Urban Areas: Offsite Flow Analysis (when land use not defined)	45	0.52	0.54	0.59		0.68
8. Streets:						
Paved	99	0.87	0.88	0.90		0.93
Gravel	00	0.24	0.26	0.33		0.48
9. Drive, Parking Lots and Walks:	96	0.87	0.87	0.88		0.89
10. Roofs:	90	0.80	0.85	0.90		0.93
11. Urban Lawn Areas (See Note No. 1 below):						
<u>Soil Group A</u>						
Slope less than 1%	00	0.08	0.09	0.13		0.23
Slope 1% to 4%	00	0.12	0.13	0.17		0.27
Slope more than 4%	00	0.16	0.17	0.21		0.31
<u>Soil Group B</u>						
Slope less than 1%	00	0.16	0.26	0.18		0.37
Slope 1% to 4%	00		0.20	0.22		0.41
Slope more than 4%	00		0.24	0.26		0.45
<u>Soil Group C</u>						
Slope less than 1%	00	0.24	0.27	0.35		0.51
Slope 1% to 4%	00	0.26	0.29	0.37	0.40	0.53
Slope more than 4%	00	0.28	0.31	0.39		0.55

<u>Land Use or Surface Characteristics</u>	<u>Percent Impervious</u>	<u>Frequency</u>			
		<u>2</u>	<u>5</u>	<u>10</u>	<u>100</u>
<u>Soil Group D</u>					
Slope less than 1%	00	0.28	0.33	0.43	0.63
Slope 1% to 4%	00	0.30	0.35	0.45	0.65
Slope more than 4%	00	0.32	0.37	0.47	0.67

Note No. 1: Coefficients shown in the above table are for pervious open space areas with thick turf which includes pervious areas in parks and cemeteries. Coefficients shown above must be increased 0.02 for use with agricultural pasture areas. Coefficients shown above must be reduced by 0.04 for use with agricultural cultivated areas. Group A soils are well-drained, coarse textured sands with high infiltration rates. Group B soils are moderately well-drained, moderately coarse textured soils with moderate infiltration rates. Group C soils are moderately poor-drained, moderately fine textured soils with slow infiltration rates. Group D soils are poor-drained, fine textured soils with very slow infiltration rates.

GENERAL NOTE: These Rational Formula Coefficients may not be valid for large basins.

# RAINFALL INTENSITIES

## SEDGWICK COUNTY KANSAS (revised June 1997)

This table contains average rainfall intensities in inches per hour.

DURATION, HR:MIN	RETURN PERIOD						
	1 YR	2 YR	5 YR	10 YR	25 YR	50 YR	100 YR
0:05	4.91	5.64	6.64	7.38	8.48	9.34	10.20
0:06	4.62	5.34	6.33	7.07	8.15	9.00	9.84
0:07	4.38	5.09	6.08	6.80	7.86	8.69	9.52
0:08	4.17	4.87	5.85	6.56	7.60	8.41	9.22
0:09	4.00	4.68	5.63	6.33	7.34	8.14	8.93
0:10	3.84	4.50	5.43	6.11	7.10	7.87	8.64
0:11	3.70	4.34	5.25	5.90	6.86	7.61	8.36
0:12	3.56	4.19	5.07	5.71	6.64	7.36	8.09
0:13	3.44	4.05	4.91	5.53	6.43	7.14	7.84
0:14	3.33	3.92	4.76	5.36	6.24	6.92	7.61
0:15	3.22	3.80	4.62	5.21	6.06	6.73	7.40
0:16	3.12	3.69	4.49	5.07	5.91	6.56	7.21
0:17	3.03	3.58	4.37	4.94	5.76	6.40	7.04
0:18	2.94	3.48	4.26	4.82	5.63	6.26	6.88
0:19	2.85	3.39	4.16	4.71	5.50	6.12	6.74
0:20	2.77	3.30	4.06	4.60	5.38	5.99	6.60
0:21	2.70	3.22	3.97	4.50	5.27	5.87	6.47
0:22	2.63	3.14	3.88	4.41	5.17	5.76	6.35
0:23	2.56	3.07	3.80	4.32	5.07	5.65	6.23
0:24	2.50	3.00	3.72	4.23	4.97	5.54	6.12
0:25	2.44	2.93	3.64	4.15	4.88	5.44	6.01
0:26	2.38	2.87	3.57	4.07	4.79	5.35	5.90
0:27	2.33	2.81	3.50	4.00	4.70	5.26	5.80
0:28	2.27	2.75	3.44	3.92	4.62	5.17	5.71
0:29	2.23	2.69	3.37	3.86	4.54	5.08	5.61
0:30	2.18	2.64	3.31	3.79	4.47	4.99	5.52
0:31	2.14	2.59	3.26	3.72	4.39	4.91	5.43
0:32	2.09	2.54	3.20	3.66	4.32	4.83	5.34
0:33	2.05	2.50	3.14	3.60	4.25	4.76	5.26
0:34	2.02	2.45	3.09	3.54	4.18	4.68	5.18
0:35	1.98	2.41	3.04	3.48	4.12	4.61	5.10
0:36	1.94	2.37	2.99	3.43	4.05	4.54	5.02
0:37	1.91	2.33	2.94	3.38	3.99	4.47	4.95
0:38	1.88	2.29	2.90	3.32	3.93	4.40	4.87
0:39	1.85	2.25	2.85	3.27	3.87	4.34	4.80
0:40	1.82	2.22	2.81	3.23	3.82	4.28	4.73
0:41	1.79	2.18	2.77	3.18	3.76	4.22	4.67
0:42	1.76	2.15	2.73	3.13	3.71	4.16	4.60
0:43	1.73	2.12	2.69	3.09	3.66	4.10	4.54
0:44	1.71	2.09	2.65	3.05	3.61	4.04	4.48
0:45	1.68	2.06	2.62	3.01	3.56	3.99	4.42
0:46	1.66	2.03	2.58	2.96	3.51	3.94	4.36
0:47	1.63	2.00	2.55	2.93	3.47	3.89	4.30
0:48	1.61	1.97	2.51	2.89	3.42	3.84	4.25
0:49	1.59	1.95	2.48	2.85	3.38	3.79	4.20
0:50	1.57	1.92	2.45	2.81	3.34	3.74	4.15

# RAINFALL INTENSITY TABLE

## SEDGWICK COUNTY KANSAS (revised June 1997)

This table contains average rainfall intensities in inches per hour.

DURATION, HR:MIN	RETURN PERIOD						
	1 YR	2 YR	5 YR	10 YR	25 YR	50 YR	100 YR
0:51	1.55	1.90	2.42	2.78	3.30	3.70	4.10
0:52	1.53	1.87	2.39	2.75	3.26	3.65	4.05
0:53	1.51	1.85	2.36	2.71	3.22	3.61	4.00
0:54	1.49	1.83	2.33	2.68	3.18	3.57	3.95
0:55	1.47	1.80	2.30	2.65	3.14	3.53	3.91
0:56	1.45	1.78	2.28	2.62	3.11	3.49	3.86
0:57	1.43	1.76	2.25	2.59	3.07	3.45	3.82
0:58	1.41	1.74	2.22	2.56	3.04	3.41	3.78
0:59	1.40	1.72	2.20	2.53	3.01	3.37	3.74
1:00	1.38	1.70	2.17	2.50	2.97	3.34	3.70
1:05	1.30	1.61	2.06	2.38	2.82	3.17	3.52
1:10	1.23	1.53	1.96	2.26	2.69	3.02	3.35
1:15	1.17	1.45	1.87	2.16	2.57	2.89	3.20
1:20	1.11	1.38	1.79	2.06	2.46	2.77	3.07
1:25	1.06	1.32	1.71	1.98	2.36	2.65	2.95
1:30	1.01	1.27	1.64	1.90	2.27	2.55	2.83
1:35	0.97	1.21	1.58	1.83	2.18	2.46	2.73
1:40	0.93	1.16	1.52	1.76	2.10	2.37	2.63
1:45	0.89	1.12	1.46	1.70	2.03	2.29	2.54
1:50	0.86	1.08	1.41	1.64	1.96	2.21	2.46
1:55	0.82	1.04	1.36	1.58	1.89	2.13	2.38
2:00	0.79	1.00	1.31	1.53	1.83	2.07	2.30
2:05	0.76	0.97	1.27	1.48	1.77	2.00	2.23
2:10	0.74	0.93	1.23	1.43	1.72	1.94	2.16
2:15	0.71	0.90	1.19	1.39	1.67	1.88	2.10
2:20	0.69	0.87	1.15	1.35	1.62	1.83	2.04
2:25	0.66	0.85	1.12	1.31	1.57	1.78	1.98
2:30	0.64	0.82	1.09	1.27	1.53	1.73	1.93
2:35	0.62	0.80	1.06	1.24	1.49	1.68	1.88
2:40	0.61	0.78	1.03	1.21	1.45	1.64	1.83
2:45	0.59	0.75	1.01	1.18	1.42	1.60	1.79
2:50	0.57	0.74	0.98	1.15	1.38	1.56	1.74
2:55	0.56	0.72	0.96	1.12	1.35	1.53	1.70
3:00	0.55	0.70	0.94	1.10	1.32	1.49	1.67
3:15	0.51	0.66	0.88	1.03	1.24	1.40	1.57
3:30	0.48	0.62	0.83	0.97	1.17	1.32	1.48
3:45	0.45	0.59	0.78	0.92	1.11	1.26	1.40
4:00	0.43	0.56	0.75	0.88	1.06	1.20	1.34
4:15	0.41	0.53	0.71	0.84	1.01	1.14	1.28
4:30	0.40	0.51	0.68	0.80	0.97	1.10	1.22
4:45	0.38	0.49	0.66	0.77	0.93	1.05	1.17
5:00	0.37	0.47	0.63	0.74	0.89	1.01	1.13
5:15	0.36	0.46	0.61	0.72	0.86	0.98	1.09
5:30	0.35	0.44	0.59	0.69	0.83	0.94	1.05
5:45	0.34	0.43	0.57	0.67	0.81	0.91	1.02
6:00	0.33	0.42	0.55	0.65	0.78	0.88	0.98

$Q L = 5' : P = 5 + 1.8(2') = 8.6$   
 $Q L = 10' : P = 10 + 1.8(2) = 13.6$

REMINGTON PLACE 2<sup>ND</sup>

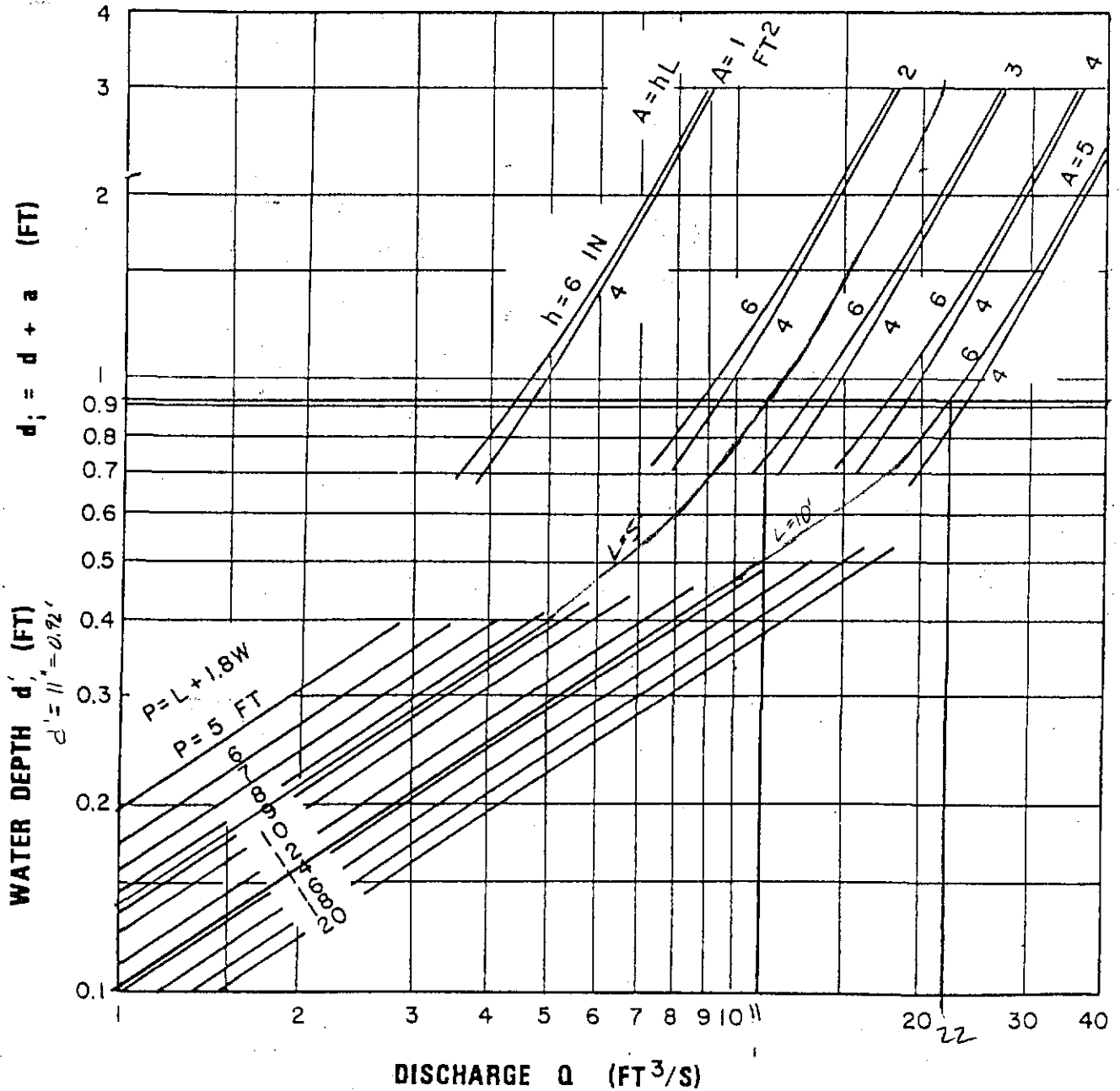
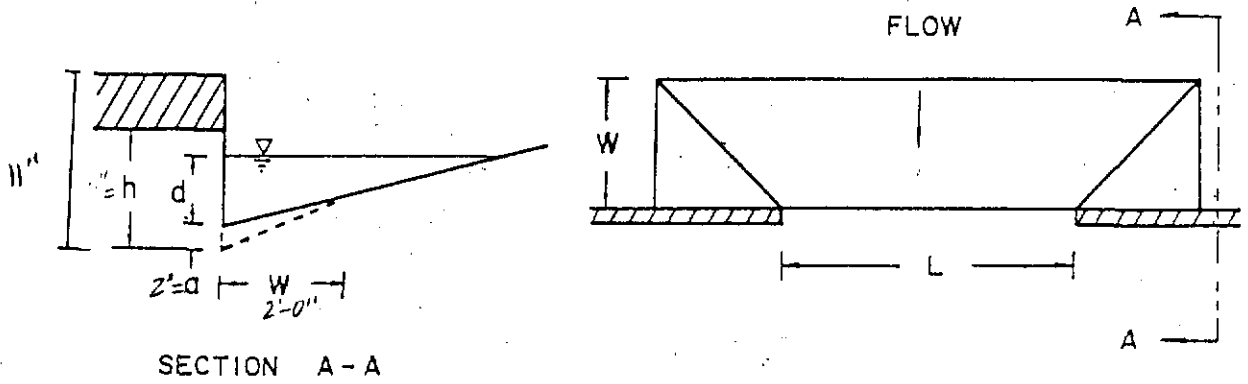

CHART 12. Depressed curb-opening inlet capacity in sump locations.



303 S. TOPEKA • WICHITA, KANSAS 67202

Project \_\_\_\_\_

Date \_\_\_\_\_

316-262-2691 • FAX 316-262-3003

Item \_\_\_\_\_

By \_\_\_\_\_

www.pec1.com • designers@pec1.com

DETERMINE CAPACITIES OF STANDARD CURVE STREETS

(32' R-O-W)

\* ASSUME FLOW CARRIED BY STREET ONLY

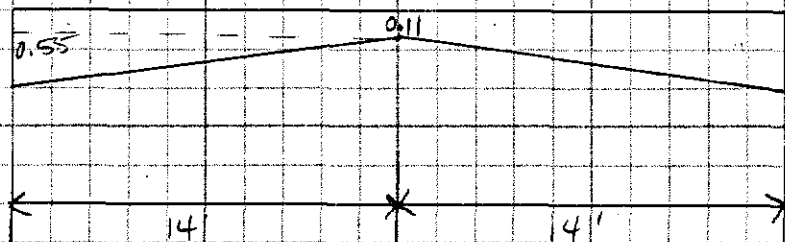

$$n = \frac{(2 \times 2.55 \times 0.013) + (2 \times 12 \times 0.016)}{29.1} = 0.01547$$

$$A = (2 \times \frac{1}{2} \times 14 \times 0.44) + (0.11 \times 28) = 9.24 \text{ SF}$$

$$P = 29.1$$

$$R = \frac{A}{P} = \frac{9.24}{29.1} = 0.318$$

$$Q = \frac{1.486}{n} A R^{2/3} S^{1/2}$$

$$Q = \frac{1.486}{0.01547} (9.24)(0.318)^{2/3} (S)^{1/2}$$

$$Q = 413.5 \sqrt{S}$$