

0.50'E
2558.64'

Scale: 1" = 60'

NOTES:
Proposed Top of Foundation Elevations Are Shown On Plans. Contractor to Set Finished Floor Elevations.

All Street Elevations Shown on Plans Are for Top of Curb (Full-Height).

This Grading Plan is Designed with Walk-out & View-Out Basements. Elevations Shown as (XX.X V.O. or XX.X W.O.)

Lot dimensions have been omitted on this plan, refer to the recorded plat for this information.

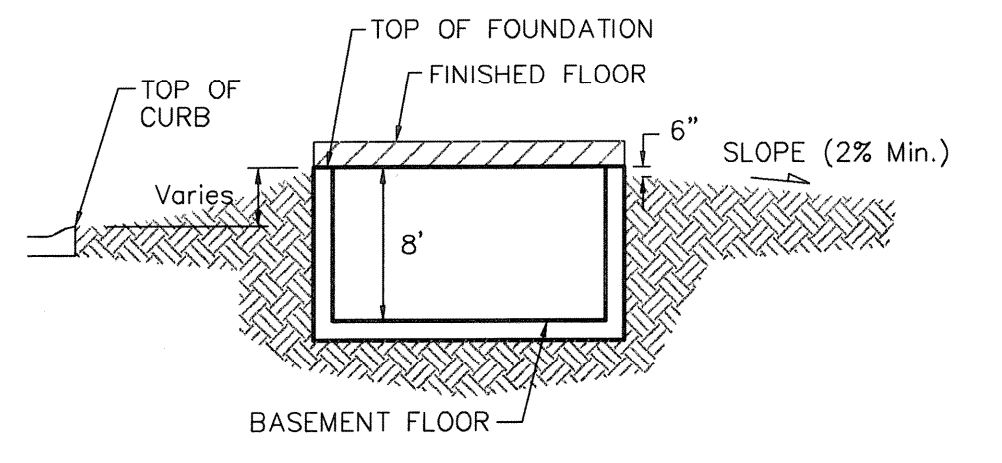

TYPICAL NON-VIEW OUT DETAIL
NO SCALE

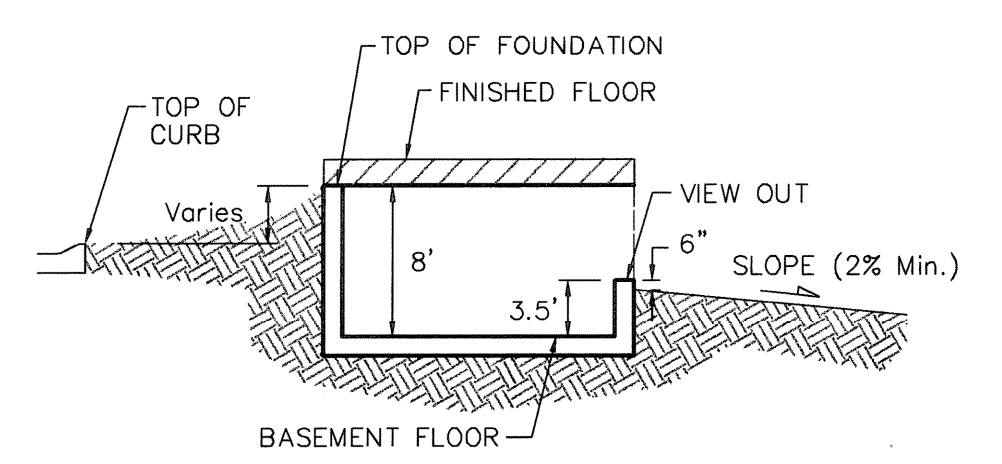

TYPICAL VIEW OUT DETAIL
NO SCALE

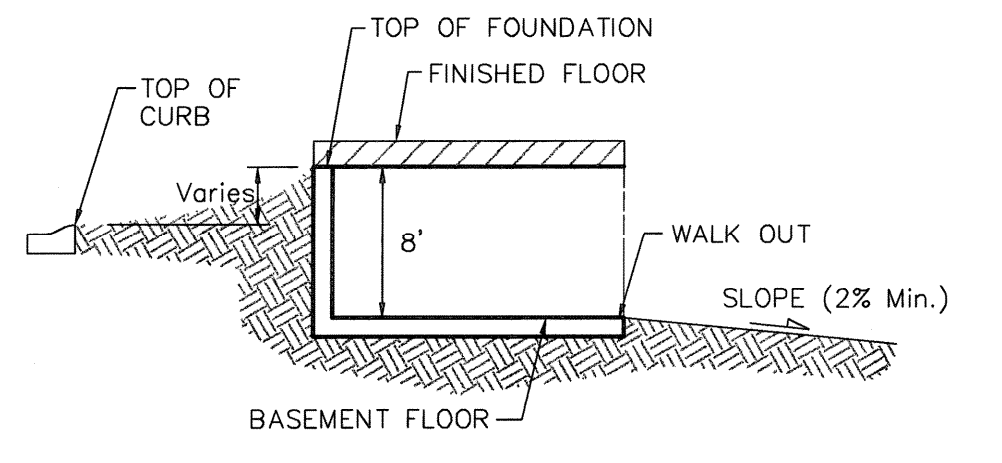

TYPICAL WALK OUT DETAIL
NO SCALE

Lots shown with "⊕" symbol indicates that extra deep foundations may be required.

Ⓜ Indicates Non-Typical View-Out (Use 5.5' From T.F. to V.O.)



Phase 1 - Turkey Creek 3rd

- Lots 119-143, Block A
- Lots 1-17, Block B
- Lots 28-32, Block F
- Lots 1, 16-32, Block G

MINIMUM BUILDING PAD ELEVATIONS FOR LOWEST OPENING TO THE STRUCTURES		
LOT	BLOCK	ELEVATION
16-19, 21-36	A	1354.0
91-93, 106-108	A	1329.0
109-114	A	1330.0
115-117	A	1331.0
118-128	A	1333.7
129-133	A	1334.0
1-8, 13-20	F	1343.5
41-49	F	1343.0
2-9	H	1341.0
36-40	H	1341.0
60-64	H	1340.0
66-73	H	1340.0
75-77	H	1341.0

Trukey Creek 3rd Addition
Grading Plan
 Baughman Company, P.A. 315 E. St. W. Wichita, KS 67211 P: 316.262.7271 F: 316.262.6149
 ENGINEERING | SURVEYING | PLANNING | LANDSCAPE ARCHITECTURE

PROJECT NUMBER	DESIGN	DRAWN
01-07-2009	NBW	JAK
Revised one grade, added 100yr Boundary Line	APPROVED	DATE
		10/08
REVISIONS:	SCALE	
	1" = 60'	
	SHEET	

1 OF 10

