

TYPICAL NON-VIEW OUT DETAIL
NO SCALE

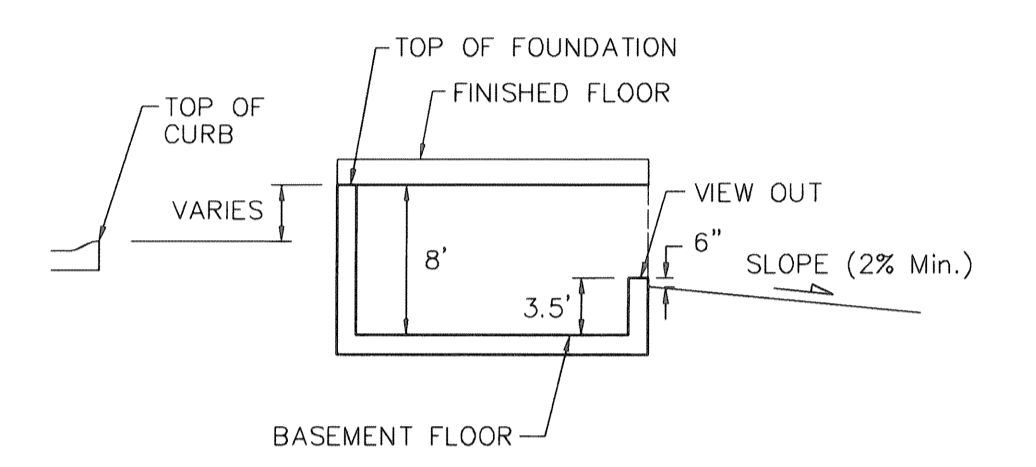

TYPICAL VIEW OUT DETAIL
NO SCALE

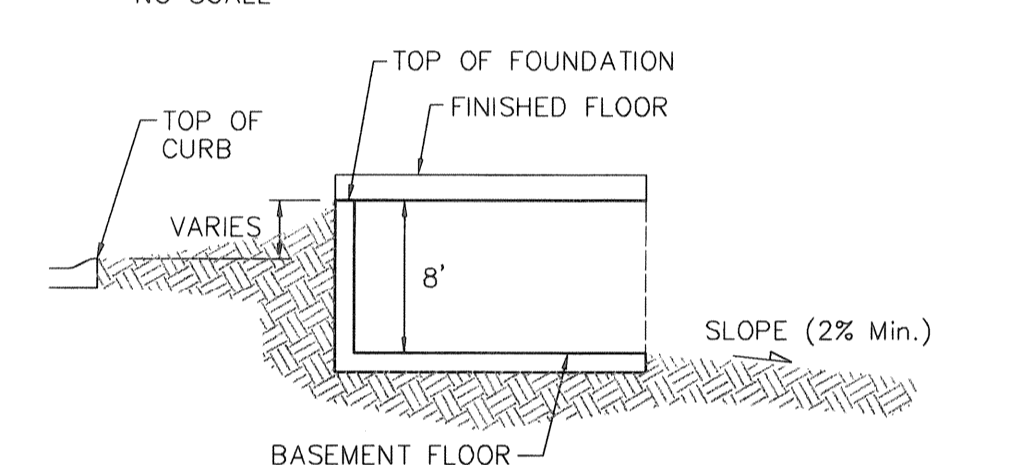

TYPICAL WALK OUT DETAIL
NO SCALE

BENCHMARK:
 BM #1: Small RR spike in 2nd PP north of K-42 Highway, west side of Maize
 Elev. = 143.61 (City Datum)

BM #2: Small RR spike in PP east of East 1/4 Corner (C)
 Elev. = 147.00 (City Datum)

BM #3: "□" Top Headwall southeast corner K-42 Highway and Maize (County BM with City Datum)
 Elev. = 144.04 (City Datum)

NOTES:
 Proposed Top of Foundation Elevations Are Shown On Plans. Contractor to Set Finished Floor Elevations.

All Street Elevations Shown on Plans Are for Top of Curb (Full-Height).

This Grading Plan is Designed with View-Outs. Elevations Shown at Rear of House (XX.X V.O.)

Lot dimensions have been omitted on this plan, refer to the recorded plat for this information.

* May Require Extra Deep Foundation

MINIMUM BUILDING PAD ELEVATIONS FOR LOWEST OPENING TO THE STRUCTURES			
LOT	BLOCK	ELEVATION	
		CITY DATUM	NGVD29
16-22	B	144.5	1331.9
24-38	B	144.5	1331.9
40-47	B	144.5	1331.9

Phase 3 - Harvest Ridge

Lots 34-71, Block A
 Lots 1-17, Block C
 Lots 1-2, Block D

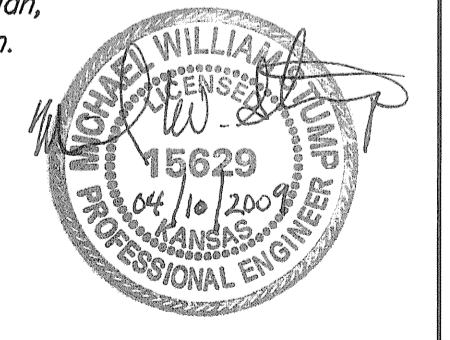

Baughman		HARVEST RIDGE ADDITION	
Grading Plan		Phase 3	
Wichita, Sedgewick County, Kansas			
Baughman Company, P.A. 315 Ellis St. Wichita, KS 67211 P 316-262-7271 F 316-262-0149			
ENGINEERING SURVEYING PLANNING LANDSCAPE ARCHITECTURE			
PROJECT NUMBER	DESIGN BLP	DRAWN MWS	
REVISIONS: 04/10/09 Revised Phase 3	MWS	APPROVED	DATE 3/22/04
		SCALE 1" = 60'	
		SHEET	3 OF 3