

UTILITY PLAN HAAG INDUSTRIAL PARK WICHITA, SEDGWICK COUNTY, KANSAS

OWNER:
Roger J. & Marsha M. Haag
1612 West Lynn
Wichita, KS 67212
316-943-5878

LEGAL DESCRIPTION:
The east 600 feet and the south 800 feet of that part of the NE1/4 of Sec. 9, Twp. 28-S, R-1-W of the 6th P.M., Sedgwick County, Kansas lying south of the Right of Way of the Atchison Topeka and Santa Fe Railroad; EXCEPT that part now platted as Caldwell Equipment Addition, Wichita, Sedgwick County Kansas, TOGETHER with two acres in square form in the SE corner of the NW1/4 of Sec. 9, Twp. 28-S, R-1-W of the 6th P.M., Sedgwick County, Kansas.

BENCHMARK:
Rail road spike in the north face of power pole 50.0 feet west and 402.0 feet north of the SE Cor. of the NE1/4 of Sec. 9, Twp. 28-S, R-1-W of the 6th P.M., Sedgwick County, Kansas.
Elev. = 120.21 City Datum (1307.61 NGVD)

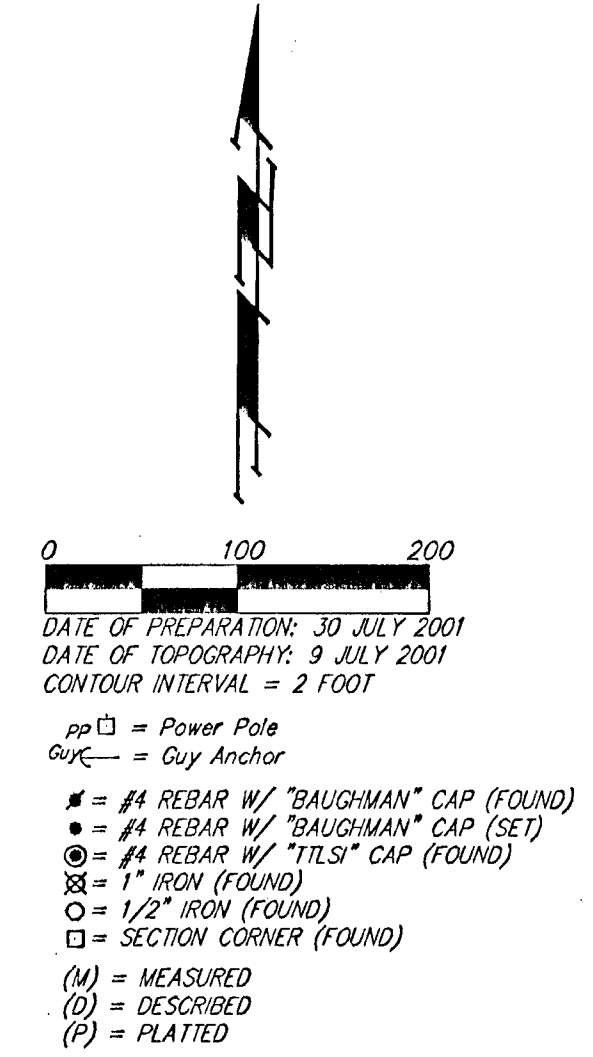

LEGEND

- Proposed Water Line (8" Unless Noted Otherwise)
- Proposed Sanitary Sewer Line (8" Unless Noted Otherwise)
- Proposed 4" Sanitary Sewer Force Main
- Proposed Sanitary Sewer Manhole
- ♀ Proposed Fire Hydrant

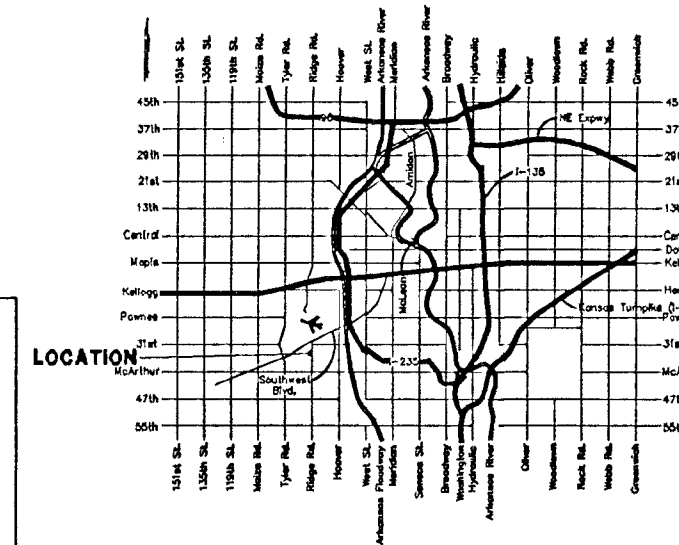

NW COR. NE1/4, SEC. 9
TWP. 28-S, R-1-W

NW COR. S1/2, NE1/4, SEC. 9
TWP. 28-S, R-1-W

1/16th Section Line

NE COR. S1/2, NE1/4, SEC. 9
TWP. 28-S, R-1-W

NE COR. NE1/4, SEC. 9
TWP. 28-S, R-1-W

Ex. SSMH

WICHITA AIRPORT AUTHORITY
2173 AIR CARGO RD.
WICHITA, KS 67209
ZONED "SF-6"

WICHITA AIRPORT AUTHORITY
2173 AIR CARGO RD.
WICHITA, KS 67209
ZONED "SF-6"

CESSIVA AIRCRAFT COMPANY
PO Box 7704
WICHITA, KS 67277
ZONED "SF-20"

ANDREW S. & KATHLEEN M. LAUER
4250 S. TYLER
WICHITA, KS 67215
ZONED "SF-20"