

MONARCH LANDING
SECOND ADDITION
WICHITA, KANSAS
LOT GRADING PHASE 2

DATE: AUGUST 2009

REVISED:

DESIGN BY: KLA

DRAWN BY: CMJ

CHECKED BY: GJA

SHEET NUMBER: **1**

NOTES:
1. BASEMENT WALLS ARE 8'-0". IF TALLER WALLS ARE USED THE TOP OF FOUNDATION WILL BE HIGHER AND ADDITIONAL STEPS MAY BE REQUIRED.

LEGEND

- CONIFEROUS TREE
- DECIDUOUS TREE
- SIGN
- POWER POLE
- ELECTRIC BOX
- LIGHT POLE
- FIRE HYDRANT
- WATER VALVE
- WATER METER
- SECTION CORNER
- BENCHMARK
- EASEMENT
- BUILDING SETBACK
- FENCE
- STORM SEWER PIPE
- WATER LINE
- SANITARY SEWER LINE
- GAS LINE
- GAS PIPELINE
- TELEPHONE LINE
- UNDERGROUND ELEC.
- OVERHEAD ELECTRIC
- FIBER OPTIC CABLE
- EXISTING CONTOURS
- PROPOSED CONTOURS
- TOP OF FOUNDATION ELEV.
- GARAGE PAD ELEV.
- ADDITIONAL STEPS NEEDED
- VIEW OUT WALL ELEV.
- WALK OUT ELEV.
- TOP OF WALL ELEV.
- MAN HOLE
- INLET
- STORM SEWER
- SANITARY SEWER
- WATER
- HIGH POINT
- MATCH EXISTING ELEV.
- DIRECTION OF PROPOSED DRAINAGE
- WALK OUT VIEW OUT INFORMATION
- EXISTING WALK OUT VIEW OUT INFORMATION
- SPOT ELEVATIONS
- WO - WALK OUT
- VO - VIEW OUT
- PVO - PARTIAL VIEW OUT
- PWO - PARTIAL WALK OUT
- NOVO - NO VIEW OUT

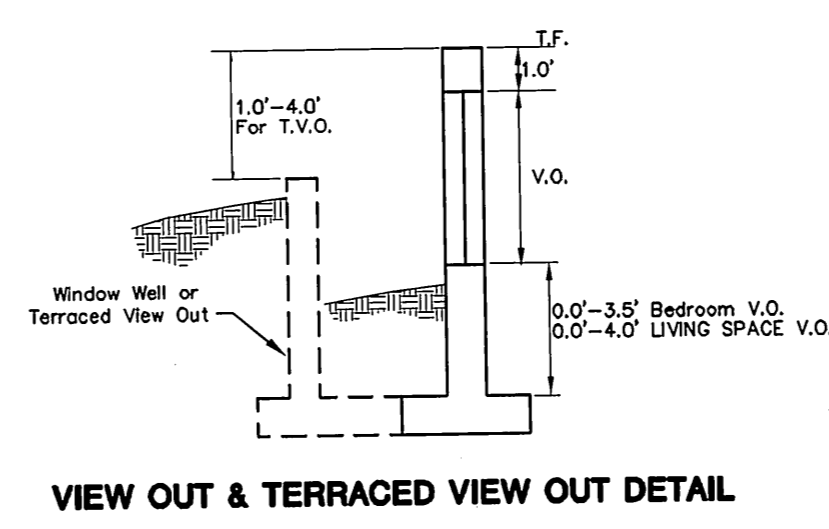
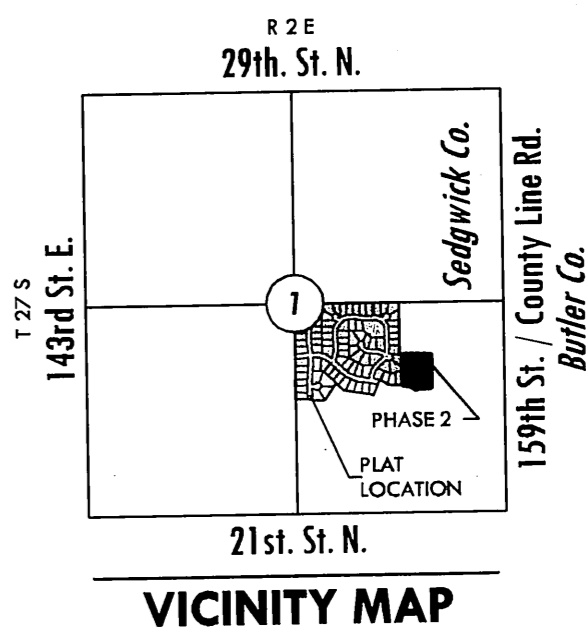
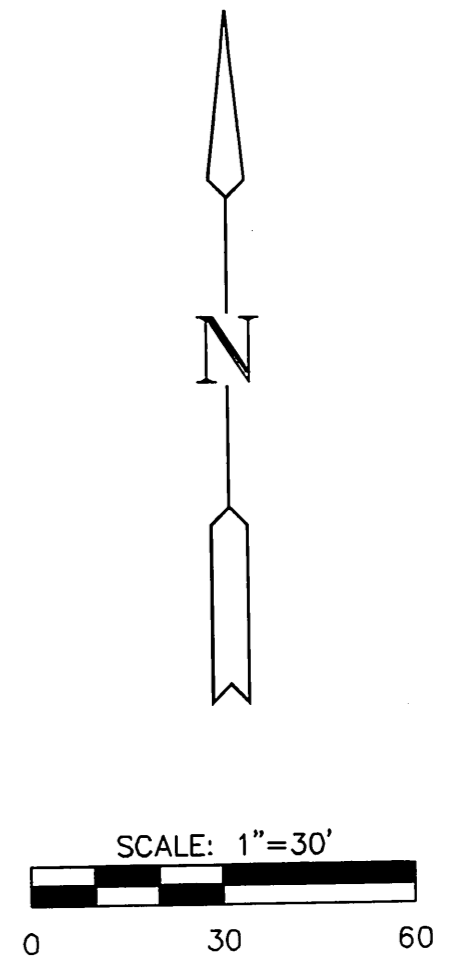

BENCH MARK
BM#1 Top of fence T-post 6" below ground, 8' NNE of the northwest corner of Lot 1, Blk. 2.
Elev. = 1375.29 NGVD 29.

REVISION HISTORY		
DATE	REVISION	REASON
9-4-09	INITIAL SUBMITTAL TO DEVELOPER	
9-15-09	MATCH CORNERS LOTS 1-3	C.O.W. COMMENTS
	SEALED	

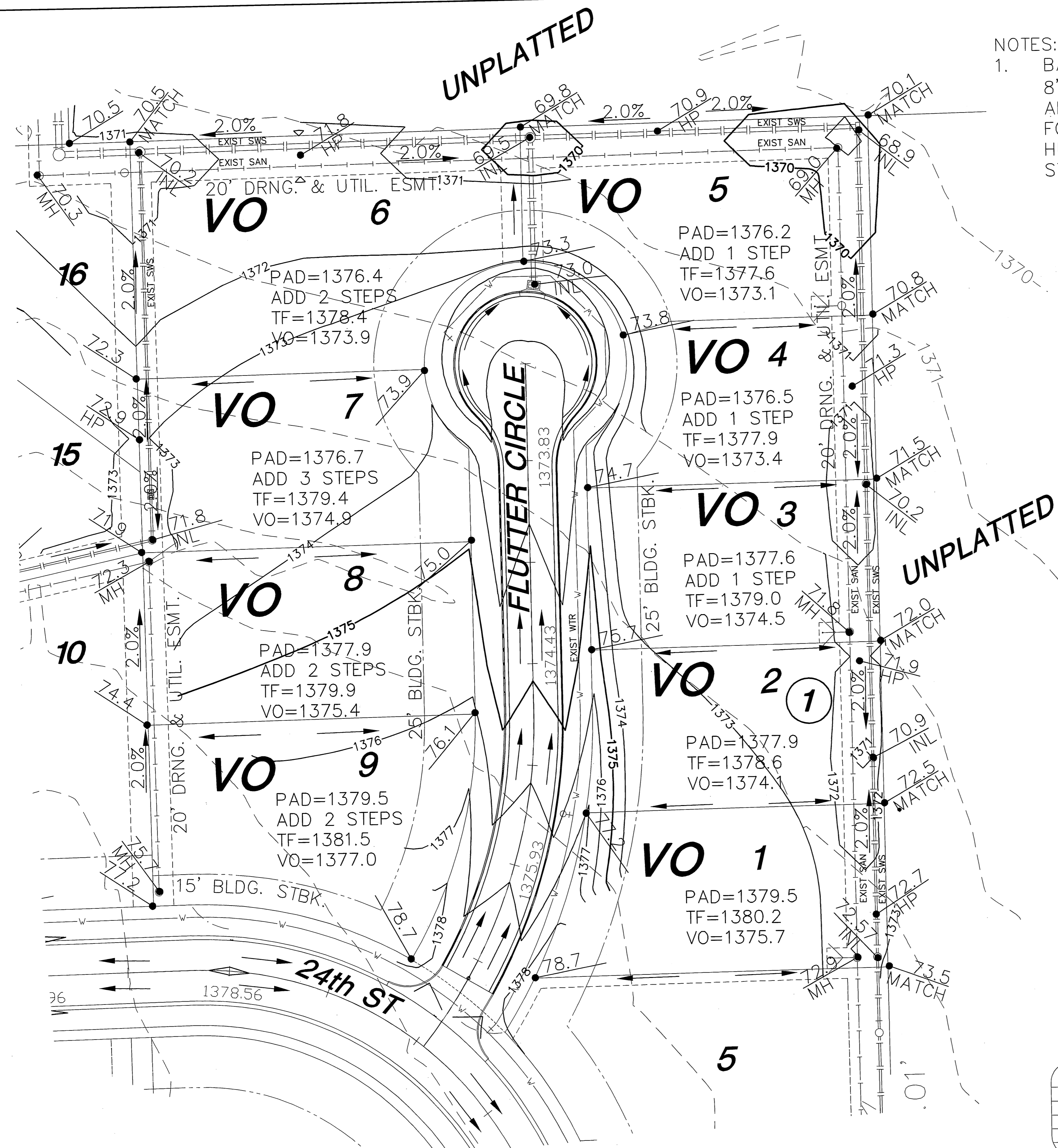

J:\Civil\06201\dwg\Grading\PHASE2\06201_Lgp_ph2.dwg