

WILLOW CREEK EAST 2nd ADDITION

4 Corner Grading Plan

Wichita, Sedgwick County, Kansas

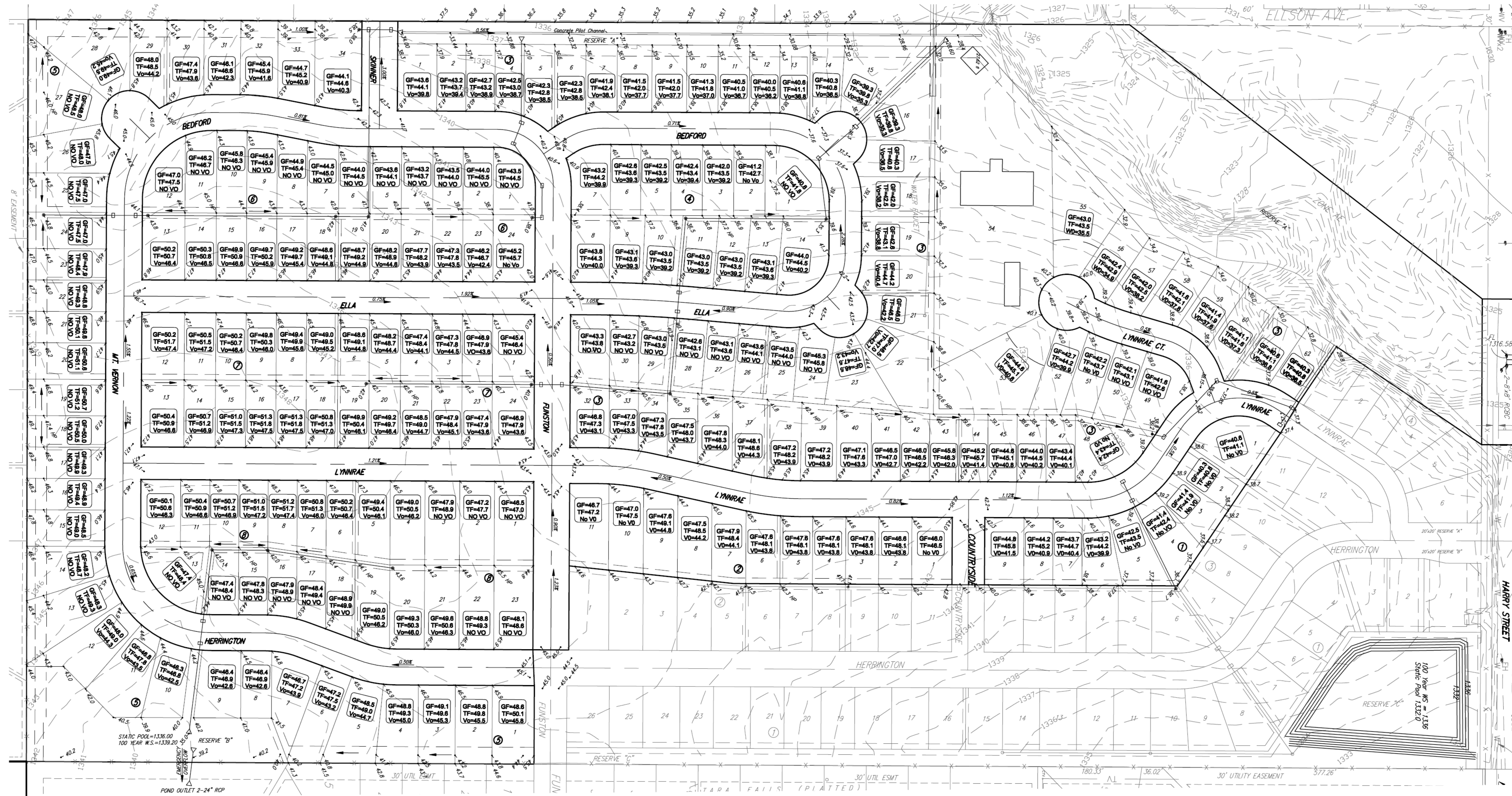
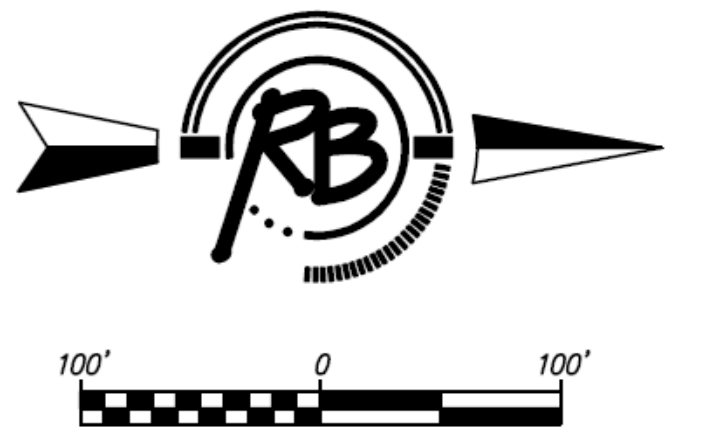

MINIMUM PAD ELEVATIONS		
LOTS	BLOCK	ELEVATION
7-12	5	1341.50
54-62	3	1331.00

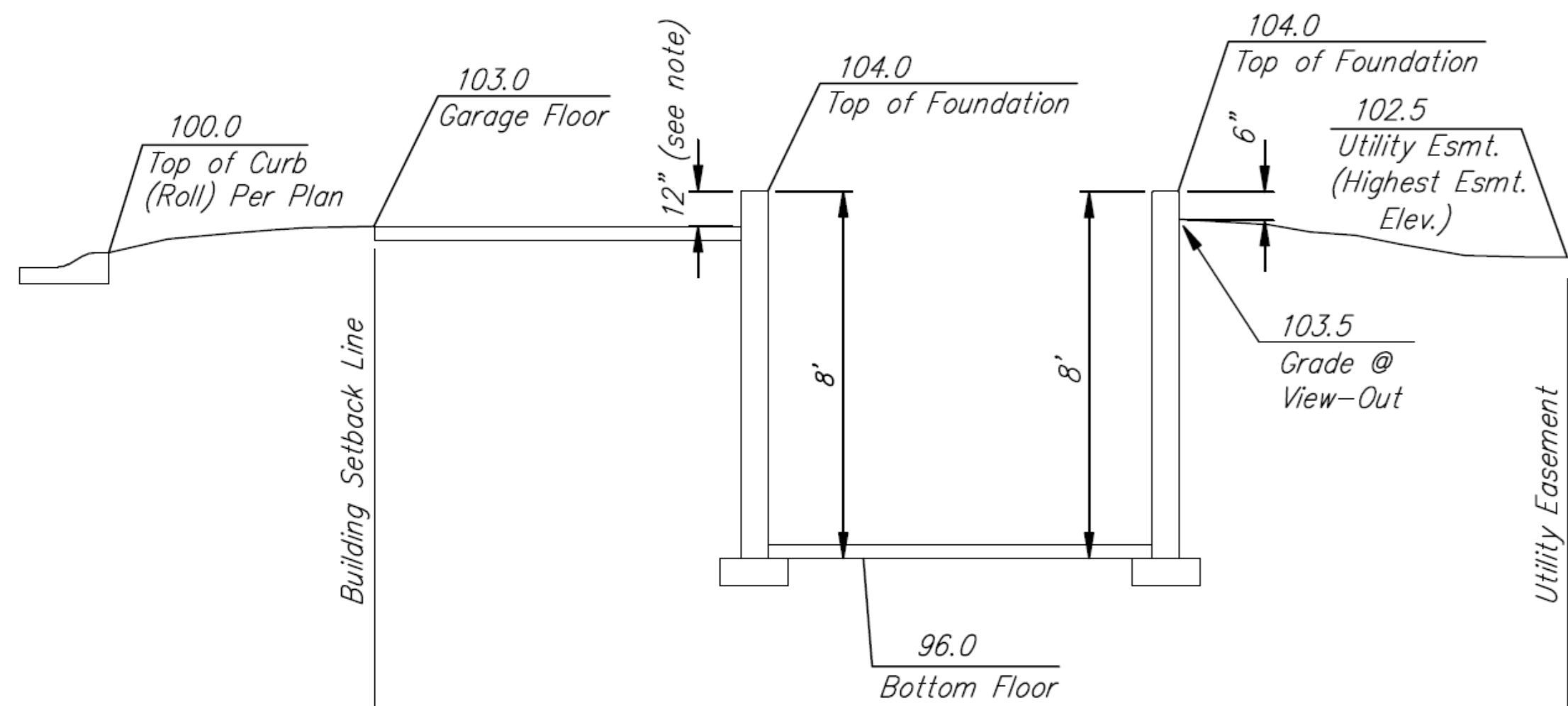

Section Through Typical Full Basement

* Varies (Check Individual Lot)

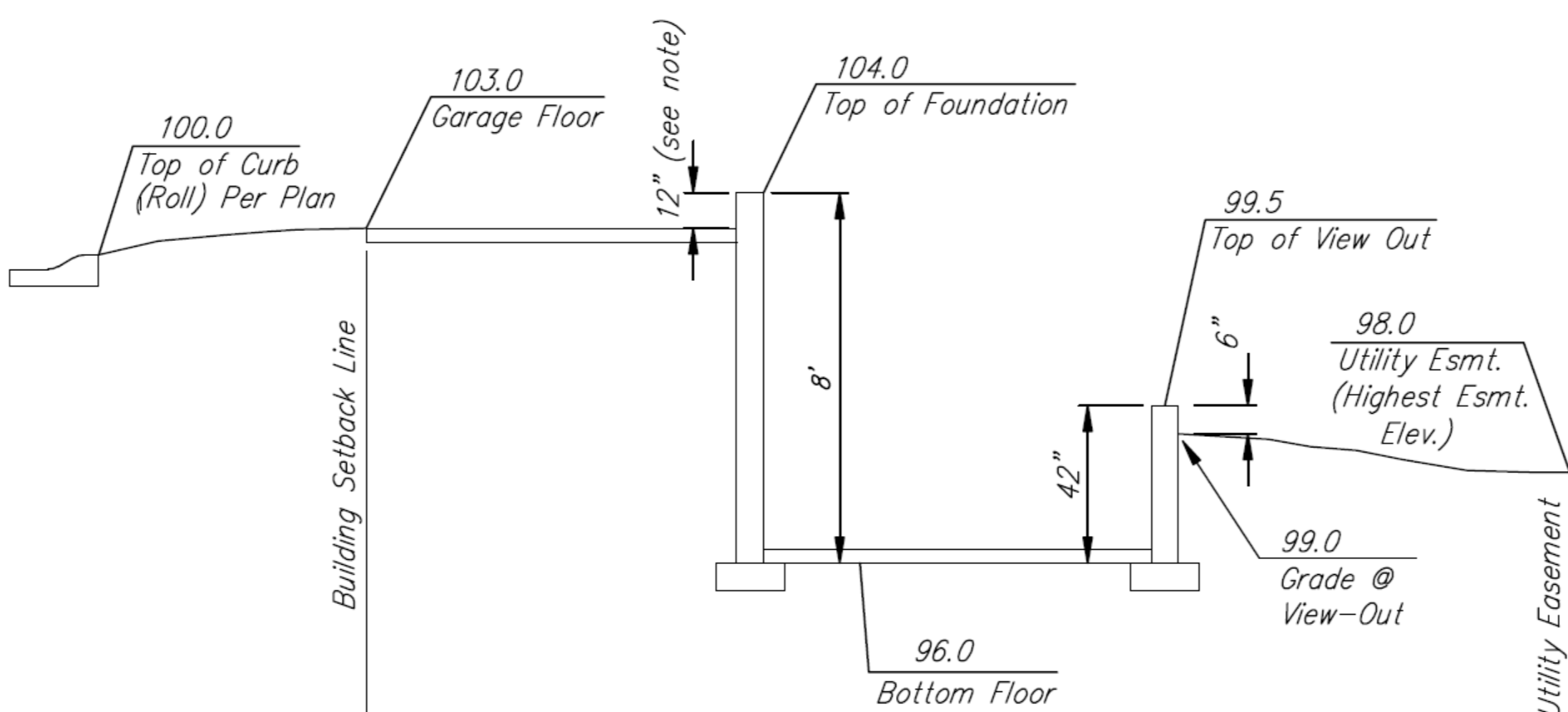

Section Through Typical View-Out Lot

* Varies (Check Individual Lot)

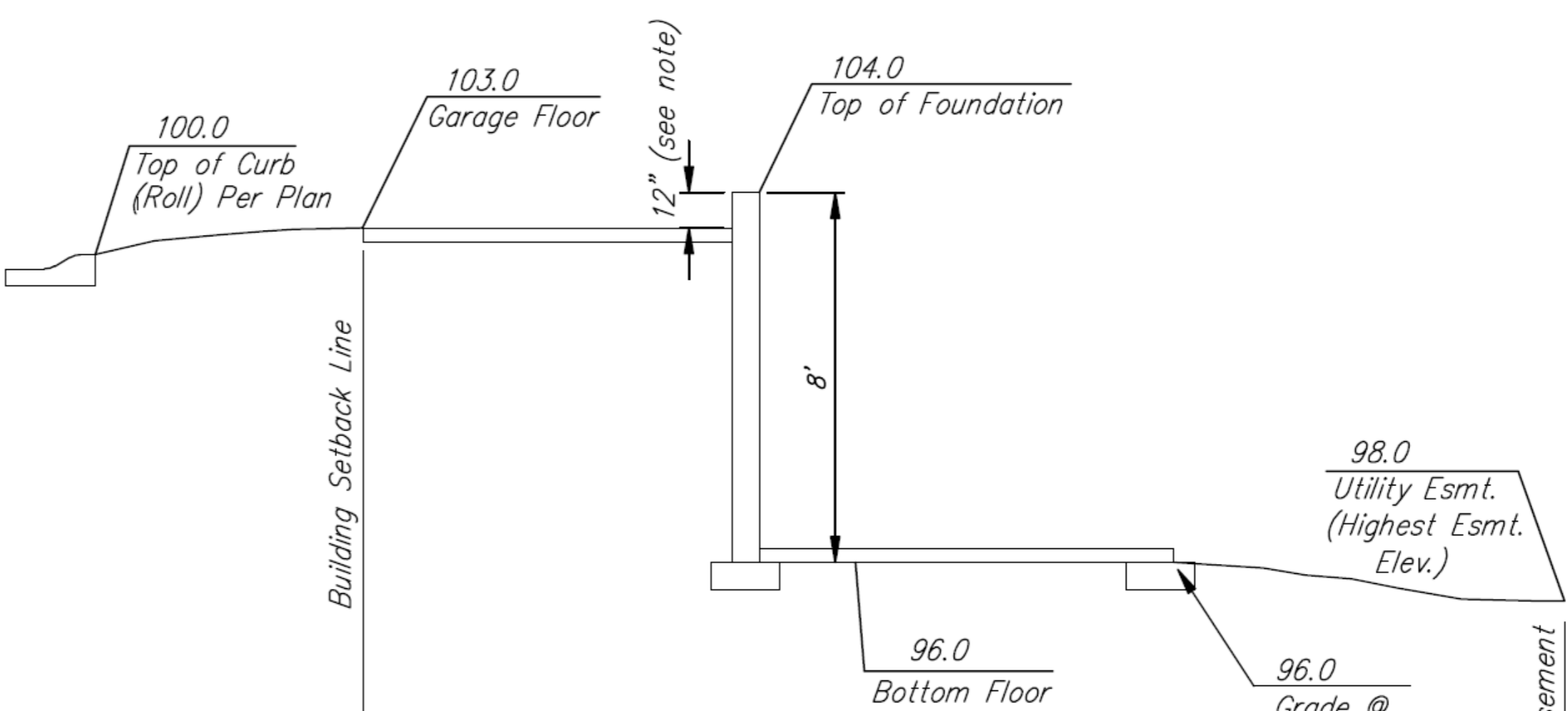

Section Through Typical Walk-Out Lot

* Varies (Check Individual Lot)



Revised 2-02-10

Ruggles & Bohm, P.A.
 Engineering, Surveying, Land Planning
 604 North Main
 Wichita, Kansas 67202
 www.rugglesandbohman.com
 (316) 264-6000
 (316) 264-4001 fax
 E-mail: info@rugglesandbohman.com