

# BELLECHASE

## Subdivision Grading Plan

Wichita, Sedgwick County, Kansas

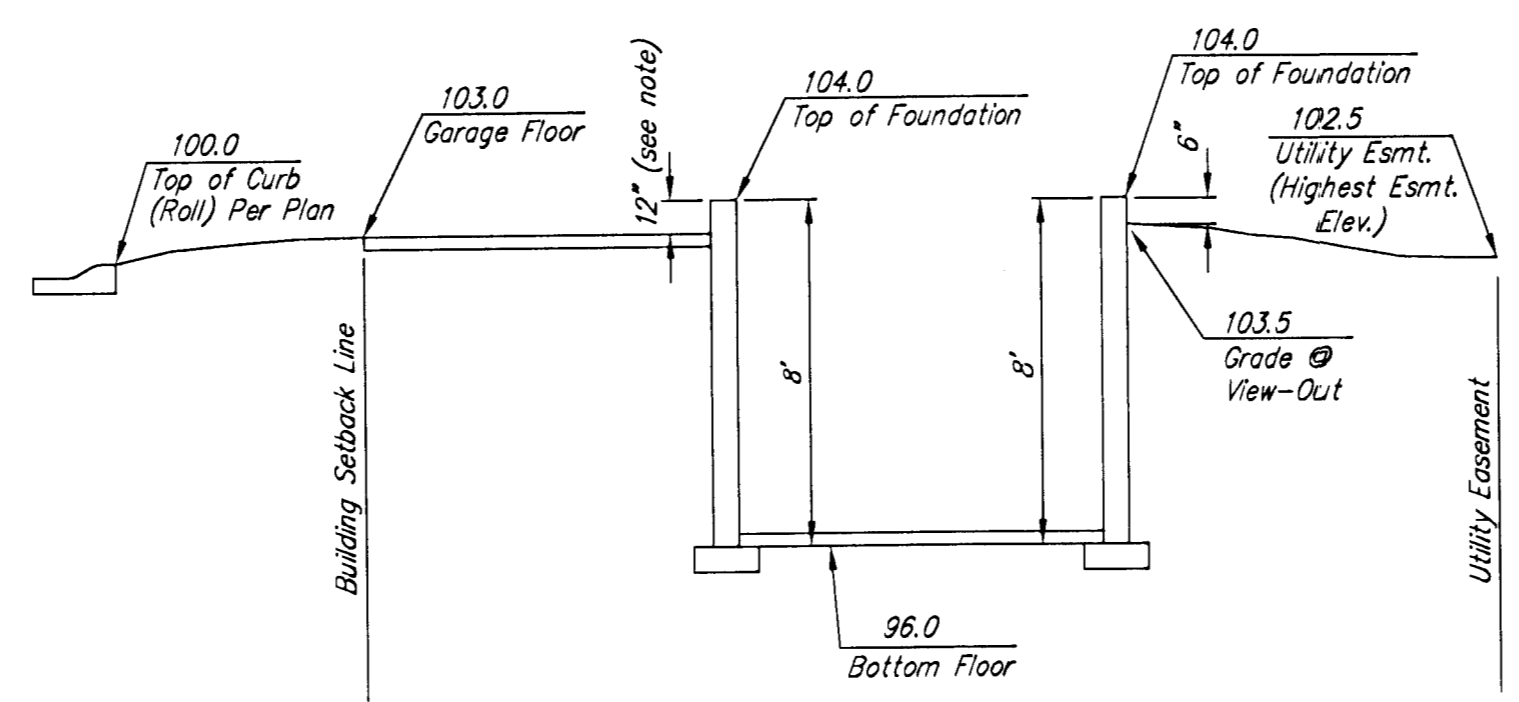
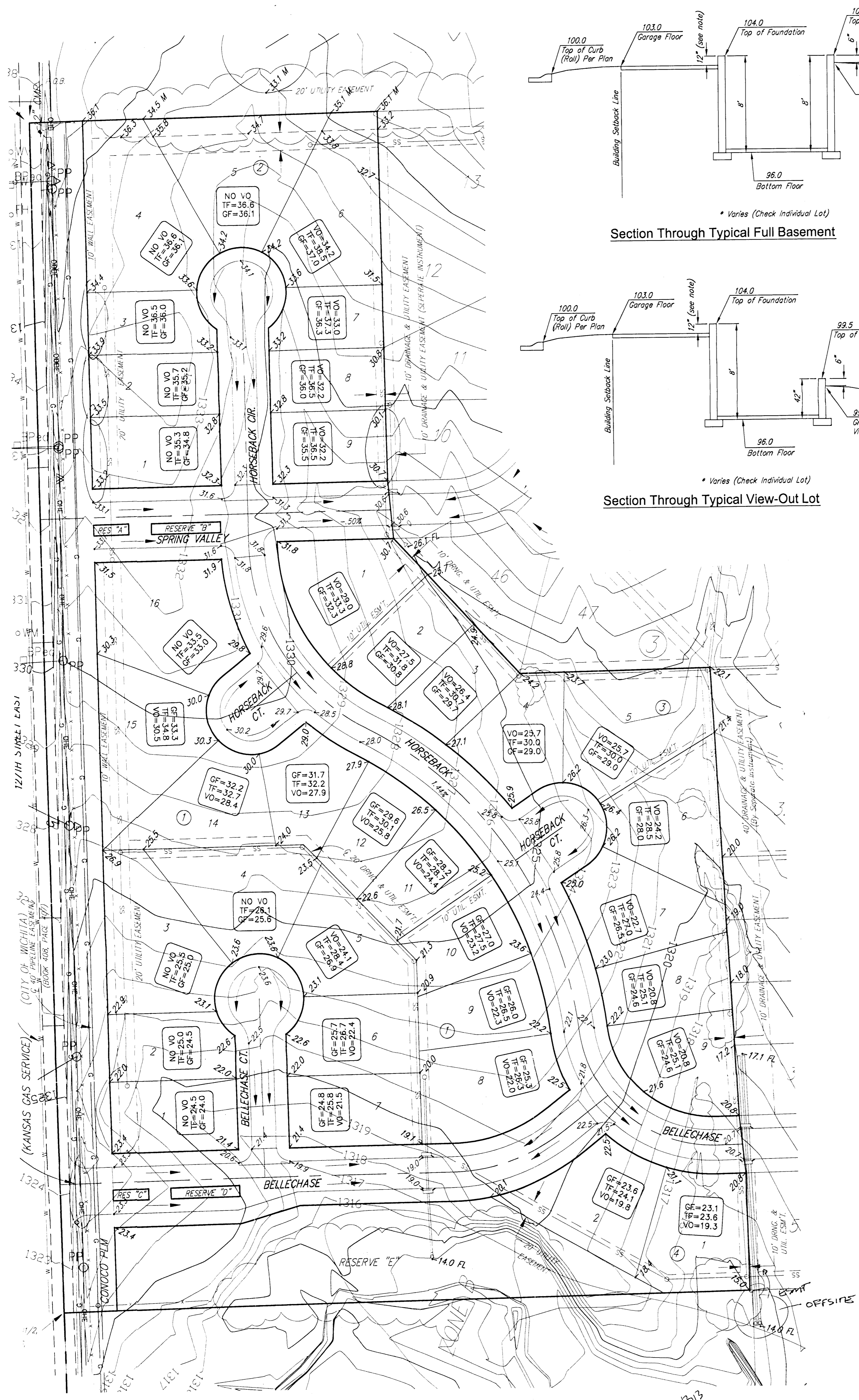

Section Through Typical Full Basement

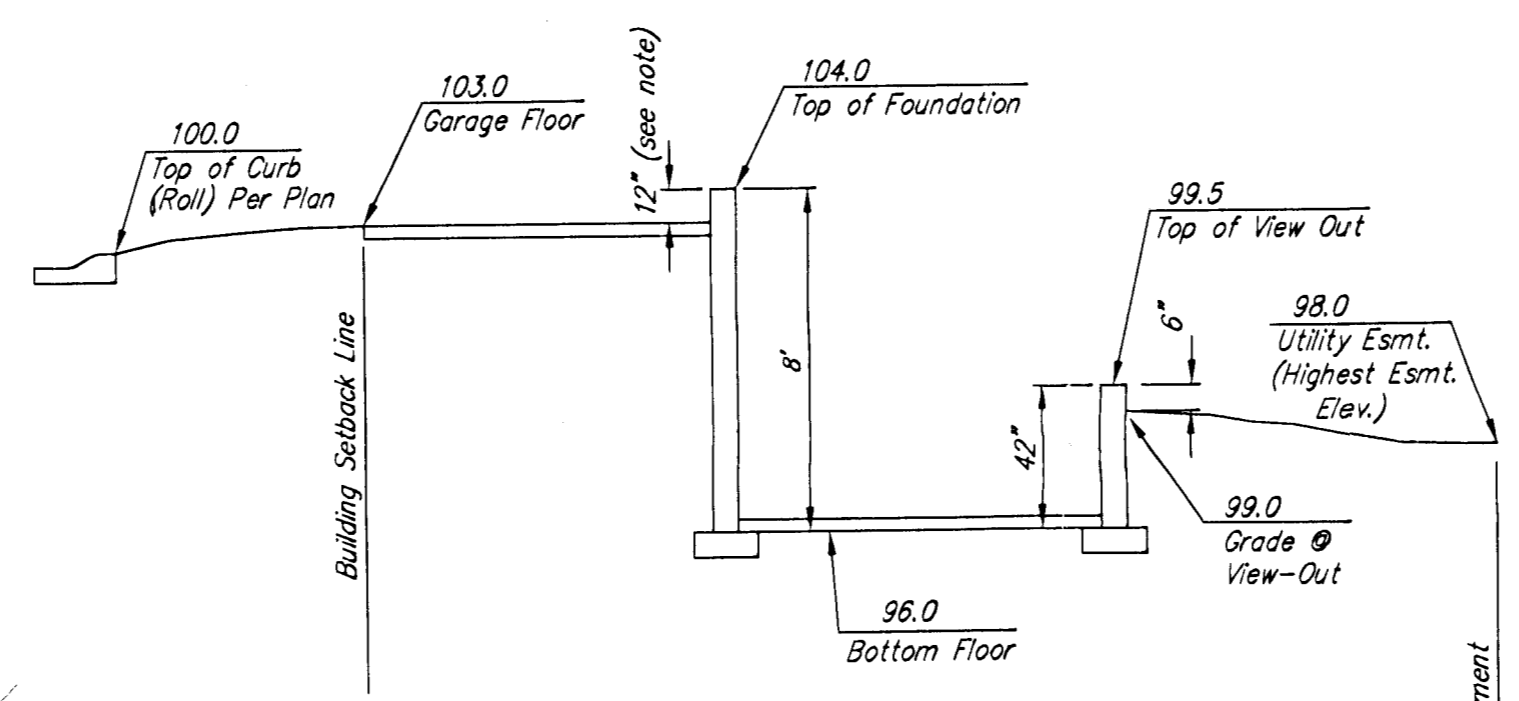

Section Through Typical View-Out Lot



BENCH MARK:  
RAILROAD SPIKE IN SOUTH FACE OF POWER  
POLE 79' SOUTH SOUTHEAST OF THE WEST  
QUARTER CORNER OF SEC. 26, 127S, R2E  
ELEV.=1337.46 (NGVD)

**LEGEND**  
 -XXX- Proposed Corner Grade  
 G=69.5 Proposed Garage Floor  
 TF=70.0 Proposed Top of Foundation  
 VO=65.7 Proposed Viewout Elevation

<b>BELLECHASE GRADING PLAN WICHITA, KANSAS</b>	
<p><b>Ruggles &amp; Bohm, P.A.</b> Engineering, Surveying, Land Planning 924 North Main (318) 284-8008 Wichita, Kansas 67203 (318) 284-4621 fax www.rbkansas.com E-mail: info@rbkansas.com</p>	DESIGN KWL DRAWN KWL REVIEW UTILITY DATE Feb. 7, 2008
	SHEET 1 OF 1 188 2738E