

REDMOND, CHRISTOPHER JOHN & ROSALYNN
 4048 W. 79TH ST.
 PRAIRIE VILLAGE, KS

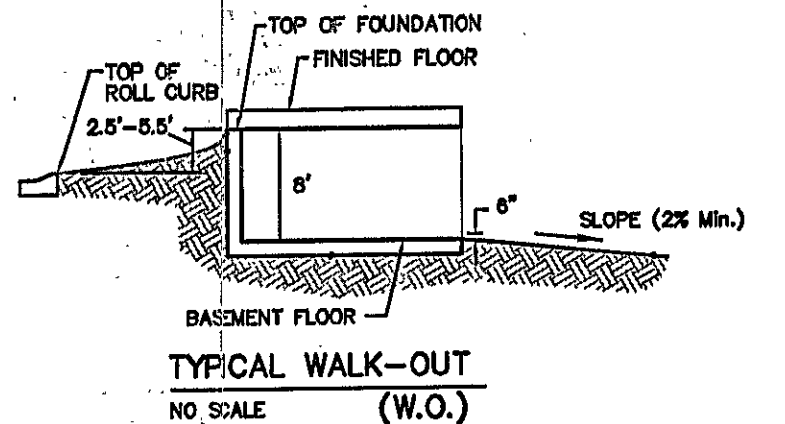
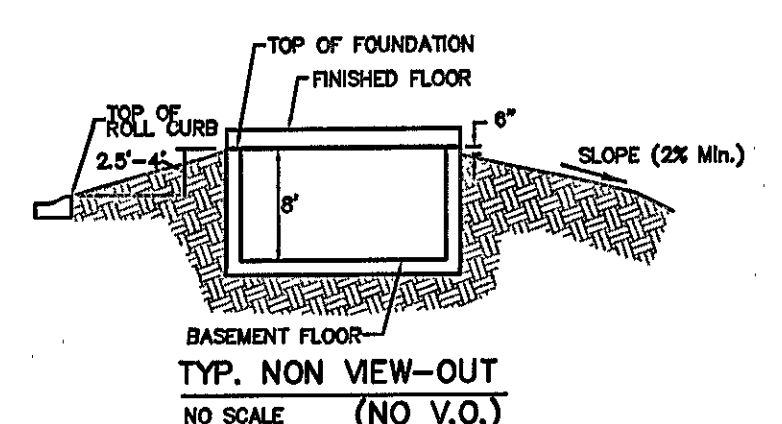
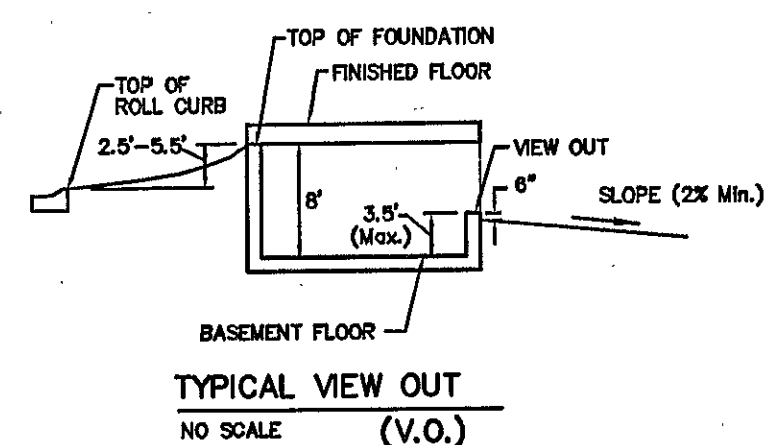

NOTE:
 Proposed top of foundation are shown on plans. Contractor to set finish floor elevation.
 All street elevations shown on plans are for top of curb (full height).
 View-out elevations are denoted as XX.X V.O.
 Walk-out elevations are denoted as XX.X W.O.
 CONTOUR INTERVAL = 1 FT.
 ● - Denotes the Possibility of Deep Foundations

MINIMUM BUILDING PAD ELEVATIONS FOR LOWEST OPENING TO THE STRUCTURES

LOT	BLOCK	ELEVATION CITY DATUM
5-12	B	140.7
13-19	B	140.9
20,21,34	B	141.0
35	B	142.0
36	B	142.5
37	B	143.0
38	B	143.5
39-41	B	144.0
42-44	B	144.2
45-47	B	144.7
48-50	B	145.0
51-53	B	145.2
54-57	B	145.5

BENCHMARK:
 119TH ST. W. & PANNEE
 CITY OF WICHITA BENCHMARK DISC
 NE CORNER OF INTERSECTION
 40.00' E. OF @
 30.00' N. OF @
 59.50' N. OF P.P. AT SE. COR. OF INTERSECTION
 156.80' NNE. OF @ OF E. CONC. HEADWALL ON CULVERT UNDER 119TH ST. W.
 ELEV. = 148.68 CITY DATUM (1336.08 NGVD25)
 (PER CITY RECORD)

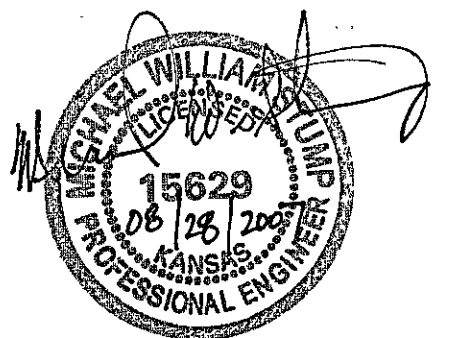

Rev. 8/28/07, T.F. & V.O. Phase 3 by MWS
 Rev. 2/14/07, T.F. & V.O. Lot 38, Block E by AEG

Baughman Turkey Creek 2nd Addition
Grading Plan
 City of Wichita, Kansas

Baughman Company, P.A. 315 Ellis St., Wichita, KS 67211 P 316-262-7771 F 316-262-7772
 ENGINEERING | SURVEYING | PLANNING | LANDSCAPE ARCHITECTURE

PROJECT NUMBER	DESIGN	DRAW
REVISIONS	BLG/MWS	MW
April 22, 2004	APPROVED	DATE
June 3, 2005		02/0
Revised T.F. and V.O. grades Phase 1 only	SCALE	Noted
4/12/06	MWS/JAK	SHEET
Revised T.F. and V.O. grades Phase 2		

3 OF 3

SCALE: 1" = 60'
 • = Iron

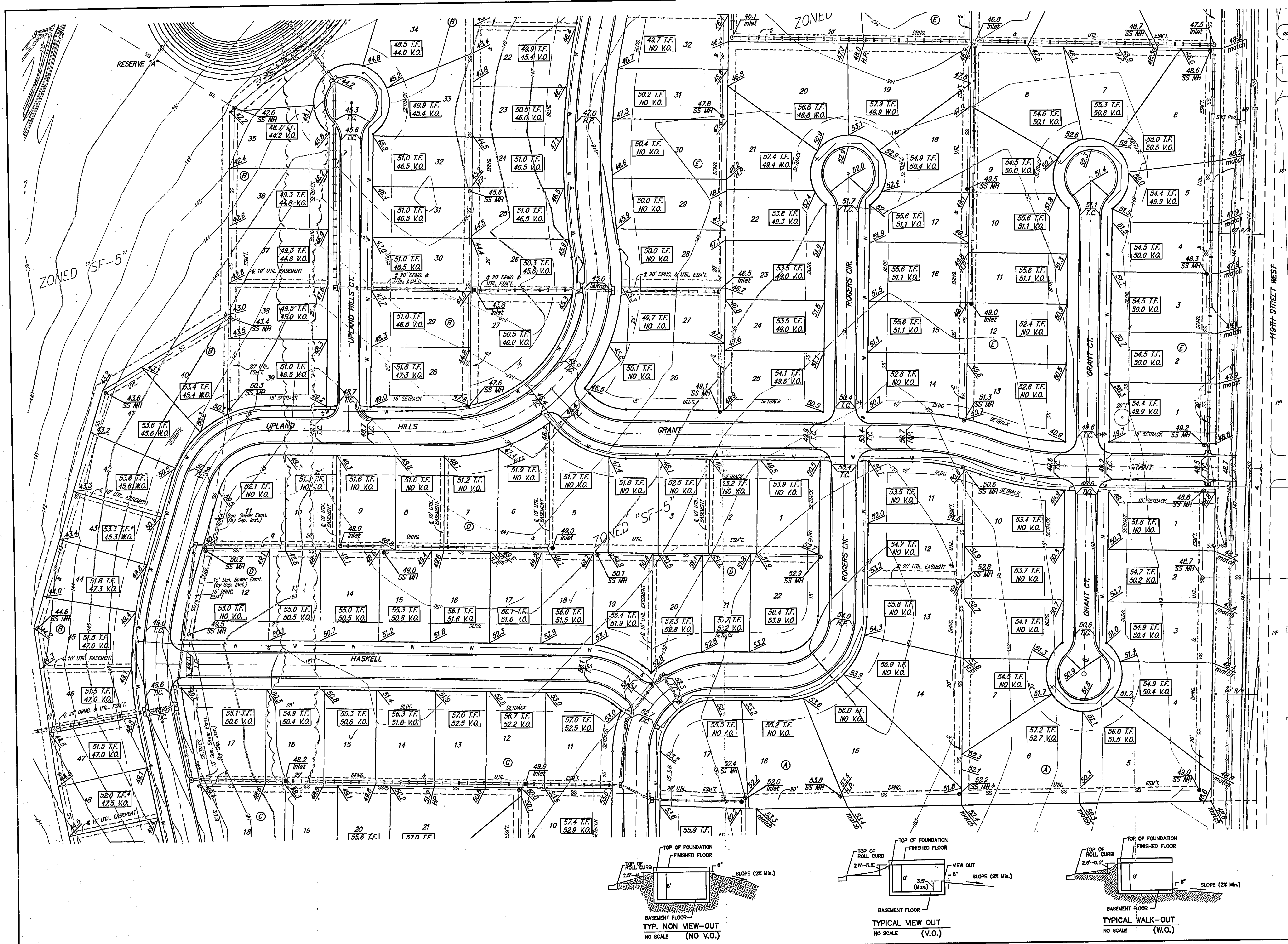

SCALE: 1" = 60'
 • = Iron

BENCHMARK:
 119TH ST. W. & PAWNEE
 CITY OF WICHITA BENCHMARK DISC
 NE. CORNER OF INTERSECTION
 40.00' E. OF E.
 30.00' N. OF E.
 59.50' N. OF P.P. AT SE. COR.
 OF INTERSECTION
 156.80' NNE. OF E. OF E. CONC.
 HEADWALL ON CULVERT
 UNDER 119TH ST. W.
 ELEV. = 148.68 CITY DATUM
 (1336.08 NGVD29)
 (PER CITY RECORD)

LOT	BLOCK	ELEVATION CITY DATUM
5-12	B	140.7
13-19	B	140.9
20,21,34	B	141.0
35	B	142.0
36	B	142.5
37	B	143.0
38	B	143.5
39-41	B	144.0
42-44	B	144.2
45-47	B	144.7
48-50	B	145.0
51-53	B	145.2
54-57	B	145.5



NOTE:
 Proposed top of foundation are shown on plans. Contractor to set finish floor elevation.
 All street elevations shown on plans are for top of curb (full height).
 View-out elevations are denoted as XX.X V.O.
 Walk-out elevations are denoted as XX.X W.O.
 CONTOUR INTERVAL = 1 FT.
 • - Denotes the Possibility of Deep Foundations

Rev. 8/26/07, T.F. & V.O. Phase 3 by MWS
 Rev. 2/14/07, T.F. & V.O. Lot 38, Block E by AEG

Baughman Grading Plan
 City of Wichita, Kansas

Baughman Company, P.A. 315 Ellis St. Wichita, KS 67211 P316762721 F3167
 ENGINEERING | SURVEYING | PLANNING | LANDSCAPE ARCHITECTURE

PROJECT NUMBER	DESIGN	DR
REVISIONS	BLG/MWS	M
APPROVED	APPROVED	DP
SCALE	Noted	02
SHEET		2 OF 3

REVISIONS:
 April 22, 2004 MWS
 Revised T.F. and V.O. grades
 June 3, 2005 MWS
 Revised T.F. and V.O. grades - Phase 1 only
 4/12/06 MWS/JAK
 Revised T.F. and V.O. grades Phase 2

FILE: G:\Grade\Turkey Creek\grade.dwg

