

UTILITY PLAN

THE HERITAGE AT AUBURN HILLS

AN ADDITION TO WICHITA, SEDGWICK COUNTY, KANSAS

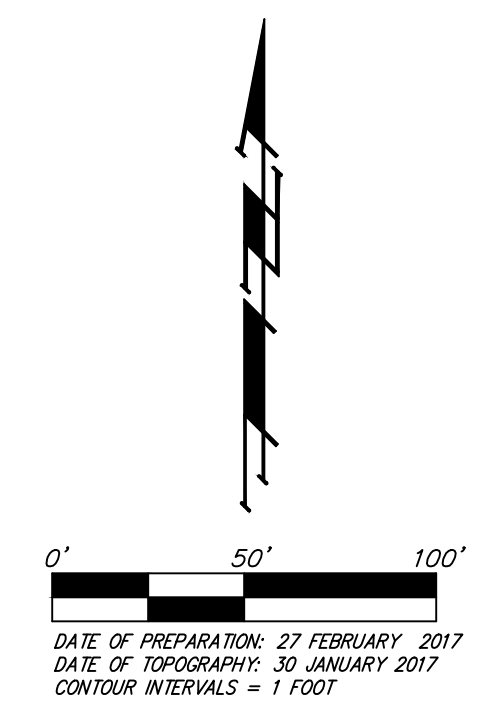
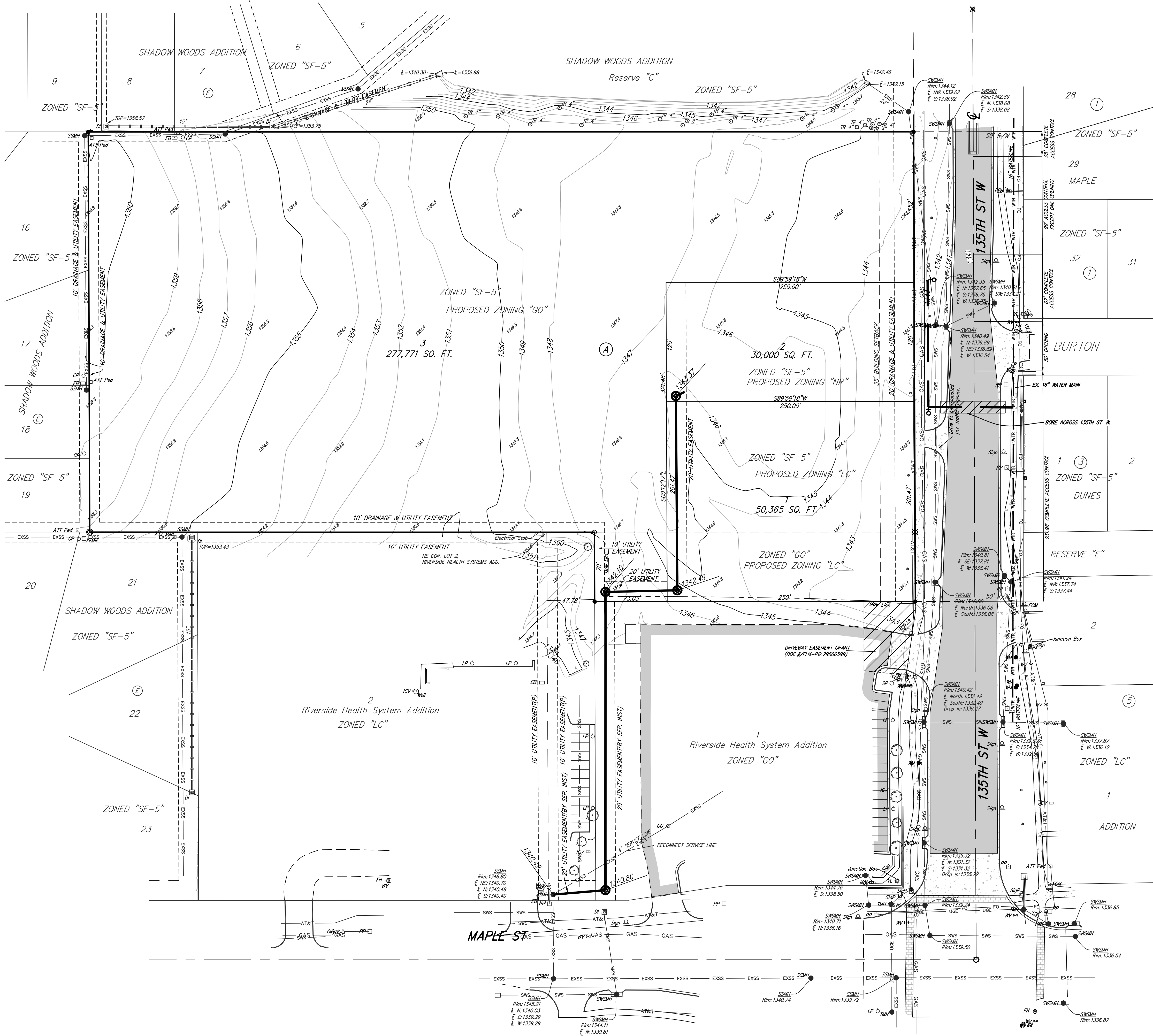

OWNER/DEVELOPER:
MAPLE 135, LLC
150 N. MARKET
WICHITA, KS 67202

LEGAL DESCRIPTION:
LOT 1, BLOCK F, SHADOW WOODS ADDITION,
WICHITA, SEDGWICK COUNTY, KANSAS.
TOGETHER WITH THE NORTH 70.00 FEET OF
LOT 1, EXCEPT THE WEST 47.78 FEET,
RIVERSIDE HEALTH SYSTEM ADDITION, WICHITA,
SEDGWICK COUNTY, KANSAS.

- BENCHMARK:**
CROSS CUT EAST EDGE OF SIDEWALK 60±
NORTH OF THE SE CORNER OF LOT 1, BLOCK A.
ELEV. = 1342.07 (NAVD88)
- = #4 Baughman Rebar Set
 - ⊗ = Chiseled "X" Set
 - = #4 Baughman Rebar Found
 - ⊙ = #4 "Savoy" Capped Rebar Found (Green Cap)
 - ⊚ = #4 Rebar Found (Origin Unknown)
 - ⊛ = 1/2" Iron Pipe Found (Monument Box)
 - ⊞ = #4 "Schwab-Eaton" Capped Rebar Found (Thimble)
 - ⊠ = Benchmark

- ATT Ped □ = AT&T Pedestal
- Well ○ = Cased Well
- CO ○ = Clean Out
- RI □ = Drop Inlet
- EB □ = Electric Box
- FH □ = Fire Hydrant
- FOW □ = Fiber Optics Marker
- Guy ⚓ = Guy Anchor
- IG ⚓ = Irrigation Control Valve
- LP ○ = Light Pole
- PP □ = Power Pole
- Sign ○ = Sign
- SP ○ = Signal Pole
- SSMH ● = Sanitary sewer Manhole
- SP ○ = Stand Pipe
- SSWH ● = Storm Water Sewer Manhole
- TM ● = Traffic Manhole
- Tree ○ = Tree
- CP ○ = Television Pedestal
- WV ● = Water Meter
- WV ● = Water Valve
- YL ⚓ = Yard Light

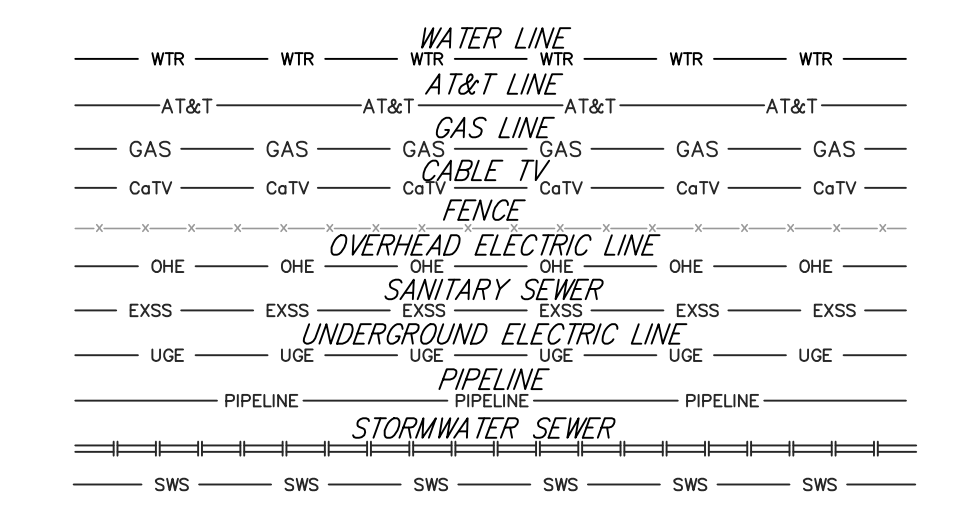
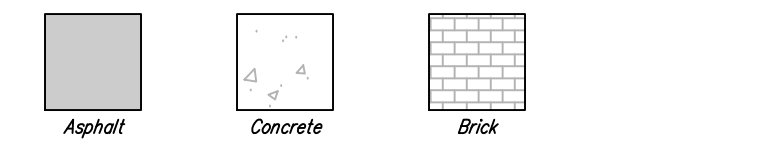

- LEGEND**
- Proposed Water Line (8" Unless Noted Otherwise)
 - Existing Water Line (8" Unless Noted Otherwise)
 - ♀ Proposed Fire Hydrant
 - ♀ Existing Fire Hydrant
 - Proposed Sanitary Sewer Line (8" Unless Noted Otherwise)
 - Existing Sanitary Sewer Line (8" Unless Noted Otherwise)
 - SSMH ● Existing Sanitary Sewer Manhole
 - ⊙ Proposed Sanitary Sewer Manhole
 - XXXXXX Proposed Sanitary Sewer Flow

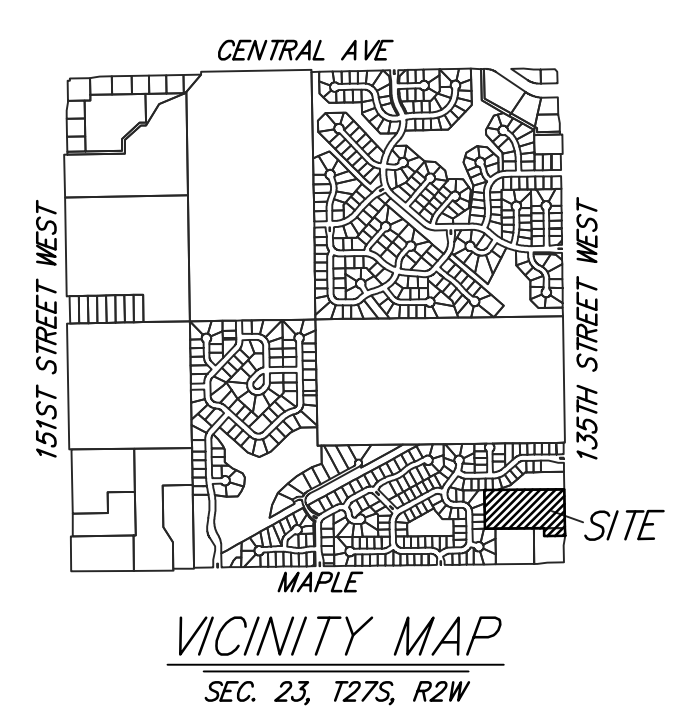

UTILITY PLAN
THE HERITAGE
AT AUBURN HILLS

27 February 2017

Baughman Company, P.A.
315 Ellis St. Wichita, KS 67211 P 316-262-7271 F 316-262-0149

ENGINEERING | SURVEYING | PLANNING | LANDSCAPE ARCHITECTURE