

Benchmarks

City of Wichita Disc at Southwest Corner of 135th St. W. & 13th St. N
 30.00'± S. of \odot
 35.00'± W. of \odot
 Elev. = 1355.65 NGVD29

Small Railroad Spike in 2nd HLP W. of 135th St. W. on South Side of 13th St. N., (N. Face of HLP).
 Elev. = 1359.50 NGVD29

Small Railroad Spike in 4th HLP W. of 135th St. W. on South Side of 13th St. N., (N. Face of HLP).
 Elev. = 1366.64 NGVD29

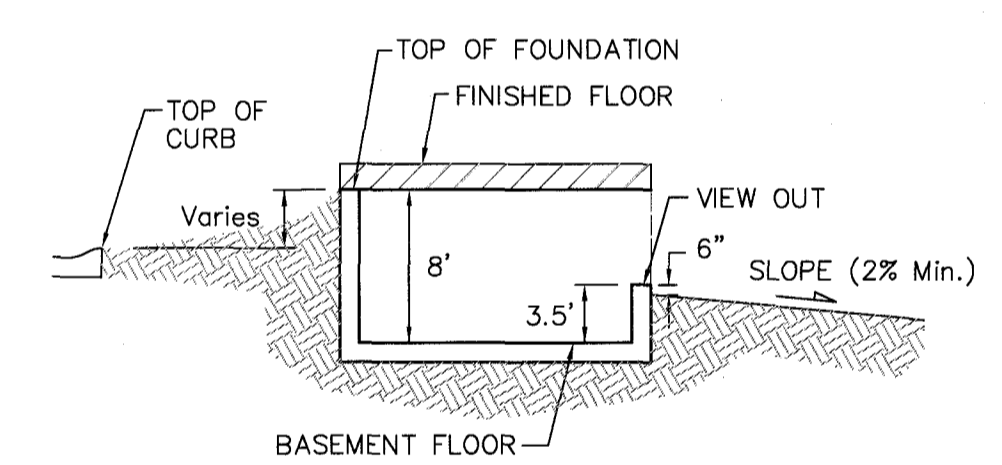
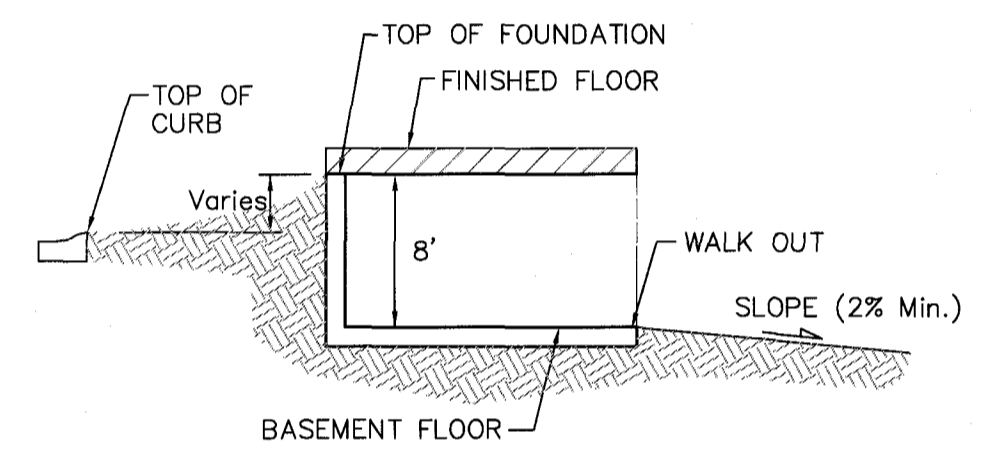
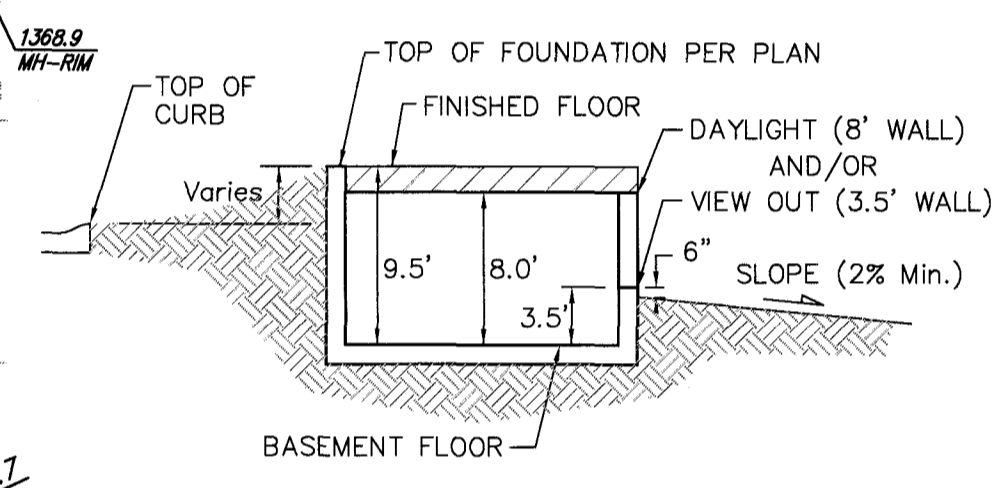
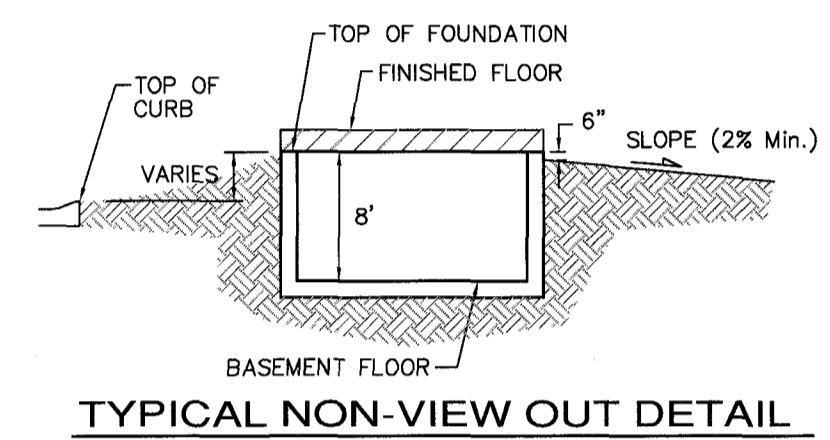

NOTES:
 Proposed Top of Foundation Elevations Are Shown On Plans. Contractor to Set Finished Floor Elevations.

All Street Elevations Shown on Plans Are for Top of Curb (Full-Height).

This Grading Plan is Designed with Walk-out & View-Out Basements. Elevations Shown as (XX.X V.O. or XX.X W.O.)

Lot dimensions have been omitted on this plan, refer to the recorded plat for this information.

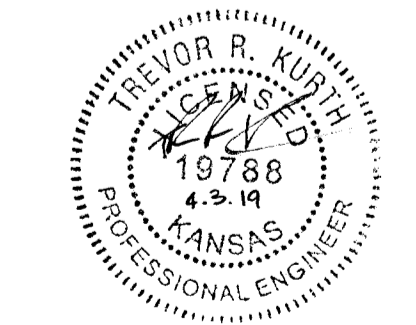

Deep Foundation May be Required

		Blackstone Addition Grading Plan City of Wichita, Kansas	
<small>Baughman Company, P.A. 315 Ellis St. Wichita, KS 67211 P 316.262.7271 F 316.262.6146 ENGINEERING SURVEYING PLANNING LANDSCAPE ARCHITECTURE</small>			
PROJECT NUMBER	DESIGN	DRAWN	APPROVED
REVISIONS: 2/20/19 4/03/19 Added viewouts and easements	JAK TRK/JAK	JAK	DATE 6/07
SCALE 1" = 60'		SHEET	
		3 OF 3	