

**BENCHMARKS:**  
 BM #1: City of Wichita disc top of headwall of RCBC 660± east of the SE Cor. of the SE1/4, SEC. 22, TWP. 27-S, R-2-W. Elev. = 1410.27 NAVD88

BM #2: 60d step nail in utility pole 28' east of & 162nd St. W. and 26' north of & of Maple. Elev. = 1417.99 NAVD88

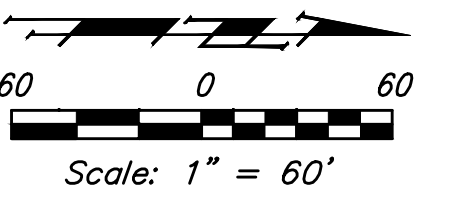

**NOTES:**

1. PROPOSED TOP OF FOUNDATION ELEVATIONS ARE SHOWN ON PLANS. CONTRACTOR TO SET FINISHED FLOOR AND GARAGE FLOOR ELEVATIONS. ALL STREET ELEVATIONS SHOWN ON PLANS ARE FOR TOP OF CURB (FULL-HEIGHT).
2. ALL LOTS SHALL MEET OR EXCEED MINIMUM PAD REQUIREMENT AS SHOWN ON THE RECORDED PLAT.
3. LOT DIMENSIONS HAVE BEEN OMITTED ON THIS PLAN. REFER TO THE RECORDED PLAT FOR FINAL DIMENSION, EASEMENT, & BUILDING SETBACK INFORMATION.
4. A DRAINAGE PLAN HAS BEEN DEVELOPED FOR THIS SUBDIVISION AND IS ON FILE WITH THE CITY OF WICHITA, KANSAS. DRAINAGE INTENT SHALL REMAIN AS DEPICTED OR AS MODIFIED WITH THE APPROVAL OF THE CITY ENGINEER OF THE CITY OF WICHITA, KANSAS. NO OBSTRUCTIONS WHICH IMPEDED THE FLOW OF THIS DRAINAGE PLAN SHALL BE ALLOWED.
5. ALL ELEVATIONS SHOWN ARE NAVD88 DATUM.

**LEGEND:**

- Flow Arrow
- - - Existing Ground Contour
- Extra Deep Foundations may be required
- T.F. Top of Foundation
- V.O. View-out Basement
- W.O. Walk-out Basement
- No V.O. Non View-out Basement
- SLAB Concrete Floor Slab, No Basement

LOT	BLOCK	ELEVATION NAVD88
1-12,14,15	B	1414.0
55,56,69,90,91	D	1418.0
1,10	E	1417.5
11,21,22,34,35	E	1424.0

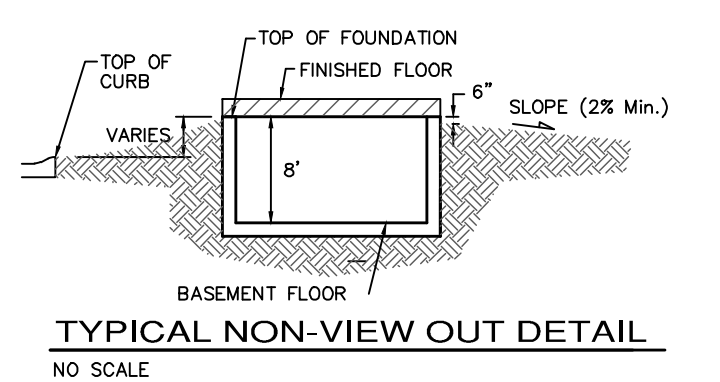
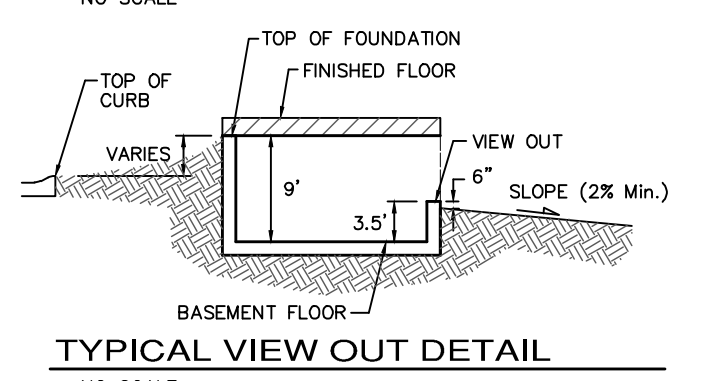
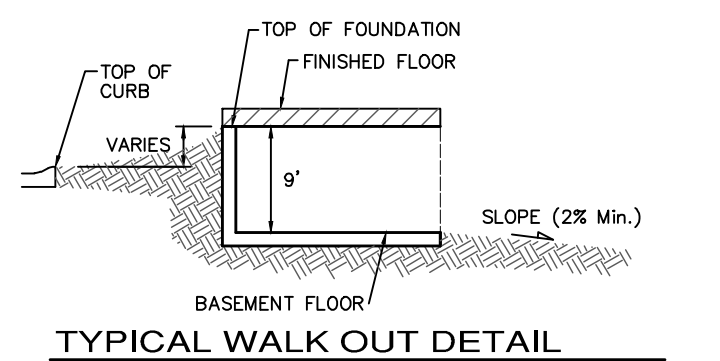

**Baughman** Pike Addition  
**GRADING PLAN**  
 Wichita, Kansas

Baughman Company, P.A. 315 Ellis St. Wichita, KS 67211 P 316-262-7271 F 316-262-0149  
 ENGINEERING | SURVEYING | PLANNING | LANDSCAPE ARCHITECTURE

PROJECT NUMBER	DESIGN AEG	DRAWN TMS
REVISIONS:	APPROVED DATE 10/19	SHEET 4 OF 5

E:\Projects\Pike Addition, Engineering\PRE\_GRADE.dwg

**PRELIMINARY**

