

VICINITY MAP

LEGEND

- ⊙ - CONIFEROUS TREE & DIAMETER
- ⊙ - DECIDUOUS TREE & DIAMETER
- ⊙ - SIGN
- ⊙ - BUSH
- - EDGE OF TREES
- - FENCE
- ⊙ - SANITARY SEWER MANHOLE
- ⊙ - GAS METER
- ⊙ - POLE
- ⊙ - HIGH LINE POLE
- ⊙ - GATE
- ⊙ - LIGHT POLE
- ⊙ - FIRE HYDRANT
- ⊙ - WATER VALVE
- ⊙ - WATER METER
- ⊙ - POWER POLE AND GUY ANCHOR
- ⊙ - TELEPHONE RISER
- ⊙ - INLET
- - STORM SEWER PIPE
- - WATER LINE
- - SANITARY SEWER LINE
- - GAS LINE
- - TELEPHONE LINE
- - UNDERGROUND ELECTRIC LINE
- - OVERHEAD TELEPHONE
- - OVERHEAD ELECTRIC
- - UNDERGROUND FIBER OPTIC CABLE
- ⊙ - SECTION CORNER
- ⊙ - PROPERTY CORNER FOUND
- ⊙ - BENCHMARK
- WO - WALK OUT
- VO - VIEW OUT
- PVO - PARTIAL VIEW OUT
- PWO - PARTIAL WALK OUT
- NVO - NO VIEW OUT

BENCHMARKS

- BM#4 RR Spike in W face of South H-pole East of Tyler Rd, 3320 N Tyler Rd Elev. = 175.53
- BM#5 RR Spike in S face of S H-pole 3rd H-poles West of Tyler Rd, and 1/2 mile N of 29th St N. Elev. = 169.24

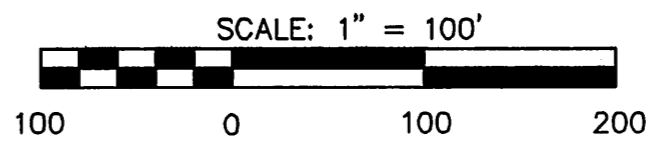

MINIMUM PAD ELEVATIONS (LOWEST OPENINGS)				
LOTS	BLOCK	ELEVATION (CITY DATUM)	ELEVATION (NGVD)	HGL (CITY DATUM)
102	1	167.8	1355.2	165.8
103	1	167.8	1355.2	165.8
104	1	N/A	N/A	166.3
105	1	N/A	N/A	166.3
106	1	167.8	1355.2	165.8
107	1	167.8	1355.2	165.8
108	1	167.8	1355.2	165.8
109	1	167.8	1355.2	165.8
110	1	167.8	1355.2	165.8
111	1	167.8	1355.2	165.8
112	1	167.8	1355.2	165.8
113	1	167.8	1355.2	165.8
114	1	167.8	1355.2	165.2
115	1	N/A	N/A	165.2
116	1	N/A	N/A	165.3
117	1	N/A	N/A	165.6
118	1	N/A	N/A	166.1
119	1	N/A	N/A	166.1
120	1	N/A	N/A	165.8
121	1	N/A	N/A	165.6
122	1	N/A	N/A	165.3
123	1	N/A	N/A	165.2
124	1	167.8	1355.2	165.2
125	1	167.8	1355.2	165.3
126	1	N/A	N/A	165.3
127	1	N/A	N/A	165.5
128	1	N/A	N/A	165.8

MINIMUM PAD ELEVATIONS (LOWEST OPENINGS)				
LOTS	BLOCK	ELEVATION (CITY DATUM)	ELEVATION (NGVD)	HGL (CITY DATUM)
129	1	N/A	N/A	166.3
130	1	N/A	N/A	166.3
131	1	N/A	N/A	165.8
132	1	N/A	N/A	165.5
133	1	N/A	N/A	165.3
134	1	167.6	1355.0	165.3
135	1	167.1	1354.5	165.0
136	1	167.1	1354.5	165.0
137	1	167.1	1354.5	165.0
138	1	167.1	1354.5	165.0
139	1	167.1	1354.5	165.0
140	1	167.1	1354.5	165.0
141	1	167.1	1354.5	165.0
142	1	167.1	1354.5	165.0
143	1	167.1	1354.5	165.0
144	1	167.1	1354.5	165.0
145	1	167.1	1354.5	165.0
146	1	167.1	1354.5	166.1
1	3	N/A	N/A	166.6
2	3	N/A	N/A	166.6
3	3	N/A	N/A	166.7
4	3	N/A	N/A	166.9
5	3	N/A	N/A	166.9
6	3	N/A	N/A	166.7
7	3	N/A	N/A	166.6
8	3	N/A	N/A	166.6

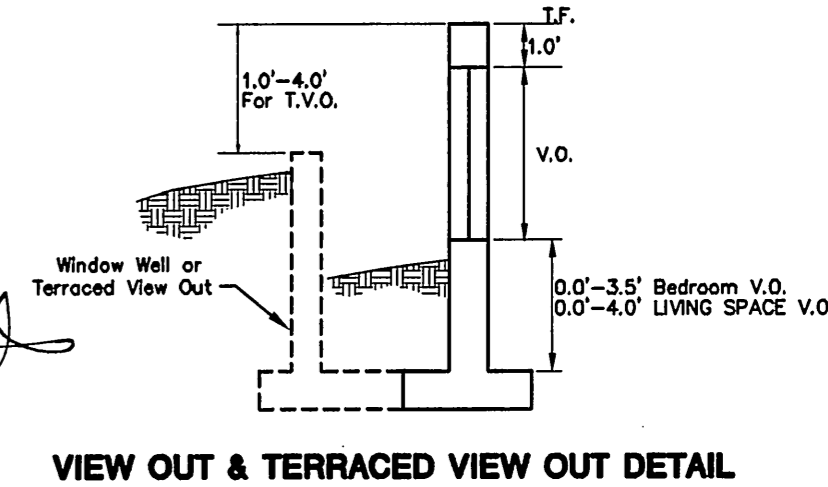

VIEW OUT & TERRACED VIEW OUT DETAIL

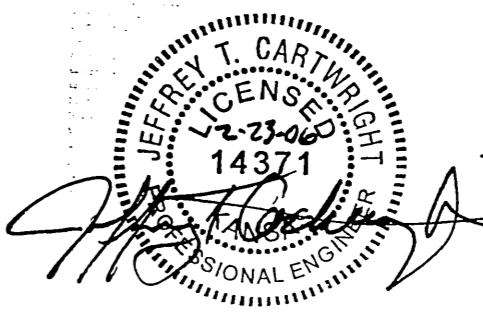

MKEC
ENGINEERING CONSULTANTS, INC.

FOX RIDGE ADDITION
PROJECT NAME

PHASE 4 - VIEWOUT/WALKOUT MAP
SHEET TITLE

411 N. WEBB ROAD
WICHITA, KS. 67206
316-684-9600

DESIGN BY: KLA
DRAWN BY: JWC/SMD/JFL
CHECKED BY: GJA

DATE: FEBRUARY 2006
JOB NO.: 99118
SHEET/OF: 1 / 2

G:\CIVIL\99118\DWG\GRAD\LOT GRADING PLANS 99118_V0-WO_MAP-PHASE4.DWG