

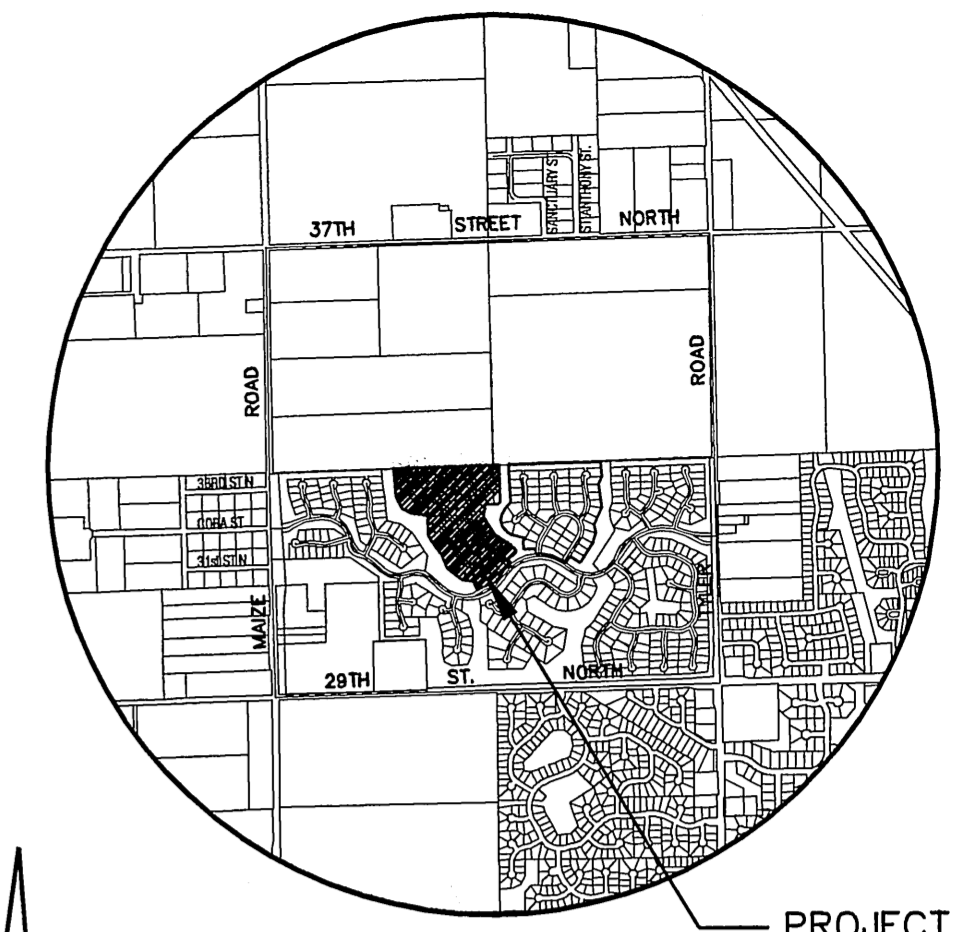

**MINIMUM PAD ELEVATIONS
(LOWEST OPENINGS)**

LOTS	BLOCK	ELEVATION		HGL (CITY DATUM)
		(CITY DATUM)	(NGVD)	
46	1	166.2	1353.6	N/A
47	1	166.2	1353.6	N/A
48	1	166.2	1353.6	N/A
49	1	166.2	1353.6	N/A
50	1	166.2	1353.6	N/A
51	1	166.2	1353.6	N/A
52	1	166.2	1353.6	N/A
53	1	166.2	1353.6	N/A
54	1	166.2	1353.6	N/A
55	1	166.2	1353.6	N/A
56	1	166.2	1353.6	N/A
57	1	166.2	1353.6	N/A
58	1	166.2	1353.6	N/A
59	1	166.2	1353.6	N/A
60	1	166.2	1353.6	N/A
61	1	166.2	1353.6	N/A
62	1	166.2	1353.6	N/A
63	1	166.2	1353.6	N/A
64	1	166.2	1353.6	N/A
65	1	166.2	1353.6	N/A
66	1	166.2	1353.6	N/A
67	1	166.2	1353.6	N/A
68	1	166.2	1353.6	N/A
69	1	N/A	N/A	166.5
70	1	N/A	N/A	166.5
71	1	N/A	N/A	166.5
72	1	N/A	N/A	166.5
73	1	166.6	1354.0	N/A
74	1	167.1	1354.5	N/A
75	1	N/A	N/A	166.8
76	1	N/A	N/A	167.0
77	1	N/A	N/A	167.0
78	1	N/A	N/A	167.1
79	1	N/A	N/A	167.1
80	1	N/A	N/A	167.1
81	1	N/A	N/A	167.1
82	1	N/A	N/A	167.0
83	1	N/A	N/A	167.0
84	1	N/A	N/A	166.8
85	1	167.8	1355.2	N/A
86	1	167.8	1355.2	N/A
87	1	N/A	N/A	168.0
88	1	167.8	1355.2	N/A
89	1	167.8	1355.2	N/A
90	1	167.8	1355.2	N/A
91	1	167.8	1355.2	N/A
92	1	167.8	1355.2	N/A
93	1	167.8	1355.2	N/A
94	1	167.8	1355.2	N/A
95	1	167.8	1355.2	N/A
96	1	167.8	1355.2	N/A
97	1	167.8	1355.2	N/A
98	1	167.8	1355.2	N/A
99	1	167.8	1355.2	N/A
100	1	167.8	1355.2	N/A
101	1	167.8	1355.2	N/A
1	2	N/A	N/A	167.1
2	2	N/A	N/A	166.9
3	2	N/A	N/A	166.8
4	2	N/A	N/A	166.8
5	2	N/A	N/A	166.8
6	2	N/A	N/A	166.8
7	2	N/A	N/A	166.8
8	2	N/A	N/A	166.8
9	2	N/A	N/A	166.8
10	2	N/A	N/A	166.9
11	2	N/A	N/A	167.1
12	2	N/A	N/A	167.1



VICINITY MAP

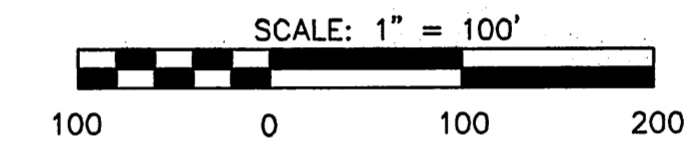

BENCHMARKS

- BM#1 C.O.W. disc 0.5 miles east of Maize Rd. on 29th St. No. + 25' north of 29th St. Cl. Elev.=160.86
- BM#2 C.O.W. disc north side of Den Hollow @ P.C. between Lots 44 & 43, Blk. 4 Elev.=166.40

LEGEND

- 6IN - CONIFEROUS TREE & DIAMETER
- 3IN - DECIDUOUS TREE & DIAMETER
- SM - SIGN
- BUSH
- EDGE OF TREES
- FENCE
- SSMH - SANITARY SEWER MANHOLE
- GM - GAS METER
- POLE - POLE
- HLP - HIGH LINE POLE
- LP - LIGHT POLE
- FH - FIRE HYDRANT
- WV - WATER VALVE
- WM - WATER METER
- PPA - POWER POLE AND GUY ANCHOR
- TR - TELEPHONE RISER
- INLET
- DRAINAGE ESCAPE ROUTE
- PAD=162.8 ADD 2 STEPS TF=164.8 V=162.8 MP=162.8
- PAD=172.4 ADD 1 STEP TF=172.4 V=168.2 MP=168.2
- STORM SEWER PIPE
- WATER LINE
- SANITARY SEWER LINE
- GAS LINE
- TELEPHONE LINE
- UNDERGROUND ELECTRIC LINE
- OVERHEAD TELEPHONE
- OVERHEAD ELECTRIC
- UNDERGROUND FIBER OPTIC CABLE
- SECTION CORNER
- PROPERTY CORNER FOUND
- BENCHMARK
- WALK OUT
- VIEW OUT
- PARTIAL VIEW OUT
- PARTIAL WALK OUT
- NO VIEW OUT
- FLOW ARROW

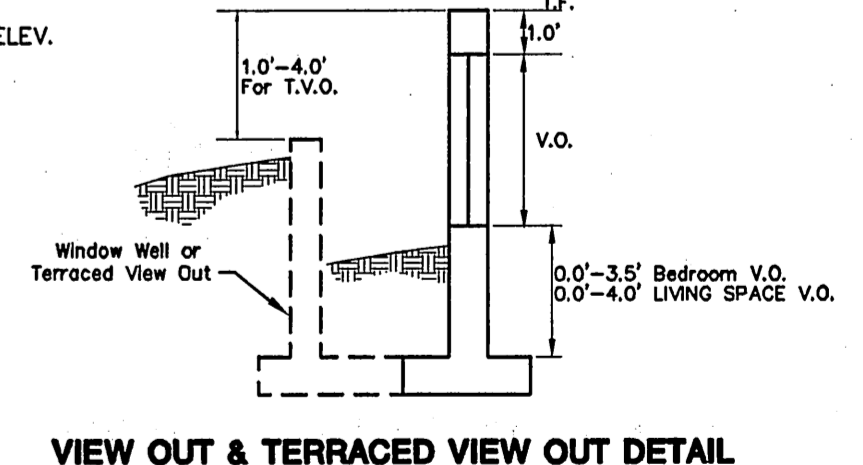

Revision Date:

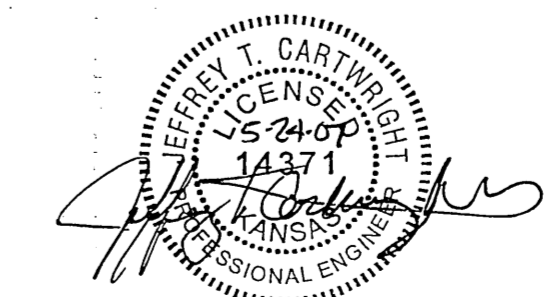

MKEC **FOX RIDGE ADDITION**
 ENGINEERING **PHASE 5 - VIEWOUT/WALKOUT MAP**
 CONSULTANTS, INC. **PENNYCRESS**

411 N. WEBB ROAD WICHITA, KS. 67206 316-684-9600	KLA DESIGN BY:	JWC DRAWN BY:	GJA CHECKED BY:
MAY 2007 DATE	99118 JOB NO.	1 / 1 SHEET/OF	

G:\CIVIL\99118\DWG\GRAD\LOT GRADING PLANS\99118_VO_WO_MAP-PHASE5.DWG