

BENCHMARKS:
 RR Spike in N. Face of PP in N.
 R/W of Maple N. of Nineiron.
 Elev. = 177.01 (City Datum)

"□" Cut center of north Headwall
 of RCBC in N. R/W of Maple 570'
 East of centerline of City View.
 Elev. = 187.91 (City Datum)

Scale: 1" = 60'

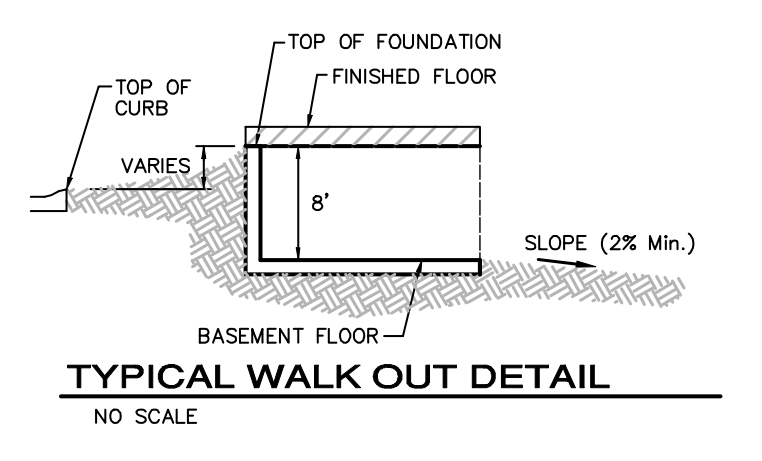
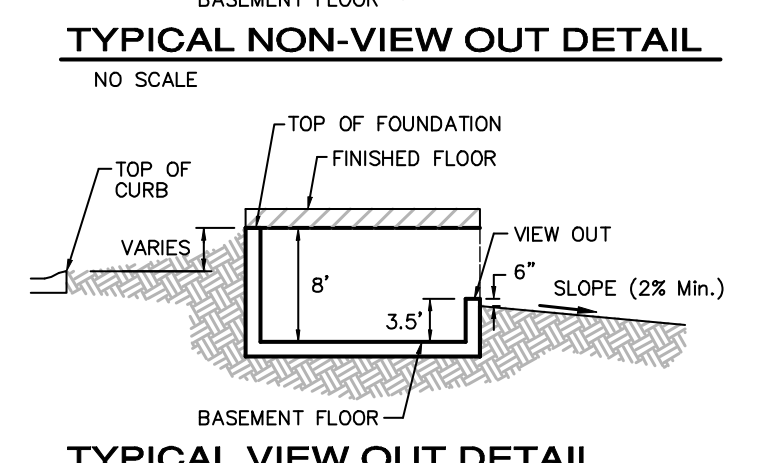
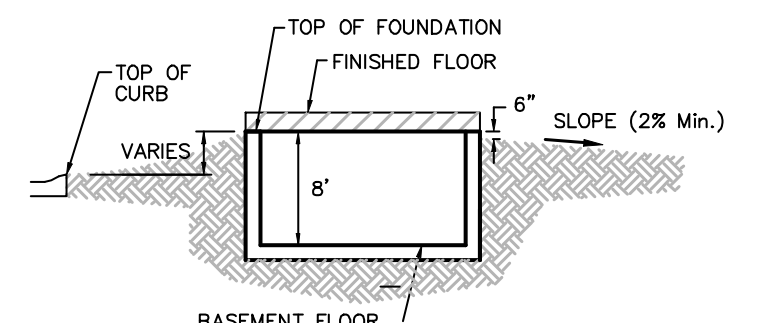

- NOTES:**
- PROPOSED TOP OF FOUNDATION ELEVATIONS ARE SHOWN ON PLANS. CONTRACTOR TO SET FINISHED FLOOR AND GARAGE FLOOR ELEVATIONS. ALL STREET ELEVATIONS SHOWN ON PLANS ARE FOR TOP OF CURB (FULL-HEIGHT).
 - THIS GRADING PLAN IS DESIGNED WITH VIEW-OUTS AND WALK-OUTS. ELEVATIONS SHOWN AS XX.X V.O. DEPICT VIEW-OUT STRUCTURES. ELEVATIONS SHOWN AS XX.X W.O. DEPICT WALK-OUT STRUCTURES.
 - ALL LOTS SHALL MEET MINIMUM PAD REQUIREMENT AS SHOWN ON THE RECORDED PLAT.

MINIMUM BUILDING PAD ELEVATIONS FOR LOWEST OPENING TO THE STRUCTURES			
LOT	BLOCK	CITY DATUM	ELEVATION
1-24	D	177.20	1364.60
1-7	E	160.50	1347.90

- LOT DIMENSIONS HAVE BEEN OMITTED ON THIS PLAN. REFER TO THE RECORDED PLAT FOR FINAL DIMENSION, EASEMENT, & BUILDING SETBACK INFORMATION.
- HOUSE PAD ELEVATIONS DEPICTED WITH BOLD OUTLINES WITH TOP OF FOUNDATIONS SHOWN AS XX.X T.F.* INDICATE THAT DEEP FOOTINGS OR DEEP FOUNDATIONS MAY BE REQUIRED.
- A DRAINAGE PLAN HAS BEEN DEVELOPED FOR THIS SUBDIVISION AND IS ON FILE WITH THE CITY OF WICHITA, KANSAS. DRAINAGE INTENT SHALL REMAIN AS DEPICTED OR AS MODIFIED WITH THE APPROVAL OF THE CITY ENGINEER OF THE CITY OF WICHITA, KANSAS. NO OBSTRUCTIONS WHICH IMPEDE THE FLOW OF THIS DRAINAGE PLAN SHALL BE ALLOWED.
- ALL ELEVATIONS SHOWN ARE CITY OF WICHITA DATUM.

SHADOW WOODS ADDITION
MASTER GRADING PLAN
 WICHITA, KANSAS

BAUGHMAN COMPANY P.A.
 ENGINEERING, SURVEYING, & PLANNING
 316-262-7271 • 315 ELLIS • WICHITA, KANSAS 67211

DESIGN	DRAWN	APPROVED	DATE	SCALE	SHEET
	SCL		03/13/03	NOTE	4

PROJECT NUMBER _____

REVISED PH. 5 GRADES TO FINAL BY WEB PER AEG 11/3/06
 REVISED SE CORNER GRADE LOT 17, D BY MAM PER AG 12-14-05
 REVISED PH. 1 GRADES FINALIZED 10/15/04 BY AEG
 REVISED NORTH P.L. & ESM'T GRADES 7/15/03 BY SMD PER AEG
 REVISED PH. 2 GRADES FINALIZED 12/14/04 BY AEG
 REVISED PH. 3 GRADES FINALIZED 8/18/05 BY AEG
 REVISED SOUTH R/W GRADES 6/25/03 BY AEG