

BENCHMARK:
600 nail step benchmark in high line pole
40 feet southwest of the Southeast
corner of Section 12-T-27-S-R-2-E
(N.G.I.D.=1347103)

- NOTES:
1. PROPOSED TOP OF FOUNDATION ELEVATIONS ARE SHOWN ON PLANS. CONTRACTOR TO SET FINISHED FLOOR AND GARAGE FLOOR ELEVATIONS. ALL STREET ELEVATIONS SHOWN ON PLANS ARE FOR TOP OF CURB (FULL-HEIGHT).
 2. THIS GRADING PLAN IS DESIGNED WITH WALK-OUTS AND WALK-OUTS. ELEVATIONS SHOWN AS XX.X V.O. DEPICT WALK-OUT STRUCTURES. ELEVATIONS SHOWN AS XXX W.O. DEPICT WALK-OUT STRUCTURES.
 3. ALL LOTS SHALL MEET MINIMUM PAD REQUIREMENT AS SHOWN ON THE RECORDED PLAT.

MINIMUM BUILDING PAD ELEVATIONS FOR LOWEST OPENING TO THE STRUCTURES			
LOT	BLOCK	ELEVATION	
1-3	A	1337.0	
9-15	A	1339.0	
1-5, 30-34	D	1342.0	
6-21, 26-29	D	1344.0	
13-20	F	1337.0	

4. LOT DIMENSIONS HAVE BEEN OMITTED ON THIS PLAN. REFER TO THE RECORDED PLAT FOR FINAL DIMENSION, EASEMENT, & BUILDING SETBACK INFORMATION.
5. HOUSE PAD ELEVATIONS DEPICTED WITH BOLD OUTLINES AND NOTED WITH THIS SYMBOL. * INDICATE THAT DEEP FOOTINGS OR DEEP FOUNDATIONS MAY BE REQUIRED.
6. A DRAINAGE PLAN HAS BEEN DEVELOPED FOR THIS SUBDIVISION AND IS ON FILE WITH THE CITY OF WICHITA, KANSAS. DRAINAGE INTENT SHALL REMAIN AS DEPICTED OR AS MODIFIED WITH THE APPROVAL OF THE CITY ENGINEER OF THE CITY OF WICHITA, KANSAS. NO OBSTRUCTIONS WHICH IMPED THE FLOW OF THIS DRAINAGE PLAN SHALL BE ALLOWED.
7. NO BUILDING PERMITS ARE TO BE ISSUED FOR ANY LOTS THAT ARE LOCATED IN THE SPECIAL FLOOD HAZARD AREA WITHIN THIS PLATTED SUBDIVISION UNLESS ONE OF THE FOLLOWING CONDITIONS ARE MET:
 - A. THE LOWEST FLOOR (INCLUDING BASEMENT) IS CONSTRUCTED A MINIMUM OF 1 FOOT ABOVE THE DETERMINED BASE FLOOD ELEVATION.
 - OR
 - B. A LETTER OF MAP REVISION (LOMR) IS ISSUED BY THE FEDERAL EMERGENCY MANAGEMENT AGENCY (FEMA) REMOVING THE SUBJECT PROPERTY FROM THE THE SPECIAL FLOOD HAZARD AREA WHICH WOULD THEN ALLOW BUILDINGS TO BE CONSTRUCTED WITH THE LOWEST OPENING AS SPECIFIED ON THIS GRADING PLAN AND MEETING FEMA TECHNICAL BULLETIN 10-01.
8. ALL LOTS LISTED BELOW SHALL MEET THE CONDITIONS SPECIFIED IN FEMA TECHNICAL BULLETIN 10-01.

PRELIMINARY PLAN
NOT FOR CONSTRUCTION

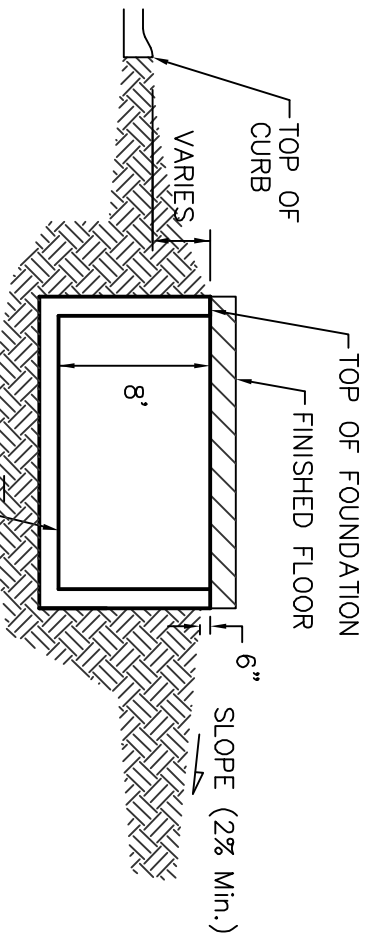

TYPICAL NON-VIEW OUT DETAIL
NO SCALE

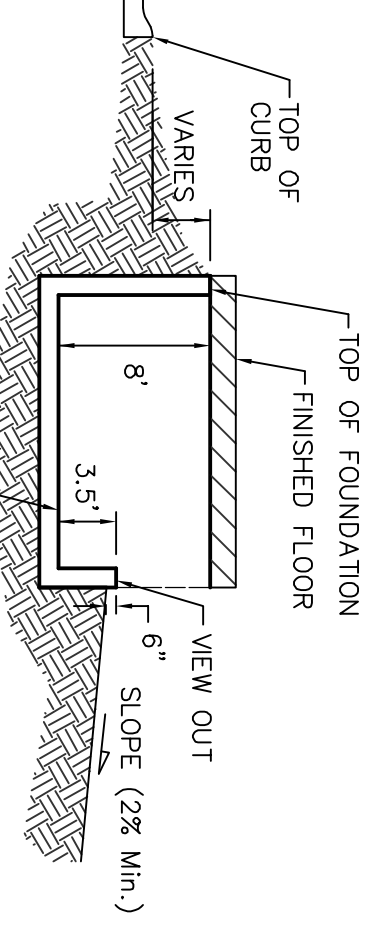

TYPICAL VIEW OUT DETAIL
NO SCALE

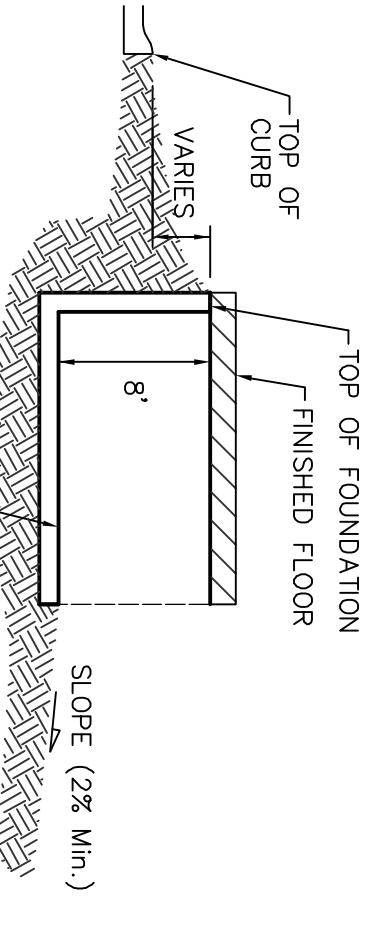

TYPICAL WALK OUT DETAIL
NO SCALE

NOTE: FEMA Floodplain boundary scaled per location per FEMA FIRM 200321 0150A.

	STONEBRIDGE 2ND	
	GRADING PLAN	
Baughman Company, P.A. 315 EHS, St. Vincent, KS 67271 P. 316.826.2721 F. 316.826.4049 ENGINEERING SURVEYING PLANNING LANDSCAPE ARCHITECTURE	DESIGN: B.L.G./TRK DRAWN: B.L.G./TRK DATE: 12/12/06 APPROVED:	SCALE: NOTED SHEET: 3 OF 3