

Pond data:
 Static ws elev. = 132.0
 100-yr ws elev. is
 Variable along reach

SCALE: 1" = 60'
 • = Iron

BENCHMARK:
 119TH ST. W. & PAWNEE
 CITY OF WICHITA BENCHMARK DISC
 NE. CORNER OF INTERSECTION
 40.00' E. OF @
 30.00' N. OF @
 59.50' N. OF P.P. AT SE. COR.
 OF INTERSECTION
 156.80' NNE. OF @ OF E. CONC.
 HEADWALL ON CULVERT
 UNDER 119TH ST. W.
 ELEV. = 148.68 CITY DATUM
 (1,336.08 NGVD29)
 (PER CITY RECORD)

LOT	BLOCK	ELEVATION
		CITY DATUM
5-12	B	140.7
13-19	B	140.9
20,21,34	B	141.0
35	B	142.0
36	B	142.5
37	B	143.0
38	B	143.5
39-41	B	144.0
42-44	B	144.2
45-47	B	144.7
48-50	B	145.0
51-53	B	145.2
54-57	B	145.5

NOTE:
 Proposed top of foundation are shown on plans. Contractor to set finish floor elevation.
 All street elevations shown on plans are for top of curb (full height).
 View-out elevations are denoted as XX.X V.O.
 Walk-out elevations are denoted as XX.X W.O.
 CONTOUR INTERVAL = 1 FT.
 • - Denotes the Possibility of Deep Foundations

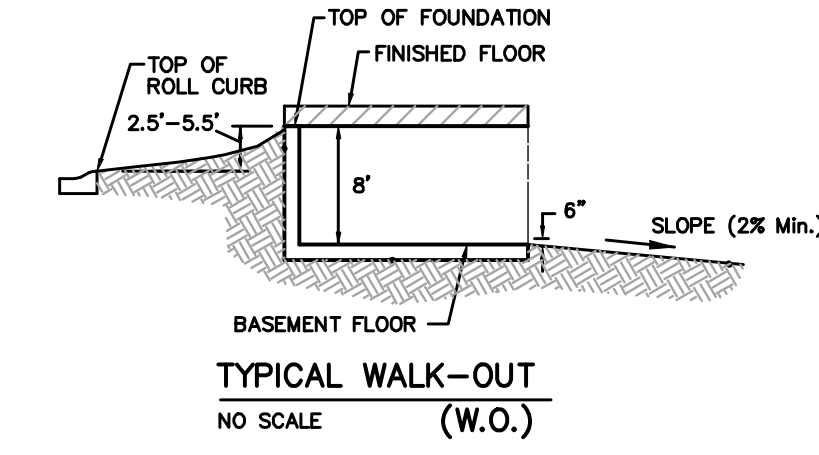
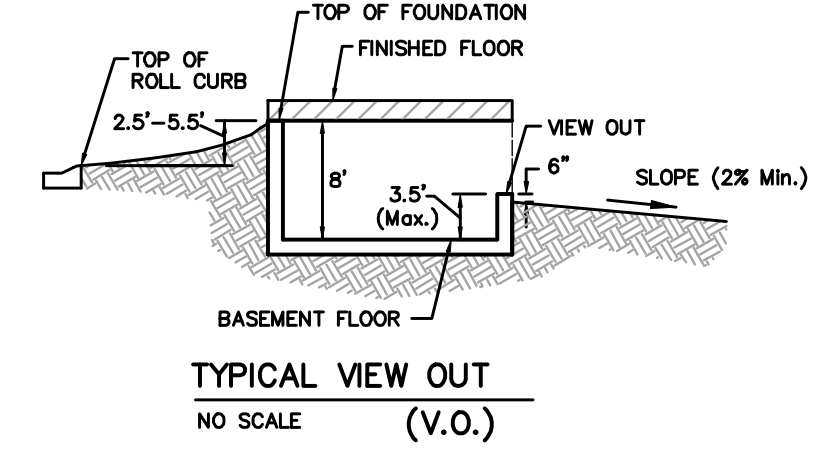
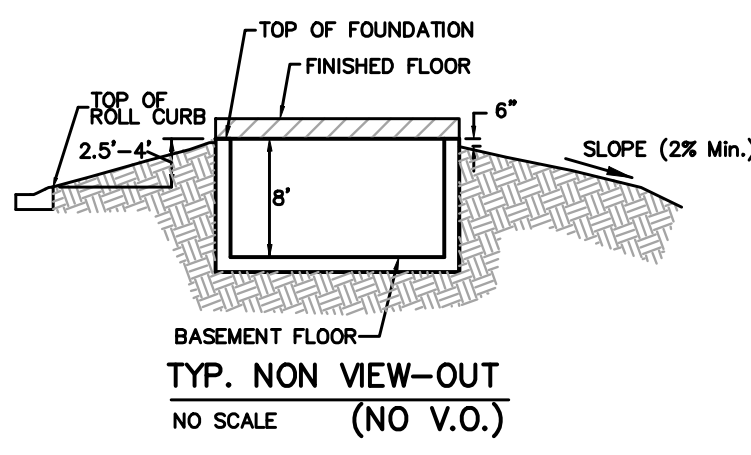

Baughman Turkey Creek 2nd Addition
Grading Plan
 City of Wichita, Kansas

Baughman Company, P.A. 315 Ellis St. Wichita, KS 67211 P 316-262-7271 F 316-262-0149
 ENGINEERING | SURVEYING | PLANNING | LANDSCAPE ARCHITECTURE

PROJECT NUMBER	DESIGN	DRAWN
	BLG/MWS	MWS
REVISIONS:	APPROVED	DATE
April 22, 2004	MWS	02/04
June 3, 2005	MWS	
4/12/06	MWS/JAK	

SCALE: Noted
 SHEET: 1 OF 3

F:\Grading\Turkey Creek\grdcd.dwg