

SCALE: 1" = 60'  
• = Iron

BENCHMARK:  
119TH ST. W. & PAWNEE  
CITY OF WICHITA BENCHMARK DISC  
NE. CORNER OF INTERSECTION  
40.00' E. OF @  
30.00' N. OF @  
59.50' N. OF P.P. AT SE. COR.  
OF INTERSECTION  
156.80' NNE. OF @ OF E. CONC.  
HEADWALL ON CULVERT  
UNDER 119TH ST. W.  
ELEV. = 148.68 CITY DATUM  
(1336.08 NGVD29)  
(PER CITY RECORD)

LOT	BLOCK	ELEVATION CITY DATUM
5-12	B	140.7
13-19	B	140.9
20,21,34	B	141.0
35	B	142.0
36	B	142.5
37	B	143.0
38	B	143.5
39-41	B	144.0
42-44	B	144.2
45-47	B	144.7
48-50	B	145.0
51-53	B	145.2
54-57	B	145.5

NOTE:  
Proposed top of foundation are shown on plans. Contractor to set finish floor elevation.  
All street elevations shown on plans are for top of curb (full height).  
View-out elevations are denoted as XX.X V.O.  
Walk-out elevations are denoted as XX.X W.O.  
CONTOUR INTERVAL = 1 FT.  
● - Denotes the Possibility of Deep Foundations

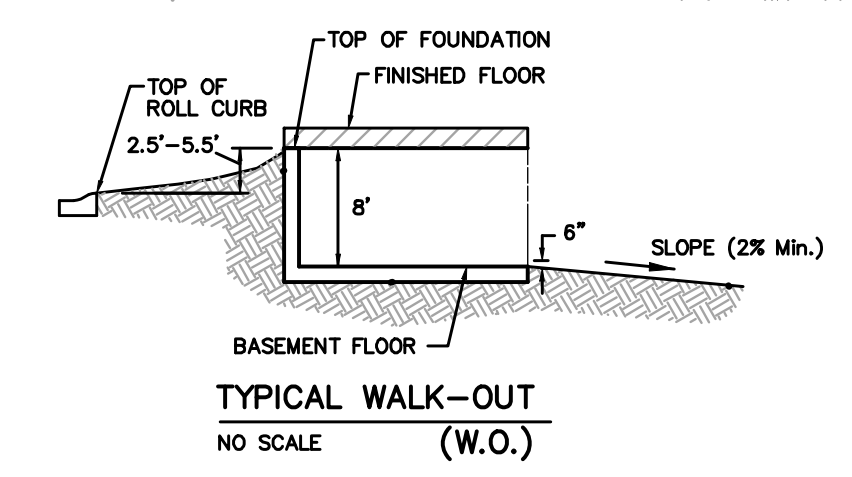
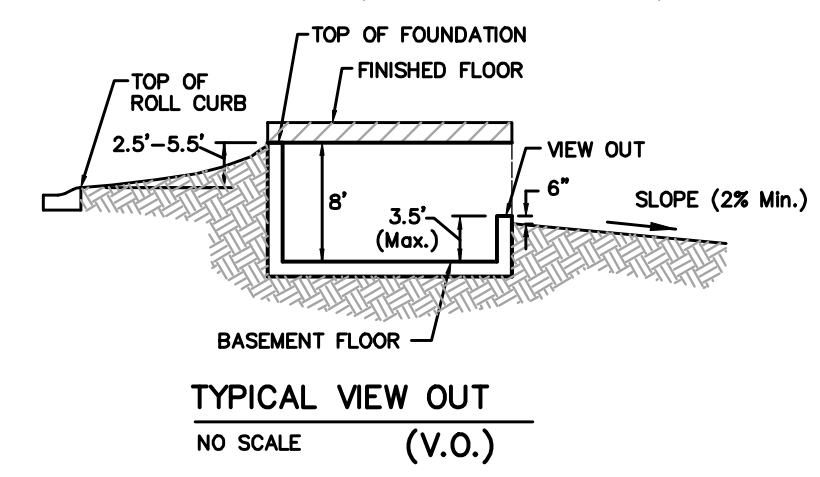
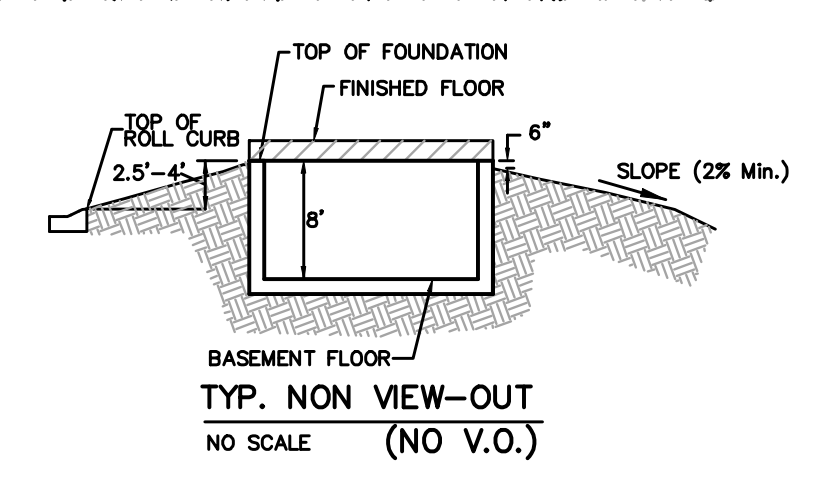

**Baughman** Turkey Creek 2nd Addition  
**Grading Plan**  
City of Wichita, Kansas

Baughman Company, P.A. 315 Ellis St. Wichita, KS 67211 P 316-262-7271 F 316-262-0149  
ENGINEERING | SURVEYING | PLANNING | LANDSCAPE ARCHITECTURE

PROJECT NUMBER	DESIGN	DRAWN
BLG/MWS	MWS	MWS
APPROVED	DATE	02/04
REVISIONS:	APRIL 22, 2004	MWS
June 3, 2005	Revised T.F. and V.O. grades	MWS
4/12/06	Revised T.F. and V.O. grades - Phase 1 only	MWS/JAK
	Revised T.F. and V.O. grades Phase 2	MWS/JAK
SCALE	NOTED	
SHEET		

**2 OF 3**

F:\Grading\Turkey Creek\grdcd.dwg