

# Four Corner Lot Grading

## THE LEGACY 3RD ADDITION

### Wichita, Sedgwick County, Kansas

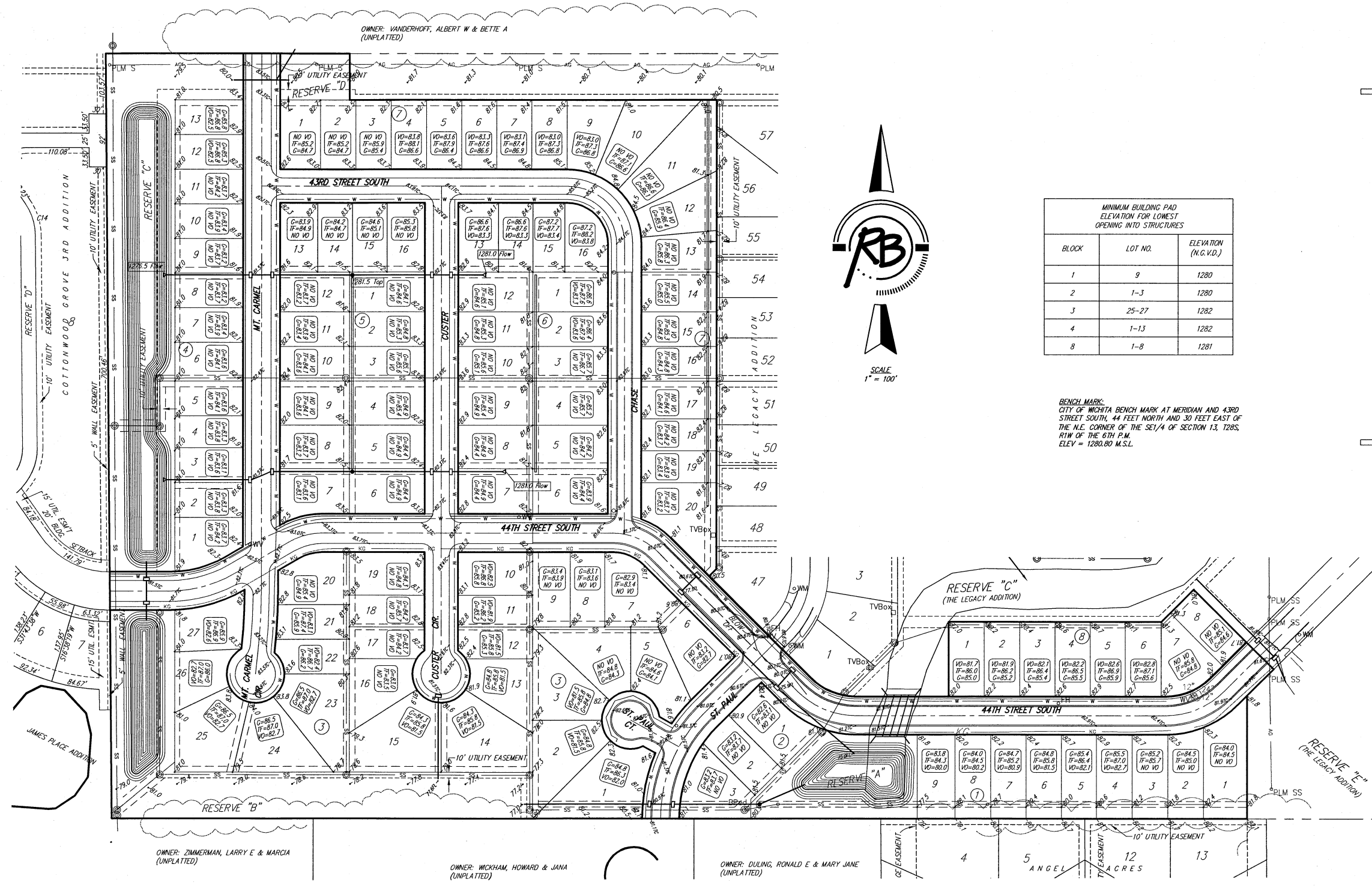

MINIMUM BUILDING PAD ELEVATION FOR LOWEST OPENING INTO STRUCTURES

BLOCK	LOT NO.	ELEVATION (M.C.V.D.)
1	9	1280
2	1-3	1280
3	25-27	1282
4	1-13	1282
8	1-8	1281

BENCH MARK:  
CITY OF WICHITA BENCH MARK AT MERIDIAN AND 43RD STREET SOUTH, 44 FEET NORTH AND 30 FEET EAST OF THE N.E. CORNER OF THE SE1/4 OF SECTION 13, T28S, R1W OF THE 6TH P.M.  
ELEV = 1280.80 M.S.L.

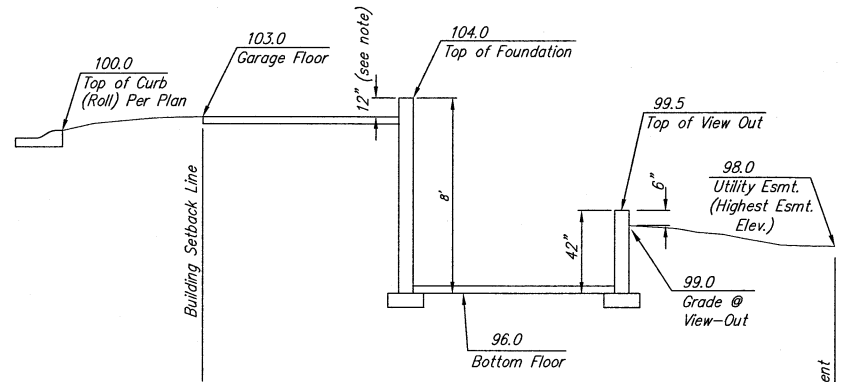

Section Through Typical View-Out Lot

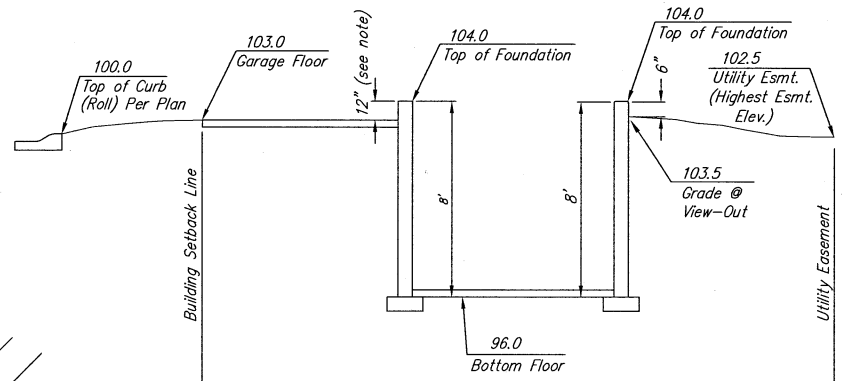

Section Through Typical Full Basement

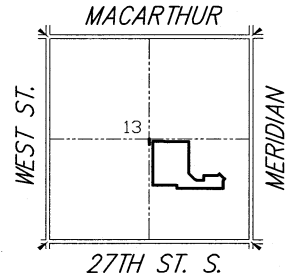
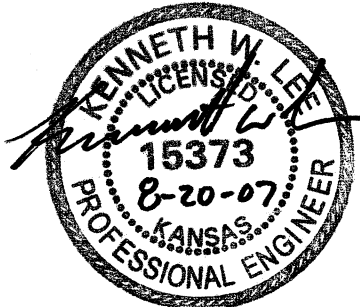

Ruggles & Bohm, P.A.  
Engineering, Surveying, Land Planning  
924 North Main (316) 264-8008  
Wichita, Kansas 67203 (316) 264-4621 fax  
www.rbkansas.com E-mail: info@rbkansas.com