

2. The pump housing can be filled with lubricant via the breather (A) on the cover. For this purpose remove the breather cap (B) and position a funnel (C) in the breather. Pour the lubricant into the pump housing through the funnel.
3. Keep on pouring until the lubricant level has risen above the low level line in the inspection window. Place back the breather cap.

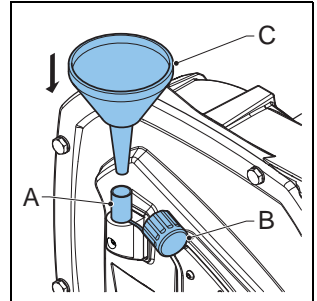

	For the required quantity of lubricant, refer to § 11.1.4.
--	--

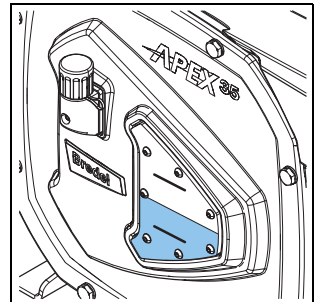

## 8.5 Replacing the pump hose

### 8.5.1 Removing the pump hose

1. Isolate the pump from the electrical supply.
2. Close any shut-off valves in the suction and discharge line to minimise product loss.
3. Place a tray (A) under the drain plug in the bottom of the pumphead. The tray must be large enough to contain the lubricant, possibly contaminated with process fluid, from the pumphead. Remove the drain plug (B). Catch the lubricant from the pump housing in the tray. Check that the breather mounted on the cover is not obscured. Place back the drain plug and tighten it.

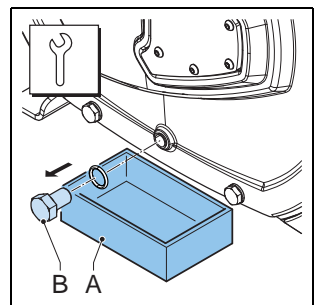

4. Disconnect the suction and discharge lines from the brackets.



**WARNING**

When disconnecting the suction and discharge lines, process fluid can escape. The pump hose may still contain process fluid, after the suction and discharge lines are disconnected.

5. Loosen the four bolts (A) of the bracket (B) and remove the bolts and the washers. The bracket will be pushed back slightly while removing the bolts.

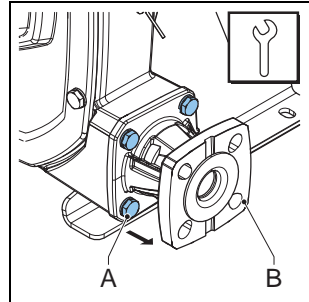

6. Pull the insert out of the hose. If necessary, insert the tip of a screwdriver behind the flange of the insert.

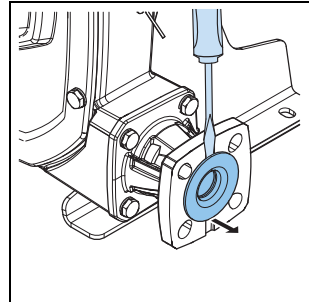

7. With the insert (B) removed, pull the bracket (A) off the hose. If the compression ring (C) stays on the hose, remove it from the hose. Do steps 5 to 7 for both the inlet and outlet ports.

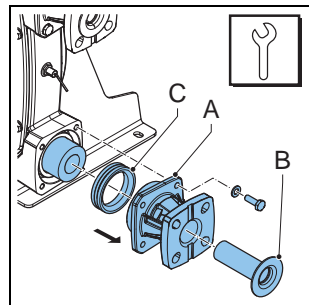

8. Switch on the electrical supply.

- Drive out the hose (A) from the pump housing by jogging the drive motor.

**WARNING**

During jogging the drive:

- Do not stand in front of the pump ports.
- Do not try to guide the hose by hand.

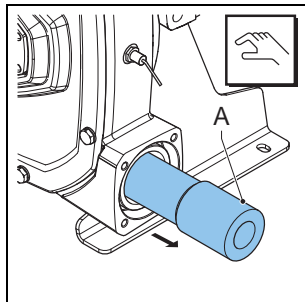
**8.5.2 Cleaning the pumphead**

- Isolate the pump from the electrical supply.
- Remove the cover (B) by loosening the bolts (A).
- Check the cover seal (C) and replace it if necessary.
- Rinse the pumphead with clean water and remove all residues. Clean the pockets in the pump housing. Make sure that no rinsing water remains in the pumphead.
- Check the rotor for wear or damage and replace the rotor if necessary. Also refer to the maintenance diagram in § 8.2.

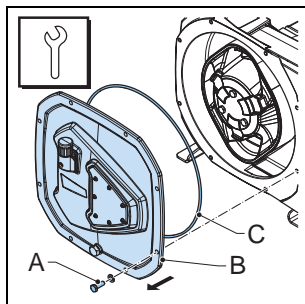
**CAUTION**

When the rotor is worn the compression force of the hose decreases. A compression force that is too low results in a loss of capacity due to the backflow of the process fluid. Backflow results in a reduction of the life of the pump hose.

6. Place back the cover and fasten the retaining bolts to the correct torque. Refer to § 11.1.6.
7. Switch on the electrical supply to the pump.

**8.5.3 Fitting the pump hose**

1. Clean the (new) pump hose on the outside and fully lubricate the outside with Bredel Genuine Hose Lubricant.
2. Fit the pump hose (A) via one of the ports.
3. Run the motor so that the rotor pulls the hose into the pump housing. Stop the motor when the hose sticks out equally from both sides of the pump housing.

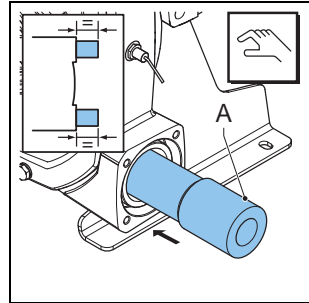

	<p><b>WARNING</b></p> <p>During jogging the drive:</p> <ul style="list-style-type: none"> <li>- Do not stand in front of the pump ports.</li> <li>- Do not try to guide the hose by hand.</li> </ul>
--	--

4. Check that the rubber compression rings (A) are not deformed or damaged and replace them if necessary.
5. First fit the inlet port.  
Fit the compression ring (A) in the bracket (B) and lubricate both the ring (as shown) and the hose end with Bredel Genuine Hose Lubricant. Using lubricant enables a smooth assembly.

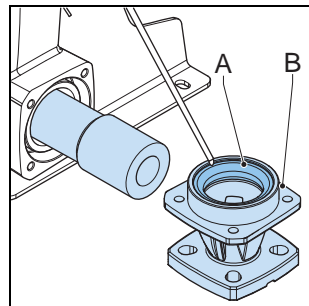

6. Slide the bracket (A) with the compression ring over the hose (B). Be aware that the bracket has an asymmetric shape and that the cam (C) must point to the back side of the pump.
7. Insert the four bolts (D) and tighten them only with hand force. Make sure that the compression ring is not already compressed.
8. If the hose is not yet at its end position, then turn the rotor in such a way that the hose (A) is pressed against its end position in the bracket (B).
9. Lubricate the insert (A) with Bredel Genuine Hose Lubricant. Manually spread the lubricant over the insert.
10. Push the insert (A) in the bracket (B) and the hose (C). Use hand force only. If the bolts (D) were tightened too much in step 7, loosen them a little to make the insertion easier.

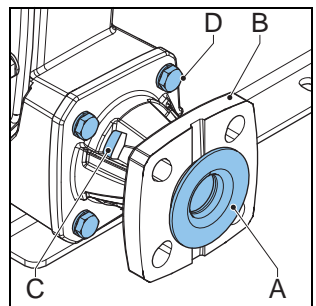
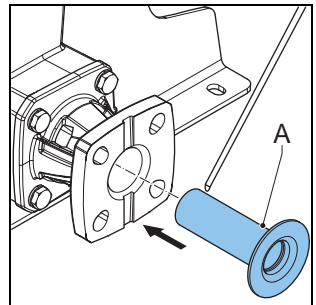
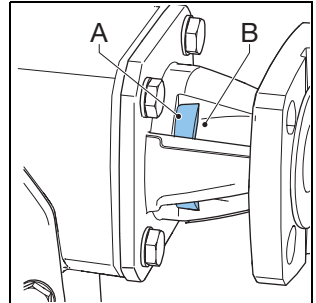
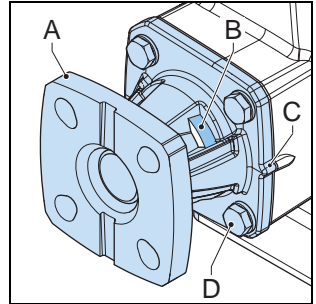

11. Tighten the bolts (A). Normally, it is sufficient to tighten two bolts that are diagonally opposite each other. The other two bolts can be tightened when the bracket is at its end position. Make sure the bolts are tightened to the correct torque. Refer to § 11.1.6.

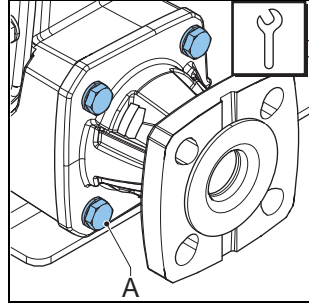

12. Although the insert (A) stays at its position when the bracket (B) is in the end position, the insert may be pushed out slightly while the bracket is pulled against the pump port (C). In that case, use a plastic hammer to gently drive in the insert to its end position while tightening the bolts (D).

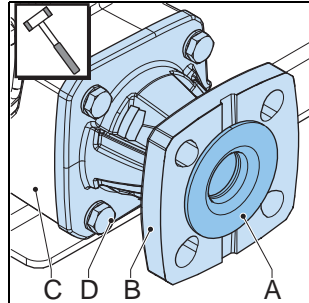

13. Now fit the other port in the same way.
14. Fill the pump housing with Bredel Genuine Hose Lubricant. Refer to § 8.4.
15. Connect the suction and discharge lines.
16. If applicable: before the pump is put into operation, open any shut-off valves in the suction and discharge lines.

## 8.6 Exchanging replacement parts

### 8.6.1 Replacing the rotor

1. Remove the pump hose. Refer to § 8.5.1.
2. Isolate the pump from the electrical supply.

3. Remove the cover (B) by loosening the retaining bolts (A).

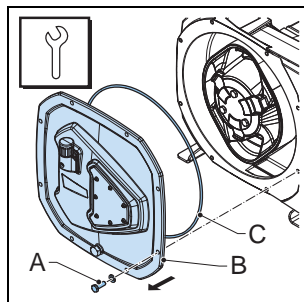

4. Check the cover seal (C) and replace it if necessary.

5. Remove the three retaining bolts and washers (A) and take the rotor (B) off the pump shaft (C).

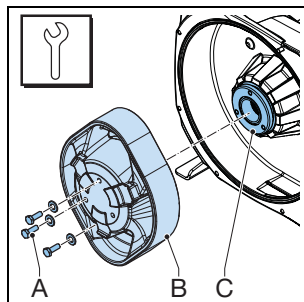

6. Check the outside of the dynamic seal (A) for deformation or damage as far as possible. The dynamic seal is partly covered by the pump shaft. Replace the dynamic seal if necessary. Refer to § 8.6.2.

Replace the O-ring (B), if necessary.

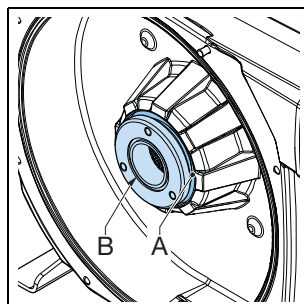

7. Fit the (new) rotor (B) on the pump shaft (C). Install the retaining bolts and washers (A) and tighten them to the correct torque. Refer to § 11.1.6.

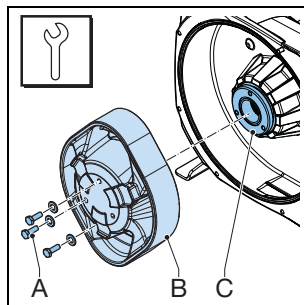

8. Refit the cover (B) and the seal (A) (if it was removed). Make sure that the eight bolts (C) are refitted and that they are tightened in the correct order, diagonally opposite each other. Refer to § 11.1.6.
9. Switch on the electrical supply to the pump.
10. Fit the (new) pump hose. Refer to § 8.5.3.

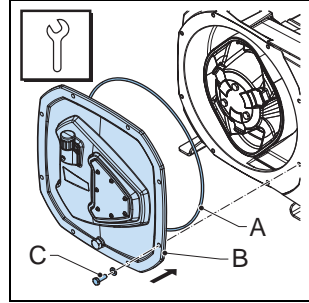

**8.6.2 Replacing the bearing, seal ring, shaft and coupling bush**

1. Remove the hose, the cover and the rotor. Refer to § 8.6.1, steps 1 to 5.
2. Remove the four bolts (A) and washers and remove the pump drive from the pump housing.
3. Check the teeth on the coupling bush (A) that is on the output shaft of the gearbox (B) for wear and damage. Replace the coupling bush if necessary.

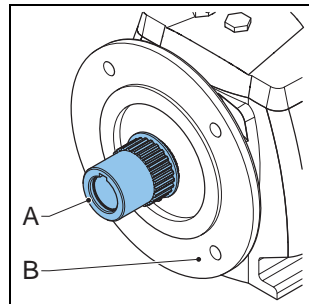
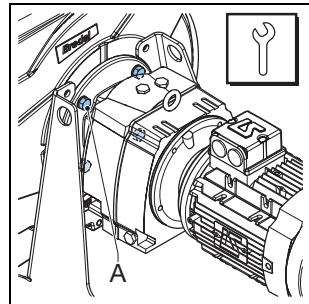

- Use circlip pliers to remove the circlip (A) from the pump shaft (B) and, if the bearing must be replaced, to remove the circlip (C) from the pump housing (D).



Circlip (A) locks the inner ring of the bearing.  
Circlip (C) locks the outer ring of the bearing.

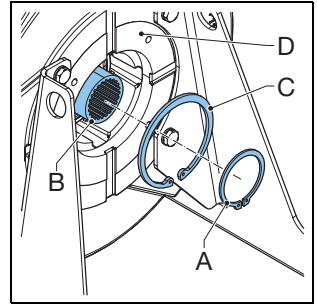

- At the back of the pump housing, gently drive out the pump shaft (A). Use a plastic hammer.
- Check the teeth (B) and the contact surface (C) for the dynamic seal for wear and damage. Replace the pump shaft if necessary.

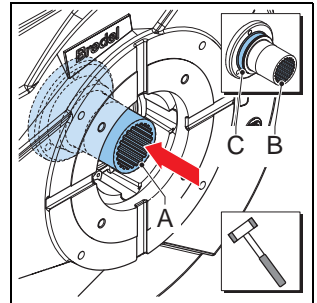

- At the back of the pump housing, drive out the dynamic seal (A) via the paths of the leakage zone (B). Use a driver and a plastic hammer.
- If it is not necessary to replace the bearing, go to step 13.

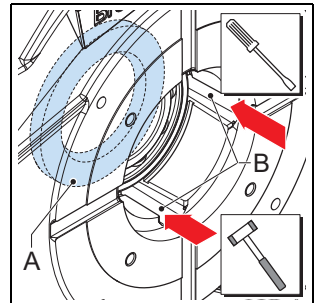

- At the front of the pump housing, place a suitable bush (A) against the outer ring (B) of the bearing. The outer diameter of the bush (A) must be  $103 \pm 1$  mm ( $4.06 \pm 0.04$  in). Use a plastic hammer to gently drive out the bearing.

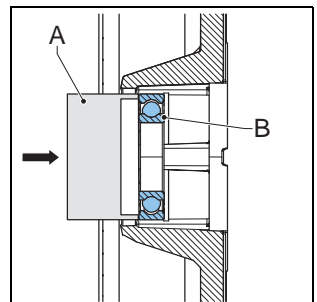

10. Make sure that all parts are clean before assembly.
11. At the back of the pump housing, position the (new) bearing in the bore. Place a suitable bush (A) against the outer ring (B) of the bearing. The outer diameter of the bush (A) must be  $109 \pm 1$  mm ( $4.29 \pm 0.04$  in). Use a plastic hammer to gently drive in the bearing, until it is in its end position against the edge in the pump housing.
12. From the back side of the pump housing, use circlip pliers to install the circlip (A) in the groove of the pump housing (B).

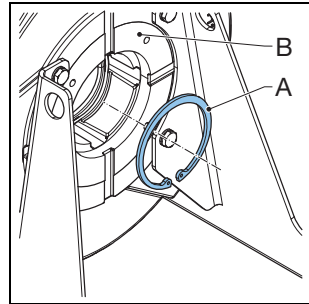
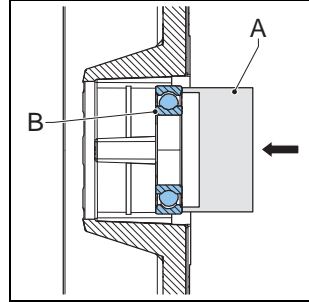

	<p>Circlip (A) locks the outer ring of the bearing.</p>
---	---

13. Slightly grease the sealing lip of the (new) dynamic seal (A). Do not grease the outside surface of the dynamic seal. Fit the dynamic seal from the front side in the pump housing, using good engineering practices. The seal ring must be fitted in the correct orientation. Make sure that the open side points towards the pump cover.
14. Slightly lubricate the contact surface of the inner ring of the bearing (A) and the pump shaft (B). Position the pump shaft in the bearing. Gently tap on the pump shaft until the collar touches the bearing. Use a plastic hammer.

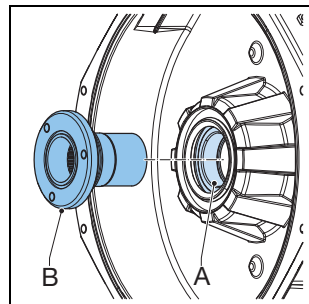
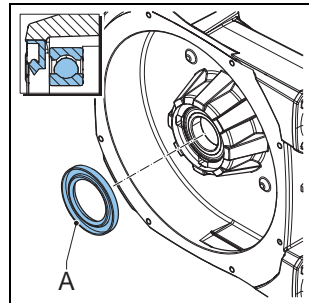

15. Install the (new) O-ring (A) in the pump shaft.

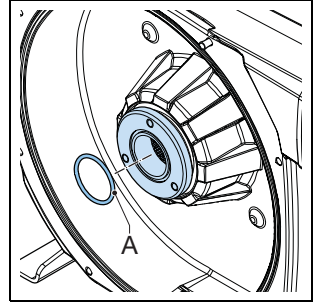

16. At the back of the pump housing, use circlip pliers to install the circlip (A) in the groove of the pump shaft (B).



Circlip (A) locks the inner ring of the bearing.

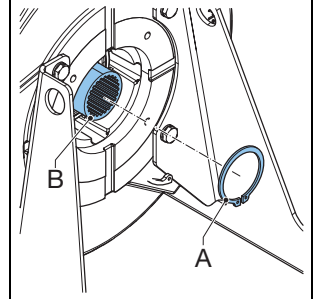

17. Make sure that the (new) coupling bush (A) has an inner circlip (C) at the front end and an outer circlip (A) at the back end.

18. If necessary, slightly grease the output shaft of the gearbox and position the (new) coupling bush on it. Use a plastic hammer to gently tap the coupling bush until the inner circlip touches the front end of the output shaft.

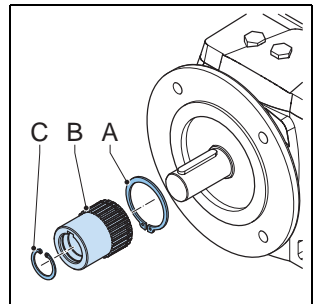

19. Grease the outer teeth (B) of the coupling bush with graphite grease.

20. Position the gearbox on the pumphead. Make sure that the spline coupling engages correctly. Position the four washers and bolts (A) and tighten the bolts to the correct torque. Refer to § 11.1.6.
21. Install the rotor, the cover and the hose. Refer to § 8.6.1, steps 6 to 10.

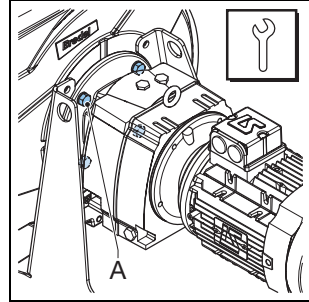

**8.7 Fitting options**

**8.7.1 Fitting a high-level float switch**

1. Dismount the standard breather (A) on the cover of the pumphead.
2. Mount the breather (A) with high-level float switch.

