

D-26 250 PSI

With Non-Slam



Combination Air Valve for Wastewater

Description

The D-26 Combination Air Valve combines an air & vacuum component and an air release component in a single body. The valve is specifically designed to operate with liquids carrying solid particles such as wastewater and effluents. The combination air valve discharges air (gas) during the filling or charging of the system, admits air into the system during drainage and at water column separation and releases accumulated air (gas) from the system while it is operating under pressure. The valve's unique design enables the separation of the liquid from the sealing mechanism and assures optimum working conditions.

Applications

- Wastewater and water treatment plants.
- Wastewater and effluent water transmission lines.

Operation

The air & vacuum component discharges air at high flow rates during the filling of the system and admits air into the system at high flow rates during its drainage and at water column separation.

At any time during system operation, should internal pressure of the system fall below atmospheric pressure, air will enter the system.

The smooth discharge of air reduces pressure surges and other destructive phenomena.

The intake of air in response to negative pressure protects the system from destructive vacuum conditions and prevents damage caused by water column separation. Air entry is essential to efficiently drain the system.

The air release component releases entrapped air in pressurized systems.

Without air valves, pockets of accumulated air may cause the following hydraulic disturbances:

- Restriction of effective flow due to a reduction of the flow area. In extreme cases this will cause complete flow stoppage.
- Obstruction of efficient hydraulic transmission due to air flow disturbances.
- Acceleration of cavitation damages.
- Increase in pressure transients and surges.
- Internal corrosion of pipes, fittings and accessories.
- Dangerous high-energy bursts of compressed air.
- Inaccuracies in flow metering.

As the system fills and is pressurized, the combination wastewater air valve functions in the following stages:

1. Air (gas) is discharged by the valve
2. When the liquid level reaches the valve's lower portion, the float is lifted, pushing the sealing mechanism to its sealing position.

3. The entrapped air is confined in a pocket between the liquid and the sealing mechanism. The air pressure is equal to the system pressure.

4. Increases in system pressure compress the trapped air in the upper section of the conical chamber. The conical shape assures the height of the air gap. This enables separation of the liquid from the sealing mechanism.

5. Entrapped air (gas), accumulating at peaks and along the system, rises to the top of the valve and displaces the liquid in the valve's body.

6. When the liquid level lowers to a point where the float is no longer buoyant, the float drops, unsealing the air release sealing assembly. The air release orifice opens and allows part of the air that accumulated in the upper portion of the valve to be released to the atmosphere.

7. Liquid enters the valve. The float rises, pushing the air release sealing assembly to its sealing position. The remaining air gap prevents the wastewater from fouling the mechanism.

When internal pressure falls below atmospheric pressure (negative pressure):

1. The float will drop down, immediately opening the air & vacuum and air release orifices.
2. Air will enter into the system.

Main Features

Working pressure range: 1.5 – 250

- Testing pressure: 1.5 times the max. working pressure.
- Maximum working temperature: 140° F.
- Maximum intermittent temperature: 194° F.
- The unique design of the valve prevents contact between the wastewater and the sealing mechanism by creating an air gap at the top of the valve. These features are achieved by:
 - **The conical body shape and the external guide rod/disc arm:** designed to maintain the maximum distance between the liquid and the sealing mechanism and still obtain minimum body length.
 - **Spring-guided linkage between the float/rod assembly and the sealing mechanism:** allows free movement of the float and rod. Vibrations and movement of the float due to turbulence will not unseat the sealing mechanism.
 - **Funnel-shaped lower body:** designed to ensure that residue wastewater matter will fall back into the system and be carried away by the main pipe.
- All inner metal parts made of stainless steel.
- Discharge outlet enables connection of a vent pipe.
- The ball valve can be opened to release trapped pressure and drain the valve body prior to maintenance and for back-flushing during maintenance.

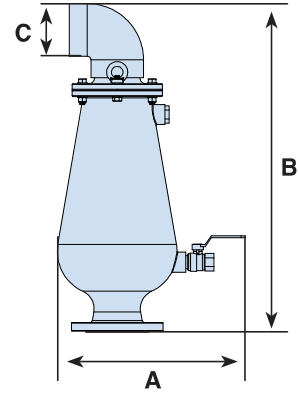

DIMENSIONS AND WEIGHTS

Model	Dimensions Inch		Connection	Weight Lbs.		Orifice Area Sq.In.	
	A	B		ST	ST	A / V	Auto.
D-26 NS 2" Threaded	13.0	21.8	2" NPSM Male	30.0		3.04	0.0133

NS Non-Slam Add-on Component Data Table for Variable Orifices

Nominal Size	Holes number	Discharge Orifice Inch	Total NS area Sq.In.	NS orifice Inch	Switching point	Flow at 5.8 psi
2"	1 orifice	2	0.024	0.177	Spring loaded normally closed	14.1 CFM
	2 orifice	2	0.047	0.244		18.6 CFM
	3 orifice	2	0.074	0.307		23.5 CFM

D-26 NS 2"

AIR & VACUUM FLOWRATE

2" WITH ADJUSTABLE NS CHECK VALVE

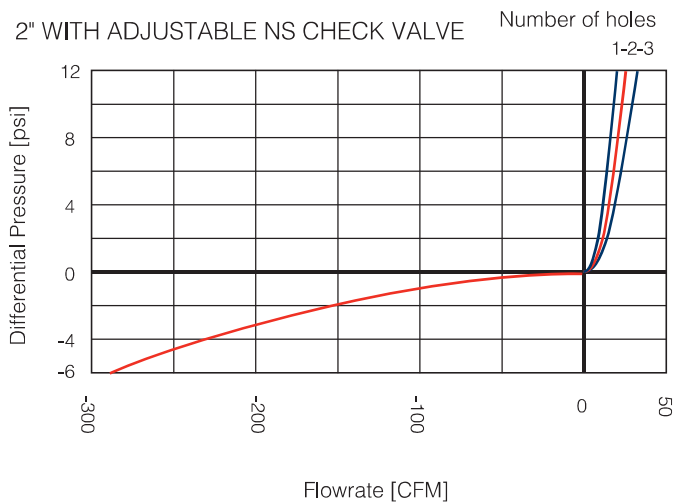

AIR RELEASE FLOWRATE

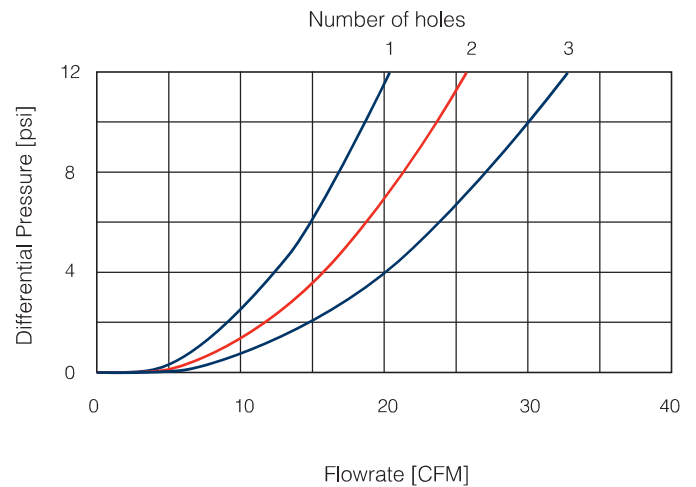

D-26 2" PARTS LIST AND SPECIFICATION

No.	Part	Material
1.	Threaded Plug	Polypropylene
2.	Cover	Stainless Steel SAE 316
3.	Disk Arm Assy.	Stainless Steel SAE 316
4.	O-ring	BUNA-N
5.	Air & Vacuum Seal	EPDM
6.	Air Release Seal	EPDM
7.	Spring	Stainless Steel SAE 316
8.	Spray Guard [®]	Polypropylene
9.	Body	Stainless Steel SAE 316
10.	Float	Polypropylene
11.	Clamp	Cast Stainless Steel
12.	O-ring	BUNA-N
13.	Tap	Stainless Steel
14.	Base	Stainless Steel SAE 316

15. NS Component



D-26 NS 2"

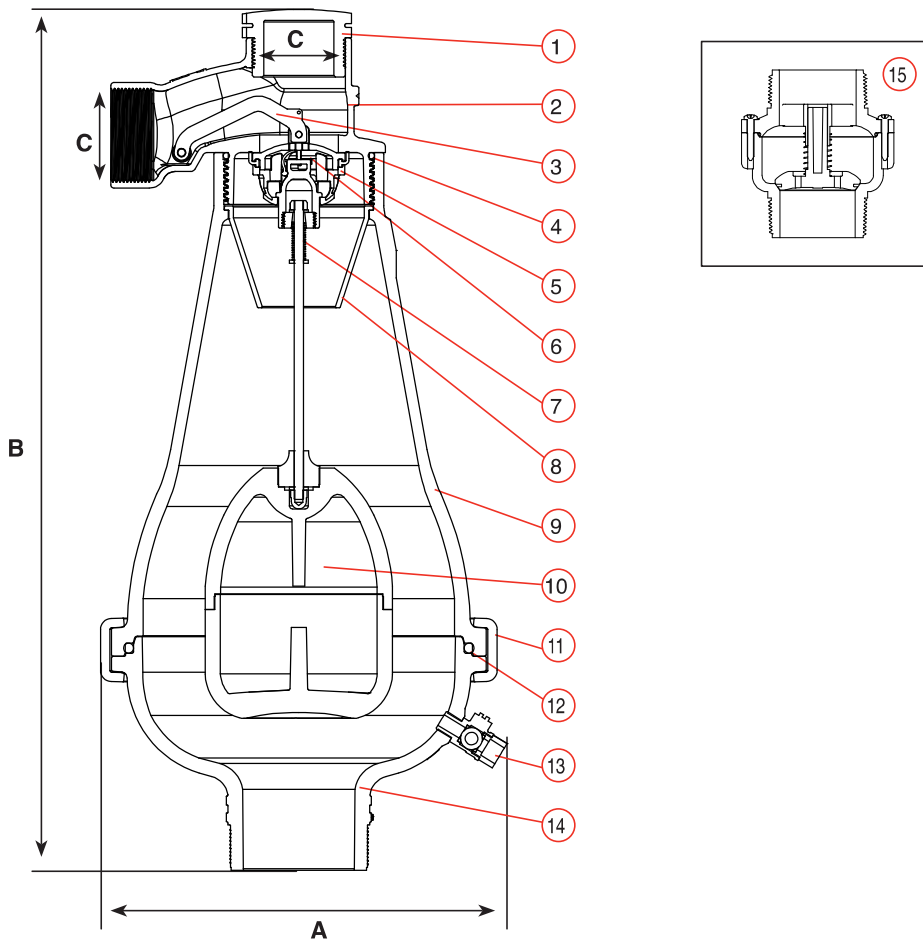

3" / D-26 250 PSI

With Non-Slam



Combination Air Valve for Wastewater

Description

The D-26 Combination Air Valve combines an air & vacuum component and an air release component in a single body. The valve is specifically designed to operate with liquids carrying solid particles such as wastewater and effluents. The combination air valve discharges air (gas) during the filling or charging of the system, admits air into the system during drainage and at water column separation and releases accumulated air (gas) from the system while it is operating under pressure. The valve's unique design enables the separation of the liquid from the sealing mechanism and assures optimum working conditions.

Applications

- Wastewater and water treatment plants.
- Wastewater and effluent water transmission lines.

Operation

The air & vacuum component discharges air at high flow rates during the filling of the system and admits air into the system at high flow rates during its drainage and at water column separation.

At any time during system operation, should internal pressure of the system fall below atmospheric pressure, air will enter the system.

The smooth discharge of air reduces pressure surges and other destructive phenomena.

The intake of air in response to negative pressure protects the system from destructive vacuum conditions and prevents damage caused by water column separation. Air entry is essential to efficiently drain the system.

The air release component releases entrapped air in pressurized systems.

Without air valves, pockets of accumulated air may cause the following hydraulic disturbances:

- Restriction of effective flow due to a reduction of the flow area. In extreme cases this will cause complete flow stoppage.
- Obstruction of efficient hydraulic transmission due to air flow disturbances.
- Acceleration of cavitation damages.
- Increase in pressure transients and surges.
- Internal corrosion of pipes, fittings and accessories.
- Dangerous high-energy bursts of compressed air.
- Inaccuracies in flow metering.

As the system fills and is pressurized, the combination wastewater air valve functions in the following stages:

1. Air (gas) is discharged by the valve
2. When the liquid level reaches the valve's lower portion, the float is lifted, pushing the sealing mechanism to its sealing position.

3. The entrapped air is confined in a pocket between the liquid and the sealing mechanism. The air pressure is equal to the system pressure.
4. Increases in system pressure compress the trapped air in the upper section of the conical chamber. The conical shape assures the height of the air gap. This enables separation of the liquid from the sealing mechanism.
5. Entrapped air (gas), accumulating at peaks and along the system, rises to the top of the valve and displaces the liquid in the valve's body.
6. When the liquid level lowers to a point where the float is no longer buoyant, the float drops, unsealing the air release sealing assembly. The air release orifice opens and allows part of the air that accumulated in the upper portion of the valve to be released to the atmosphere.
7. Liquid enters the valve. The float rises, pushing the air release sealing assembly to its sealing position. The remaining air gap prevents the wastewater from fouling the mechanism.

When internal pressure falls below atmospheric pressure (negative pressure):

1. The float will drop down, immediately opening the air & vacuum and air release orifices.
2. Air will enter into the system.

Main Features

Working pressure range: 3 - 250 psi

- Testing pressure: 1.5 times the max. working pressure.
- Maximum working temperature: 140° F.
- Maximum intermittent temperature: 194° F.
- The unique design of the valve prevents contact between the wastewater and the sealing mechanism by creating an air gap at the top of the valve. These features are achieved by:
 - **The conical body shape and the external guide rod/disc arm:** designed to maintain the maximum distance between the liquid and the sealing mechanism and still obtain minimum body length.
 - **Spring-guided linkage between the float/rod assembly and the sealing mechanism:** allows free movement of the float and rod. Vibrations and movement of the float due to turbulence will not unseat the sealing mechanism.
 - **Funnel-shaped lower body:** designed to ensure that residue wastewater matter will fall back into the system and be carried away by the main pipe.
- All inner metal parts made of stainless steel.
- Discharge outlet enables connection of a vent pipe.
- The ball valve can be opened to release trapped pressure and drain the valve body prior to maintenance and for back-flushing during maintenance.

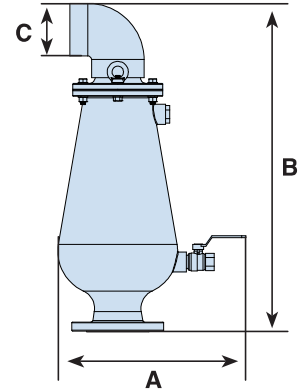

DIMENSIONS AND WEIGHTS

Model	Dimensions Inch		Connection	Weight Lbs.		Orifice Area Sq.In.	
	A	B		RN	ST ST	A / V	Auto.
D-26 NS 3" Threaded	16.2	24.4	3" NPSM Male		51.8	7.787	0.024

D-26 NS 3" (D-023)

3" WITH ADJUSTABLE NS CHECK VALVE

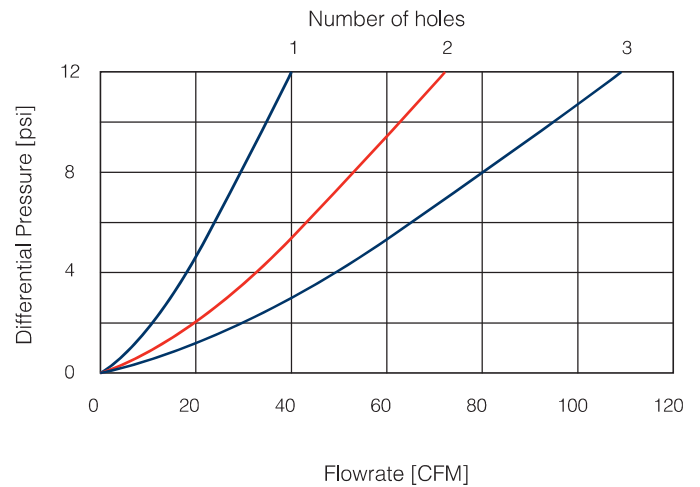
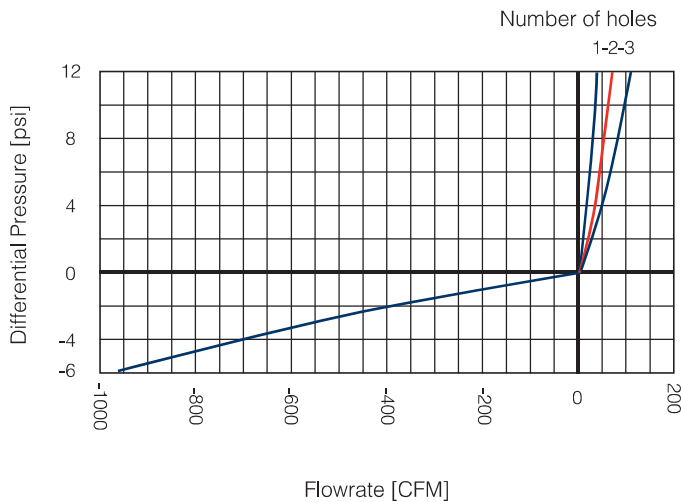

NS Non-Slam Add-on Component Data Table for Variable Orifices

Nominal Size	Holes number	Discharge Orifice Inch	Total NS area Sq.In.	NS orifice Inch	Switching point	Flow at 5.8 psi
2"	1 orifice	2	0.024	0.177	Spring loaded normally closed	14.1 CFM
	2 orifice	2	0.047	0.244		18.6 CFM
	3 orifice	2	0.074	0.307		23.5 CFM
3"	1 orifice	3	0.078	0.314	Spring loaded Normally closed	22.64 CFM
	2 orifice	3	0.15	0.445		42.67 CFM
	3 orifice	3	0.23	0.547		65.54 CFM
4"	1 orifice	4	0.125	0.4	Spring loaded normally closed	88.29 CFM
	2 orifice	4	0.244	0.555		108.9 CFM
	3 orifice	4	0.365	0.681		135.4 CFM
6"	1 orifice with graduated closure	6	1.095	1.181	0.36 psi	930 CFM
8"		8	2.544	1.8	0.036 psi	1112.4 CFM

D-26 3" (D-023)
PARTS LIST AND SPECIFICATION - STAINLESS BODY

No.	Parts	Material
1.	Disk Arm Assembly	Stainless Steel SAE 316 + EPDM
2.	Cover	Stainless Steel SAE 316
3.	Plug	Polypropylene
4.	Air & Vacuum Disc	Reinforced Nylon / Cast ST ST
5.	Air Release Seal	EPDM
6.	Bolt, Nut & Washer	Stainless Steel SAE 316
7.	O-ring	BUNA-N
8.	Air & Vacuum Seal	EPDM
9.	Spray Guard®	Polypropylene
10.	Spring	Stainless Steel SAE 316
11.	Body	Stainless Steel SAE 316
12.	Float Assy.	Stainless Steel SAE 316 + Polypropylene
13.	Ball Valve	Stainless Steel SAE 316
14.	NS Component	Reinforced Nylon

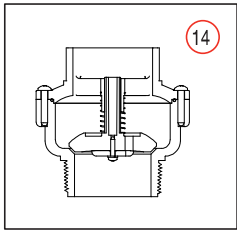
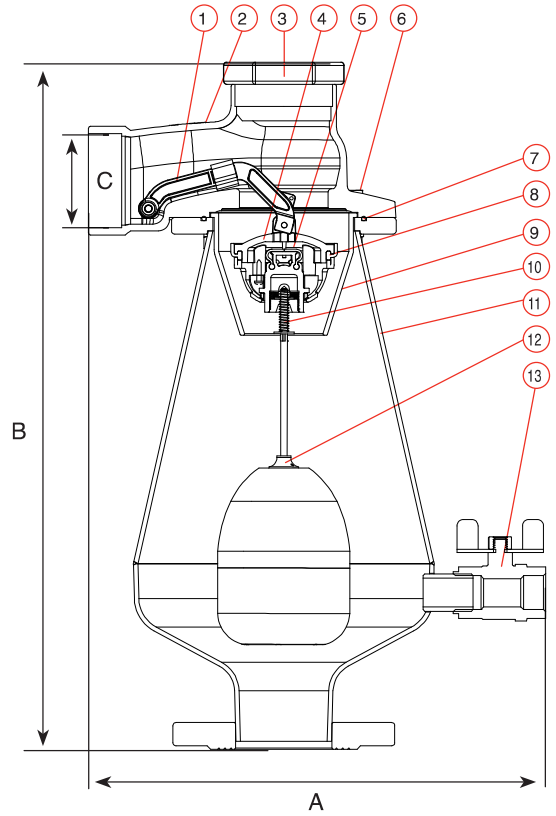



Female NPT Thread, 1/4"-3" 1000 CWP (psig), Cold Non-Shock. (See referenced P/T chart)
 150 psig Saturated Steam.
 Vacuum Service to 29 inches Hg.
 MSS SP-110 Compliant.
 Designed, cast, machined, assembled, and 100% factory tested in USA.

FEATURES

- Investment cast components
- Reinforced seats
- Blowout-proof stem design
- Adjustable packing gland
- Stainless steel lever and nut

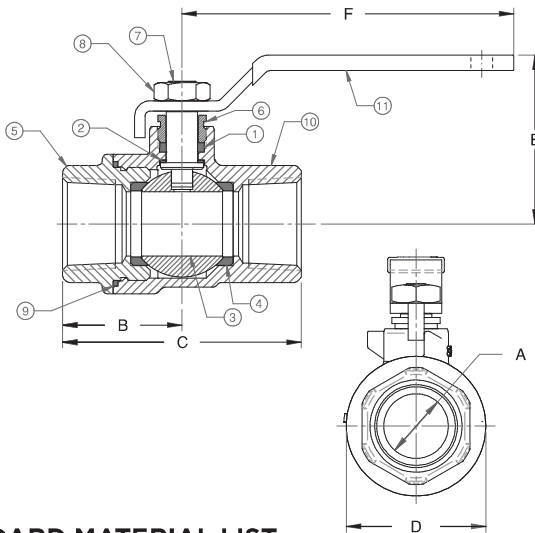

STANDARD MATERIAL LIST

PART	MATERIAL
1	Stem packing MPTFE
2	Stem bearing RPTFE
3	Ball A276-316SS (1/4" to 2", except 1.25") A276-316SS or A351-CF8M stainless (1.25") A351-CF8M stainless (3")
4	Seat (2) RPTFE (2" & smaller); RTFM (3")
5	Retainer ASTM A276-316SS (1/4" & 3/8") ASTM A351-CF8M stainless (1/2" to 3")
6	Gland A276-316 Stainless Steel
7	Stem A276-316 Stainless Steel
8	Lever nut 304 Stainless Steel
9	Body Seal RPTFE (1/2" to 3")
10	Body A351-CF8M
11	Lever and grip SS w/vinyl

DIMENSIONS

PRODUCT NO.	SIZE	A	B	C	D	E	F	WT.
76F-101-01	1/4"	0.37	0.95	1.91	1.12	1.60	3.85	0.47
76F-102-01	3/8"	0.37	0.95	1.91	1.12	1.60	3.85	0.44
76F-103-01A	1/2"	0.50	1.21	2.35	1.27	1.73	3.85	0.57
76F-104-01A	3/4"	0.81	1.39	2.77	1.62	1.96	3.85	0.91
76F-105-01A	1"	1.00	1.67	3.34	2.00	2.27	4.75	1.38
76F-106-01A	1.25"	1.25	1.96	3.92	2.73	3.21	7.77	4.17
76F-107-01A	1.5"	1.50	2.05	4.10	2.92	3.31	7.77	4.69
76F-108-01A	2"	2.00	2.37	4.74	3.75	3.69	7.77	6.90
76F-100-01A	3"	3.00	3.70	7.40	5.68	5.23	10.00	22.40

*LEAD FREE: The wetted surfaces of this product shall contain no more than 0.25% lead by weighted average. Complies with Federal Public Law 111-380. ANSI 3rd party approved and listed.
 REV. 14FEB18

- Fire safe to API 607 (requires -24 suffix)
- Meets NACE MR0175 (2000) & MR0103 (2012)
- CSA CGA 3.16-M88 (Requires "GS" suffix)
- NSF/ANSI 61 Section 8, Annex G (1/4" to 2")
- NSF/ANSI 372 - Drinking Water System Components - Lead Content

OPTIONS AVAILABLE

(MORE INFORMATION IN SECTION J)

- Minimum quantities apply
- To specify an option, replace the "01" standard suffix with the suffix of the option.
- To specify multiple options, replace the "01" suffix with the desired suffixes in the numerical order shown below. NOTE: Not all suffixes can be combined together.

(SUFFIX)	OPTION	SIZES
-01	Standard Configuration	All
-P -01-	BSPP (Parallel) Thread Connection	1/2" to 2"
-T -01-	BSPT (Tapered) Thread Connection	1/2" to 3"
-02-	Stem Grounded	1/2" to 3"
-04-	2.25" Stem Extension (Carbon Steel, Zinc Plated)	1/2" to 2"
-08-	90° Reversed Stem	1/2" to 2"
-11-	Therma-Seal™ Insulating Tee Handle	1/4" to 2"
-14-	Side Vented Ball (Uni-Directional)	3/8" to 3"
-24-	Graphite packing, PTFE body seal, RPTFE bearing (Fire Safe API 607, 6th edition, ISO 10497:2010)	1/2" to 3"
-27-	SS Latch-Lock Lever & Nut	3/8" to 3"
-30-	Cam-Lock and Grounded	1/2" to 2"
-32-	SS Tee Handle & Nut	1/2" to 2"
-35-	PTFE Trim	3"
-39-	SS Hi-Rise Locking Wheel Handle, SS Nut	1/2" to 2"
-40-	Cyl-Loc and Grounded	1/2" to 2"
-44-	Seal Welded	1/4" to 3"
-45-	Less Lever & Nut	1/2" to 3"
-46-	Latch Lock Lever - Lock in Closed Position Only	1/2" to 2"
-47-	SS Latch Lock Oval Handle	1/2" to 2"
-48-	SS Oval Handle (No Latch) & Nut	1/4" to 2"
-49-	No Lubrication, Assembled Dry.	1/2" to 3"
-50-	2.25" CS Locking Stem Extension	1/2" to 2"
-56-	Multifill Seats & Packing	1/2" to 3"
-57-	Oxygen Cleaned	1/4" to 3"
-60-	Static Grounded Ball & Stem	1/2" to 3"
-GS	CSA CGA 3.16 (RTFE Seat - All sizes)	All

Pressure/Temperature Ratings - Page M-12, Graph No. 8

The listed C_v "factors" are derived from actual flow testing, at Apollo's Pageland, South Carolina factory. These tests were completed using standard "off the shelf" valves with no special preparation and utilizing standard schedule 40 pipe. It should be understood that these factors are for the valve only and also include the connection configuration. The flow testing is done utilizing water as a fluid media and is a direct statement of the gallons of water flowed per minute with a 1 psig pressure differential across the valve/connection unit. Line pressure is not a factor. Because the C_v is a factor, the formula can be used to estimate flow of most media for valve sizing.

FLOW OF LIQUID

$$Q = C_v \sqrt{\frac{\Delta P}{SpGr}}$$

$$\text{or } \Delta P = \frac{(Q)^2 (SpGr)}{(C_v)^2}$$

WHERE:

- Q = Flow in US gpm
- ΔP = Pressure drop (psig)
- SpGr = Specific gravity at flowing temperature
- C_v = Valve constant

FLOW OF GAS

$$Q = 1360 C_v \sqrt{\frac{(\Delta P) (P_2)}{(SpGr) (T)}}$$

$$\text{or } \Delta P = \frac{5.4 \times 10^{-7} (SpGr) (T) (Q)^2}{(C_v)^2 (P_2)}$$

WHERE:

- Q = Flow in SCFH
- ΔP = Pressure drop (psig)
- SpGr = Specific gravity (based on air = 1.0)
- P2 = Outlet pressure-psia (psig + 14.7)
- T = (temp. °F + 460)
- C_v = Valve constant

CAUTION: The gas equation shown, is valid at very low pressure drop ratios. The gas equation is NOT valid when the ratio of pressure drop (ΔP) to inlet pressure (P1) exceeds 0.02.

NOTE: Only use the gas equation shown if (P1-P2)/P1 is less than 0.02.

CV FACTORS FOR APOLLO® VALVES (CONTINUED ON M-4)

VALVE	SIZE (IN.)														
	1/4	3/8	1/2	3/4	1	1.25	1.5	2	2.5	3	4	6	8	10	12
70B-140 Series	8.4	7.2	15	30	43	48	84	108	190	370	670	--	--	--	--
70-100/200 Series	8.4	7.2	15	30	43	48	84	108	190	370	670	--	--	--	--
70-300/400 Series	--	--	15	30	43	48	84	108	--	--	--	--	--	--	--
70-600 Series	2.3	4.5	5.4	12	14	21	34	47	--	--	--	--	--	--	--
70-800 Series	8.4	7.2	15	30	43	48	84	--	--	--	--	--	--	--	--
71-AR Series	--	--	--	30	43	48	84	108	190	370	--	--	--	--	--
71-100/200 Series	--	--	--	30	43	48	84	108	190	370	--	--	--	--	--
72-100/900 Series	--	--	26	48	65	125	170	216	--	--	--	--	--	--	--
72-1xx-A/72-9xx-A Series	--	--	26	48	65	125	170	245	--	--	--	--	--	--	--
73A-100 Series	8.4	7.2	15	30	43	48	84	108	--	--	--	--	--	--	--
73-300/400 Series	--	--	26	48	65	125	170	216	--	--	--	--	--	--	--
74-100 Series	8.4	7.2	15	30	43	48	84	108	190	370	670	--	--	--	--
75-100 Series	8.4	7.2	15	30	43	48	84	108	190	370	670	--	--	--	--
76-AR Series	8.4	7.2	15	30	43	48	84	108	190	370	670	--	--	--	--
76F-100 Series	8.1	15	15	51	68	125	177	389	--	--	--	--	--	--	--
76FJ-100 Series	8.1	15	15	51	68	125	177	389	--	--	--	--	--	--	--
76FK-100 Series	8.1	15	15	51	68	125	177	389	--	--	--	--	--	--	--
76-100 Series	8.4	7.2	15	30	43	48	84	108	190	370	--	--	--	--	--
76-300/400 Series	--	--	26	48	65	125	170	216	--	--	--	--	--	--	--
76-600 Series	2.3	4.5	5.4	12	14	21	34	47	--	--	--	--	--	--	--
76J-100 Series	8.4	7.2	15	30	43	48	84	108	190	370	--	--	--	--	--
76J-AR Series	8.4	7.2	15	30	43	48	84	108	190	370	670	--	--	--	--
76K-100 Series	8.4	7.2	15	30	43	48	84	108	190	370	--	--	--	--	--
76K-AR Series	8.4	7.2	15	30	43	48	84	108	190	370	670	--	--	--	--
7K-100 Series	--	--	15	51	68	125	177	389	503	--	--	--	--	--	--
77-AR Series	8.1	15	15	51	68	--	177	389	--	--	--	--	--	--	--

REV. 21APR17

1000 CWP

(CS) ASTM A216-WCB

GRAPH 7

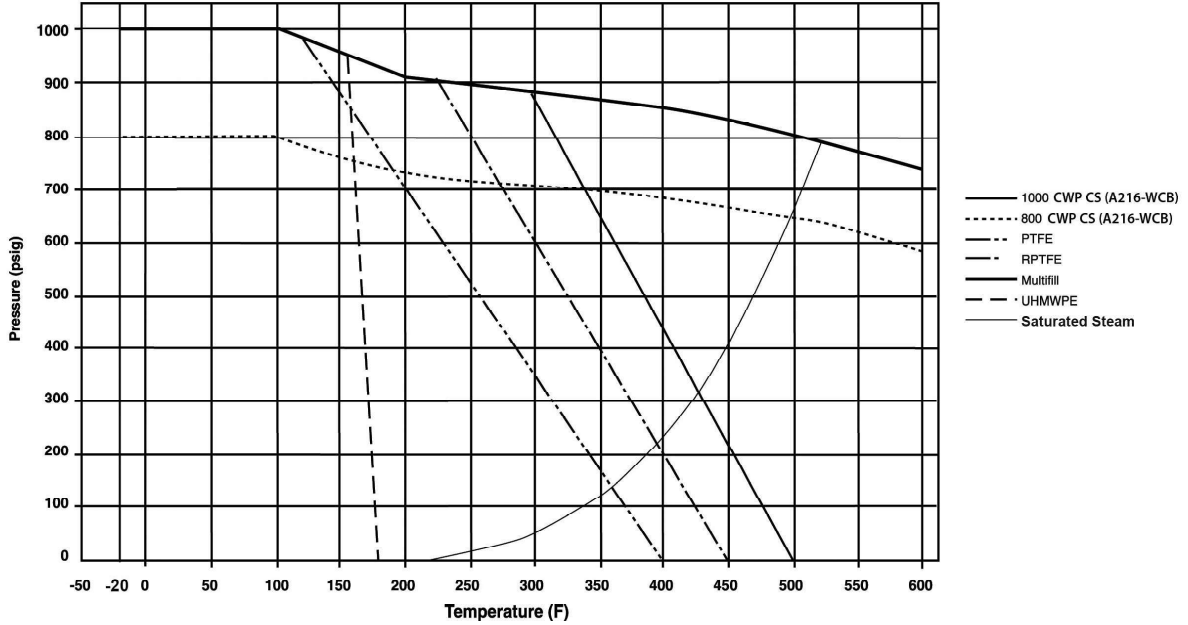

1000 CWP

(SS) ASTM A351-CF8M

GRAPH 8

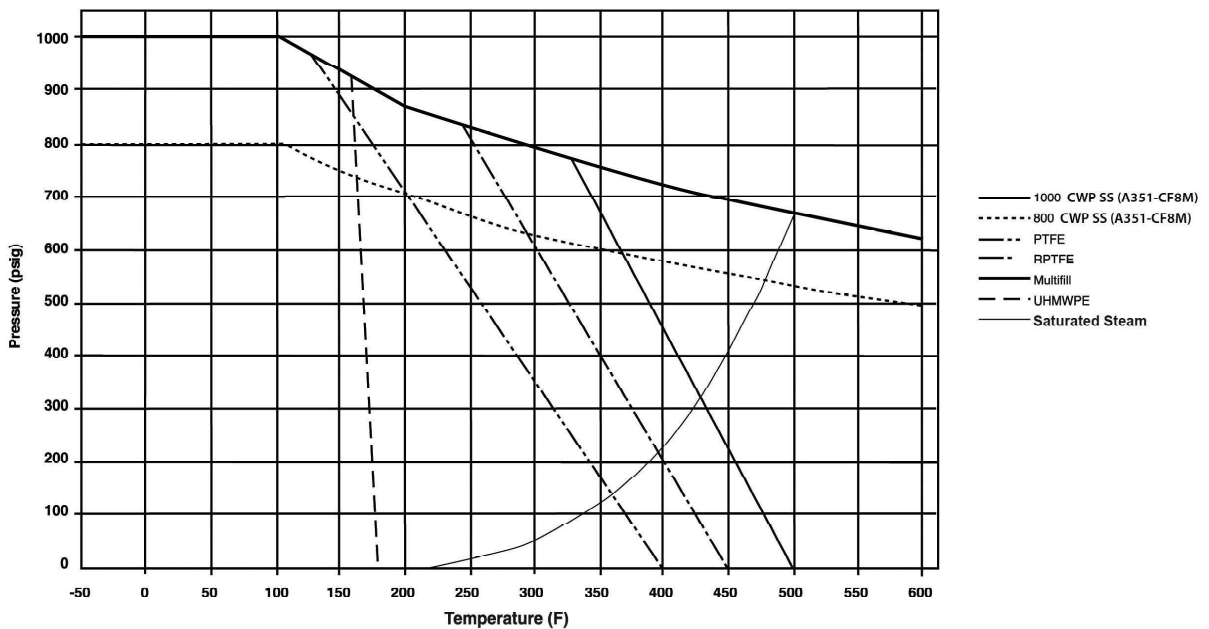

76F-100-A SERIES

STAINLESS STEEL FULL PORT BALL VALVE



Female NPT Thread, 1/4"-3" 1000 CWP (psig), Cold Non-Shock. (See referenced P/T chart)
 150 psig Saturated Steam.
 Vacuum Service to 29 inches Hg.
 MSS SP-110 Compliant.
 Designed, cast, machined, assembled, and 100% factory tested in USA.

FEATURES

- Investment cast components
- Reinforced seats
- Blowout-proof stem design
- Adjustable packing gland
- Stainless steel lever and nut

- Fire safe to API 607 (requires -24 suffix)
- Meets NACE MR0175 (2000) & MR0103 (2012)
- CSA CGA 3.16-M88 (Requires "GS" suffix)
- NSF/ANSI/CAN 61 Section 8, Annex G (1/4" to 3")
- NSF/ANSI 372 - Drinking Water System Components - Lead Content

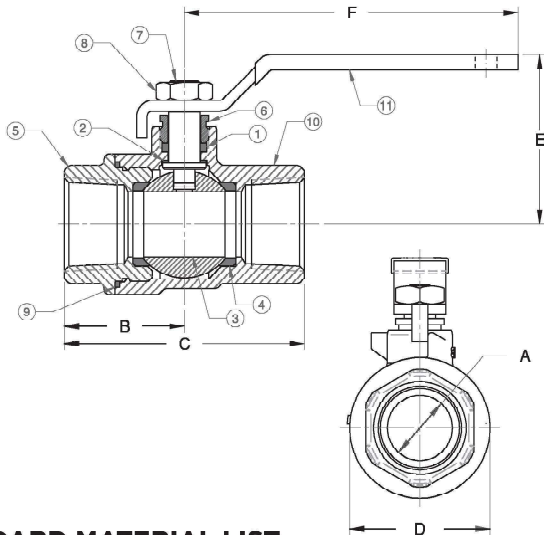

OPTIONS AVAILABLE

(MORE INFORMATION IN SECTION J)

- Minimum quantities apply
- To specify an option, replace the "01" standard suffix with the suffix of the option.
- To specify multiple options, replace the "01" suffix with the desired suffixes in the numerical order shown below. NOTE: Not all suffixes can be combined together.

(SUFFIX)	OPTION	SIZES
-01	Standard Configuration	All
-P -01-	BSPP (Parallel) Thread Connection	1/2" to 2"
-T -01-	BSPT (Tapered) Thread Connection	1/2" to 3"
-02-	Stem Grounded	1/2" to 3"
-04-	2-1/4" Stem Extension (Carbon Steel, Zinc Plated)	1/2" to 2"
08	90° Reversed Stem	1/2" to 2"
-11-	Therma-Seal™ Insulating Tee Handle	1/4" to 2"
-14-	Side Vented Ball (Uni-Directional)	3/8" to 3"
-24-	Graphite Packing, PTFE Body Seal, RPTFE Bearing (API 607, 6th Edition, ISO 10497:2010)	1/2" to 3"
-27-	SS Latch-Lock Lever & Nut	3/8" to 3"
-30-	Cam-Lock and Grounded	1/2" to 2"
-32-	SS Tee Handle & Nut	1/2" to 2"
-35-	PTFE Trim	3"
-39-	SS Hi-Rise Locking Wheel Handle, SS Nut	1/2" to 2"
-40-	Cyl-Loc and Grounded	1/2" to 2"
-44-	Seal Welded	All
-45-	Less Lever & Nut	1/2" to 3"
-46-	Latch Lock Lever - Lock in Closed Position Only	1/2" to 2"
-47-	SS Latch Lock Oval Handle	1/2" to 2"
-48-	SS Oval Handle (No Latch) & Nut	1/4" to 2"
-49-	No Lubrication. Assembled Dry.	1/2" to 3"
-50-	2-1/4" CS Locking Stem Extension	1/2" to 2"
-56-	Multifill Seats & Packing	1/2" to 3"
-57-	Oxygen Cleaned	All
60	Static Grounded Ball & Stem	1/2" to 3"
-GS-	CSA CGA 3.16 (RTFE Seat - All sizes)	All
-UA-	AIS (American Iron & Steel) Compliant	1/2" to 3"

STANDARD MATERIAL LIST

PART	PART	MATERIAL
1	Stem packing	MPTFE
2	Stem bearing	RPTFE
3	Ball	A276-316SS (1/4" to 2", except 1-1/4") A276-316SS or A351-CF8M stainless (1-1/4") A351-CF8M stainless (3")
4	Seat (2)	RPTFE (2" & smaller); RTGM (3")
5	Retainer	ASTM A276-316SS (1/4" & 3/8") ASTM A351-CF8M stainless (1/2" to 3")
6	Gland	A276-316 Stainless Steel
7	Stem	A276-316 Stainless Steel
8	Lever nut	304 Stainless Steel
9	Body Seal	RPTFE (1/2" to 3")
10	Body	A351-CF8M
11	Lever and grip	SS w/vinyl

DIMENSIONS

PART NO.	SIZE	A	B	C	D	E	F	WT.
76F-101-01	1/4"	0.37	0.95	1.91	1.12	1.60	3.85	0.47
76F-102-01	3/8"	0.37	0.95	1.91	1.12	1.60	3.85	0.44
76F-103-01A	1/2"	0.50	1.21	2.35	1.27	1.73	3.85	0.57
76F-104-01A	3/4"	0.81	1.39	2.77	1.62	1.96	3.85	0.91
76F-105-01A	1"	1.00	1.67	3.34	2.00	2.27	4.75	1.38
76F-106-01A	1-1/4"	1.25	1.96	3.92	2.73	3.21	7.77	4.17
76F-107-01A	1-1/2"	1.50	2.05	4.10	2.92	3.31	7.77	4.69
76F-108-01A	2"	2.00	2.37	4.74	3.75	3.69	7.77	6.90
76F-100-01A	3"	3.00	3.70	7.40	5.68	5.23	10.00	22.40

Pressure/Temperature Ratings - Page M-12, Graph No. 8

*LEAD FREE: The wetted surfaces of this product shall contain no more than 0.25% lead by weighted average. Complies with Federal Public Law 111-380. ANSI 3rd party approved and listed.
 REV. 18JUL19

The listed C_v "factors" are derived from actual flow testing, at Apollo's Pageland, South Carolina factory. These tests were completed using standard "off the shelf" valves with no special preparation and utilizing standard schedule 40 pipe. It should be understood that these factors are for the valve only and also include the connection configuration. The flow testing is done utilizing water as a fluid media and is a direct statement of the gallons of water flowed per minute with a 1 psig pressure differential across the valve/connection unit. Line pressure is not a factor. Because the C_v is a factor, the formula can be used to estimate flow of most media for valve sizing.

FLOW OF LIQUID

$$Q = C_v \sqrt{\frac{\Delta P}{SpGr}}$$

$$\text{or } \Delta P = \frac{(Q)^2 (SpGr)}{(C_v)^2}$$

WHERE:

- Q = Flow in US gpm
- ΔP = Pressure drop (psig)
- SpGr = Specific gravity at flowing temperature
- C_v = Valve constant

FLOW OF GAS

$$Q = 1360 C_v \sqrt{\frac{(\Delta P) (P_2)}{(SpGr) (T)}}$$

$$\text{or } \Delta P = \frac{5.4 \times 10^{-7} (SpGr) (T) (Q)^2}{(C_v)^2 (P_2)}$$

WHERE:

- Q = Flow in SCFH
- ΔP = Pressure drop (psig)
- SpGr = Specific gravity (based on air = 1.0)
- P2 = Outlet pressure-psia (psig + 14.7)
- T = (temp. °F + 460)
- C_v = Valve constant

CAUTION: The gas equation shown, is valid at very low pressure drop ratios. The gas equation is NOT valid when the ratio of pressure drop (ΔP) to inlet pressure (P1) exceeds 0.02.

NOTE: Only use the gas equation shown if (P1-P2)/P1 is less than 0.02.

CV FACTORS FOR APOLLO VALVES (CONTINUED ON M-4)

VALVE	SIZE (IN.)														
	1/4	3/8	1/2	3/4	1	1.25	1.5	2	2.5	3	4	6	8	10	12
70B-140 Series	8.4	7.2	15	30	43	48	84	108	190	370	670	--	--	--	--
70 100/200 Series	8.4	7.2	15	30	43	48	84	108	190	370	670	--	--	--	--
70-300/400 Series	--	--	15	30	43	48	84	108	--	--	--	--	--	--	--
70-600 Series	2.3	4.5	5.4	12	14	21	34	47	--	--	--	--	--	--	--
70-800 Series	8.4	7.2	15	30	43	48	84	--	--	--	--	--	--	--	--
71-AR Series	--	--	--	30	43	48	84	108	190	370	--	--	--	--	--
71-100/200 Series	--	--	--	30	43	48	84	108	190	370	--	--	--	--	--
72-100/900 Series	--	--	26	48	65	125	170	216	--	--	--	--	--	--	--
72-1xx-A/72-9xx-A Series	--	--	26	48	65	125	170	245	--	--	--	--	--	--	--
73A-100 Series	8.4	7.2	15	30	43	48	84	108	--	--	--	--	--	--	--
73-300/400 Series	--	--	26	48	65	125	170	216	--	--	--	--	--	--	--
74-100 Series	8.4	7.2	15	30	43	48	84	108	190	370	670	--	--	--	--
75-100 Series	8.4	7.2	15	30	43	48	84	108	190	370	670	--	--	--	--
76-AR Series	8.4	7.2	15	30	43	48	84	108	190	370	670	--	--	--	--
76F-100 Series	8.1	15	15	51	68	125	177	389	--	--	--	--	--	--	--
76FJ-100 Series	8.1	15	15	51	68	125	177	389	--	--	--	--	--	--	--
76FK-100 Series	8.1	15	15	51	68	125	177	389	--	--	--	--	--	--	--
76-100 Series	8.4	7.2	15	30	43	48	84	108	190	370	--	--	--	--	--
76-300/400 Series	--	--	26	48	65	125	170	216	--	--	--	--	--	--	--
76-600 Series	2.3	4.5	5.4	12	14	21	34	47	--	--	--	--	--	--	--
76J-100 Series	8.4	7.2	15	30	43	48	84	108	190	370	--	--	--	--	--
76J-AR Series	8.4	7.2	15	30	43	48	84	108	190	370	670	--	--	--	--
76K-100 Series	8.4	7.2	15	30	43	48	84	108	190	370	--	--	--	--	--
76K-AR Series	8.4	7.2	15	30	43	48	84	108	190	370	670	--	--	--	--
7K-100 Series	--	--	15	51	68	125	177	389	503	--	--	--	--	--	--
77-AR Series	8.1	15	15	51	68	--	177	389	--	--	--	--	--	--	--

REV. 21APR17

1000 CWP

(CS) ASTM A216-WCB

GRAPH 7

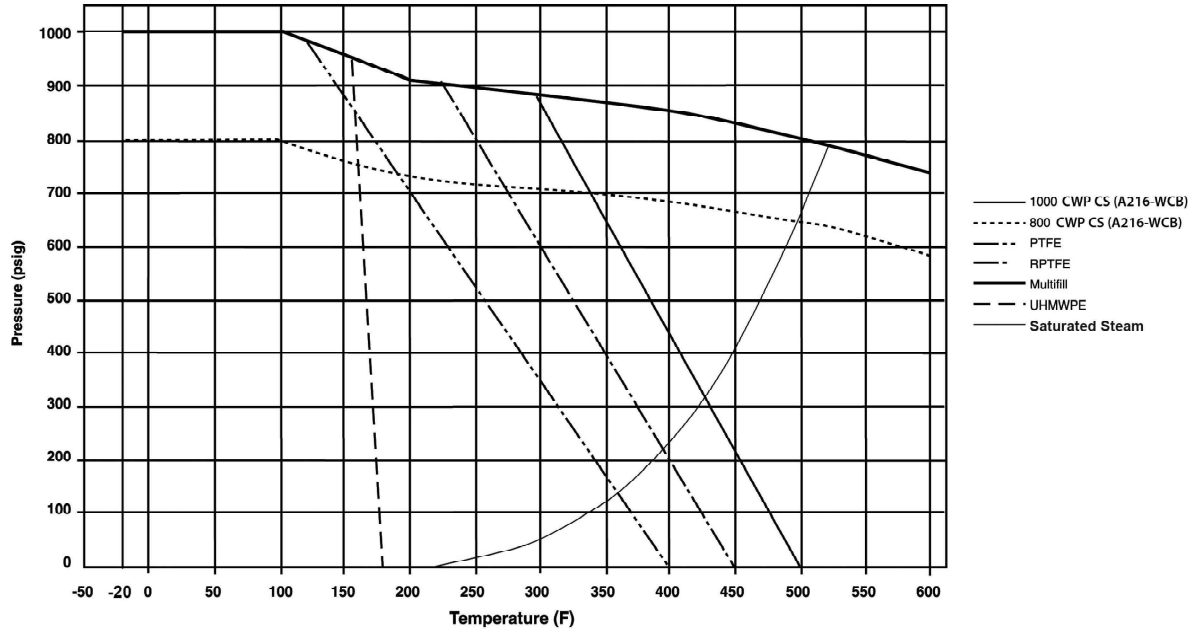

1000 CWP

(SS) ASTM A351-CF8M

GRAPH 8

