

Curbs Plus, Inc.

1200 Carline Rd.
 Rossville, GA 30741
 PH (706) 891-6629 / Fax (706) 866-2339

CPM-3 (Insulated) Metal Building Roof Curb

STANDARD FEATURES

1. 18 Ga. Prime Galvalume Steel Construction.
2. Corners Mitered and Welded Watertight.
3. Curbs Prime Painted after Fabrication.
4. Water Cricket.
5. 8" Minimum Height.
6. Internal Angle Reinforcing.
7. 1 1/2" Thick, 3# Density Fiberglass.

OPTIONS

- 1.
- 2.
- 3.
- 4.

- REVIEWED REVIEWED AS NOTED
 REJECTED REVISE & RESUBMIT

This review is only for general conformance with the design concept and the information given in the Construction Documents. Corrections or comments made on the shop drawings and submittals during this review do not relieve the contractor from compliance with the requirements of the plans and specifications and applicable laws, codes and regulations. Review of a specific item shall not include review of an assembly of which the item is a component. The contractor is responsible for: dimensions to be confirmed and correlated at the jobsite; information that pertains solely to the fabrication processes or to the means, methods, techniques, sequences and procedures of construction; coordination of the Work with that of all other trades and performing all Work in a safe and satisfactory manner.

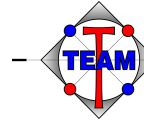

ARCHITECTURE

BY: dga
 DATE: 06-03-16

P.O. Box 43 | Andover, Kansas 67002 | (316) 347-7755 | TEAMArchitecture-LLC.com

together everyone achieves more

Note: The Front, Rear and Side Flanges Fit Over the Roof Panel

CLIPS TO MATCH THIS ROOF PANEL GULF STATES SSR

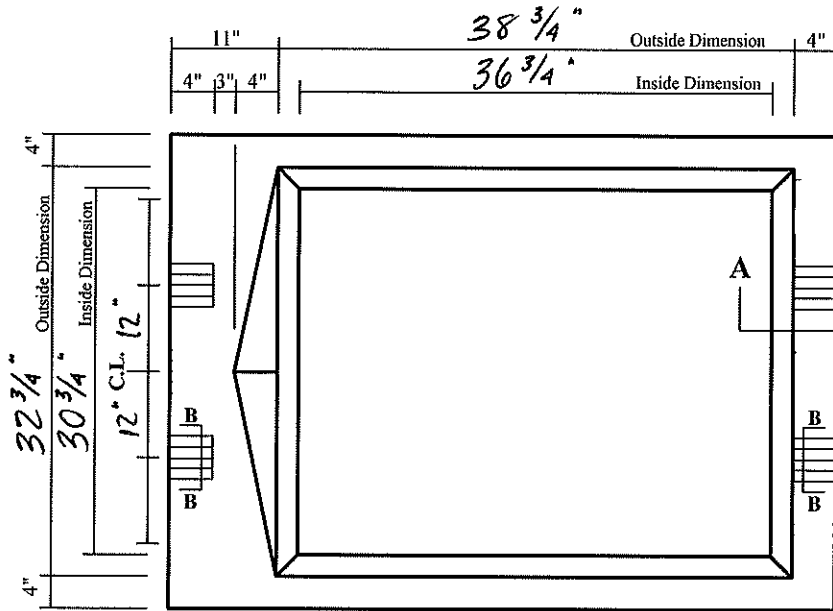

Number of Upper Clips Per Curb	<u>2</u>
Number of Lower Clips Per Curb	<u>2</u>
<input type="checkbox"/> "R" PANEL <input checked="" type="checkbox"/> "SSR" PANEL <input type="checkbox"/> "T" PANEL	
SECTION B-B	

PLAN VIEW

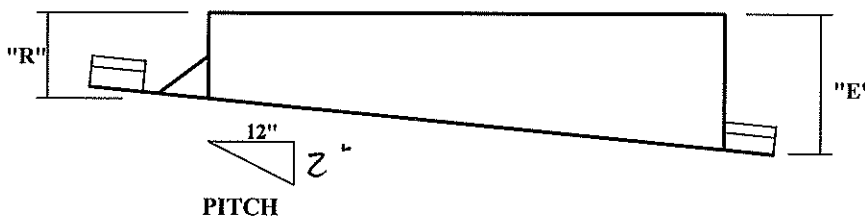

ELEVATION

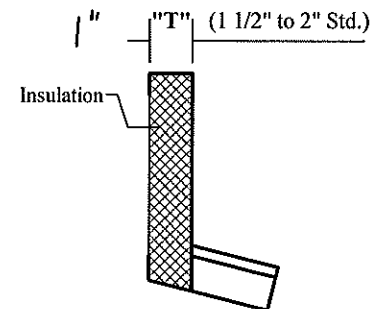

SECTION A-A

QUANTITY	INSIDE DIMENSION	OUTSIDE DIMENSION	"R"	"E"	"T"	TAG
1	30 3/4" x 36 3/4"	32 3/4" x 38 3/4"	9"	15 7/16"	1"	