



**FLUID
EQUIPMENT**
A COGENT COMPANY

**City of Wichita Re-Use Water Pump Station
Section 43 21 13 Centrifugal Liquid Pumps
June, 2015**

**Project:
City of Wichita Re-Use Water Pump Station**

Submitted to:
Wildcat Construction Co., Inc.
3219 W May
Wichita, KS 67213

Engineer:
MKEC
411 N. Webb Rd
Wichita, KS 67206

Submitted by:
Fluid Equipment
500 W. 5th Street
Kansas City, MO 64105

Date Received: _____

- A – Approved
- B – Approved as Noted
- C – Partial Approval, Resubmit as needed
- D – Revise and Resubmit
- E – For Reference/No Acceptance

500 W. 5th Street, Kansas City, MO 64105
Ph: 816.795.8511 F: 816.795.8926



Submittal Table of Contents

<u>SECTION</u>	<u>DESCRIPTION</u>
1	Turbine Data Sheet
2	Coating Data
3	Motor Data
4	General VFD and Motor Information



THIS PAGE LEFT INTENTIONALLY BLANK



Quote Number: 9001-160429-035

Fluid Equipment

May 13, 2016

Terms: FCA

Job: Wichita Re-Use Water Pump Station

We are pleased to quote you for the following equipment, subject to Xylem approval and acceptance of Xylem terms and conditions of sale. Quantities are not guaranteed and should be verified, with any Prices adjusted, prior to placing an order. This quotation is subject to change without notice and void after .

Item #	Qty	Description	Net Price USD
1	3	VIT - Short Set Lineshaft Turbine Pumps Lineshaft Turbine: Open Lineshaft, 11CMC/5-Stage, VIT-FFFM	
			2,534.00 (lb) wt.
1.1	3	Bowl Assembly 11CMC / 5-STG / Manufacturer's Standard	
			639.00 (lb) wt.
1.2	3	Column Assembly 6" x 1.19" Flanged W/L Column	
			304.00 (lb) wt.
1.3	3	Discharge Head Assembly 6" x 16.5" FF Head	
			481.00 (lb) wt.
1.4	3	Coating Themec 141; 16 mils Bowl OD Column OD and ID Head OD and ID	
			(lb) wt.
1.5	3	Driver Assembly US Motors VHS 100 HP 1800 RPM 404TP	
			1,110.00 (lb) wt.
1.6	3	Tests and Services Hydrostatic Testing (Non-Witness): Bowl Performance Testing (Non-Witness): Customer Motor, Pump	
			(lb) wt.
Total Weight (lb) (Qty. Of 3)			7,602.00

OPERATING CONDITIONS

Temp / SG	70° F / SP.GR 1.00
Fluid Type	Water
Lubrication Method	Water (Open Lineshaft)
Vapor Pressure	0.3633 psi
Viscosity	0.9695 cP
Specified Flow	700.00 USGPM
Total Dynamic Head	334.00 ft
Pumping Level	11.000 ft
TPL	0.000 ft
Sump/Pit Depth	15.000 ft
Documentation	Standard pump installation and operation manual and order data

PERFORMANCE AT 1770 RPM

Bowl Efficiency	87.50 @design, 87.80 Best Efficiency
Run Out Capacity	1188.00 USGPM
Power	67.40 @design, 76.80 NOL (Hp)
Npshr	9.01 ft @design
Design Thrust	2372.30 @design (lb)
Shut off Pressure	171.41 psi

MATERIALS AND DIMENSIONS

Bowl	Cast iron with glass enamel		
Suction Bell	Cast Iron CL30		
Bowl Wear Ring	Not Included		
Impeller	316SS		
Impeller Diameter	7.8750 inch		
Impeller Wear Ring	Not Included		
Impeller Balance	Manufacturer's Standard		
Impeller Lock Method	Taper lock	Key Material	None
Bowl Shaft	416SS, 1.6875 inch diam.		
Suction Bearing	Bronze C90300 "G" Modified		
Bowl Bearings	Bronze C90300 "G" Modified		
Rifled Drill Shaft	No		
Collets	Carbon steel		
Strainer Type	Galvanized Steel Clip On-Bell Type Strainer		
Tube Bearing Adapter Material	Not Included		
Column	Carbon Steel, 6" [152mm] (in) diam., 9.22 ft , Flanged		
Column Shaft Diameter	416SS, 1.1875 (in) diam.		
Column Bearing Retainer	304SS		
Lineshaft Bearings	Rubber EPDM		
Column Bearing Options	Not Included		
Max Bearing Space	10 ft (3 m) Spacing		
Lineshaft Coupling	416SS		

DO NOT USE FOR CONSTRUCTION UNLESS CERTIFIED

Certified by	
Date of certification	
Pump serial number	
Project Name	Wichita Re-Use Water Pump Station
Tag:	

Column Shaft Sleeve	Not Included
Tube Material	Carbon Steel
Discharge Head	Carbon Steel Fab
Discharge Head Style	FF
Discharge Flange	6" [152mm] (in), 150#
Head Shaft Coupling	CS Type AR Rigid
Steel Sub Base	Carbon Steel
150# Disch Companion Flange	Not Included
300# Disch Convenience Flange	Not Included
Head Bolting	316SS
Head Sleeve	None
Thrust Pot	Not Required
Sealing Method	Mechanical Seal
Packing	None
Mechanical Seal	John Crane 5610 XF551O58H
Sealing Features	

DRIVER INFORMATION

Motor Type	Standard
Motor Manufacturer	US Motors
Rating	100 Hp [75 kW]
Efficiency Level	PREM
Motor Part Number	EN10018P16119
Enclosure	WP1
Phase / Frequency / Volts	3 / 60 Hz / 460PWS
Speed	1800 RPM

TESTING

Hydrostatic:	Hydrostatic Testing (Non-Witness): Bowl
Performance:	Performance Testing (Non-Witness): Customer Motor, Pump
Vibration:	None
NPSH:	None
Post Inspection:	None
Final Inspection:	None
Other:	None

COATING

Coating Information:	Tnemec 141; 16 mils; Bowl Assembly - OD; Column Assembly - OD and ID; Head Assembly - OD and ID
----------------------	---

ADDITIONAL FEATURES

Additional Bowl Features

Additional Column Features

Additional Head Features:

DO NOT USE FOR CONSTRUCTION UNLESS CERTIFIED

Certified by	
Date of certification	
Pump serial number	
Project Name	Wichita Re-Use Water Pump Station
Tag:	



TURBINE SUBMITTAL

Quote Number: 9001-160429-035:1

Model: VIT-FFFM

Size: 11CMC 5 Stage(s)

Additional Driver Features:

Additional Can features:

Additional Misc features:

WEIGHTS

Total bowl weight	639 lbs
Total column weight	304 lbs
Discharge head weight	481.00 lbs
Driver weight	1110.00 lbs
Approximate net weight	2534.00 lbs

Our offer does not include specific review and incorporation of any Statutory or Regulatory Requirements and the offer is limited to the requirements of the design specifications. Should any Statutory or Regulatory requirements need to be reviewed and incorporated then the Customer is responsible to identify those and provide copies for review and revision of our offer.

Our quotation is offered in accordance with our comments and exceptions identified in our proposal and governed by our standard terms and conditions of sale – Xylem Americas attached hereafter.

For units requiring performance test, all performance tests will be conducted per ANSI/HI 14.6 standards unless otherwise noted in the selection software submittal documents. Test results meeting with grade 2B tolerances for pumps with a rated shaft power of 134HP or less and grade 1B for greater than 134HP will be considered passing.

Customer is responsible for verifying that the recommendations made and the materials selected are satisfactory for the Customer's intended environment and Customer's use of the selected pump. Customer is responsible for determining the suitability of Xylem recommendations for all operating conditions within Customer's and/or End User's control. Xylem disclaims all warranties, express or implied warranties, including, but not limited to, warranties of merchantability and fitness for a particular purpose and all express warranties other than the limited express warranty set forth in the attached standard terms and conditions of sale – Xylem Americas attached hereafter.

Xylem does not guarantee any pump intake configuration. The hydraulic and structural adequacies of these structures are the sole responsibility of the Customer or his representatives. Further, Xylem accepts no liability arising out of unsatisfactory pump intake field operating conditions.

The Customer or his representatives are referred to the Hydraulic Institute Standards for recommendations on pump intake design. To optimize the hydraulic design of a field pump intake configuration, the Customer should strongly consider performing a detailed scale model pump intake study. However, the adequacies of these recommendations are the sole responsibility of the Customer.

DO NOT USE FOR CONSTRUCTION UNLESS CERTIFIED

Certified by	
Date of certification	
Pump serial number	
Project Name	Wichita Re-Use Water Pump Station
Tag:	

OVERALL PUMP PARAMETERS

Capacity:	700.00 USGPM	Total Dynamic Head:	334.00 ft
Total Pump Length:	0.000 ft	Impeller Trim:	7.8750 inch
Pump Type:	VIT - Short Set Lineshaft Turbine Pumps	Head Type:	Type FF (Fabricated F-Head)
Pump K-Factor:	7.0000 lbs/ft	Number of Stages:	5
Additional Pump K-Factor:	7.0000 lbs/ft	Pumping Level:	11.000 ft
Pump Operating Speed [RPM]:	1770		

LINE SHAFT RELATED DATA

Shaft Diameter:	1.1875 inch	Shaft Limit :	125 Hp
Shaft Material:	416SS	Material Correction Fact:	1.18
Line Shaft Length:	110.65 inch	Shaft Elongation:	0.00802 inch
Line Shaft Type:	Water (Open Lineshaft)	Impeller Running Clearance:	0.13 inch

BOWL DATA

Total Bowl Length:	61.35 inch	Bowl Shaft Limit:	371 Hp
Bowl Shaft Diameter:	1.6875 inch	Bowl Shaft Material:	416SS
Bowl Diameter:	11.000 inch		

COLUMN DATA

Column Diameter:	6 inch	Column Elongation:	0.00024 inch
Column Wall Thickness:	0.280 inch	Shut Off Column Elongation:	0.00033 inch
Column Load:	442.20 lb		

HORSEPOWER DATA

Shaft Friction Loss:	0.06678 Hp	Thrust Load Loss:	0.33139 Hp
Bowl Hp at Design:	67 Hp	Rating:	100 Hp [75 kW]

OTHER DATA

Hydraulic Thrust:	2337.80 lb	Thrust at Design:	2372.30 lb
Thrust at Shut Off:	2781.49 lb	Actual Head Above Grade:	321.17 ft
Available Lateral:	0.88 inch	Design Lateral:	0.13778 inch
Shut Off Lateral:	0.13872 inch		
Suction Head:	0.00 ft	Shut Off Discharge Pressure:	171.41 psi
Column Loss:	0.58 ft	NPSHa:	32.59 ft
Head Loss:	1.25 ft	NPSHr:	9.01 ft @design
Total Loss:	1.83 ft	NPSH Margin:	2.00 ft

EFFICIENCY DATA

Bowl Efficiency:	87.80 %	Overall Efficiency:	0.00 %
Motor Efficiency:	0.00 %	KWH per 1000 gallons:	0.00
Pump Efficiency:	86.50 %		

FLUID DATA

Fluid Type:	Water	Specific Gravity:	0.9999
Temperature:	70°F	Viscosity:	0.9695 cP

COMPONENT WEIGHTS

Bowl Weight:	639 lbs	Column Weight:	304 lbs
Head Weight:	481 lbs	Can Weight:	0 lbs
Driver Weight:	1110 lbs	Total Pump Weight:	2534 lbs

DO NOT USE FOR CONSTRUCTION UNLESS CERTIFIED

Certified by	
Date of certification	
Pump serial number	
Project Name	Wichita Re-Use Water Pump Station
Tag	

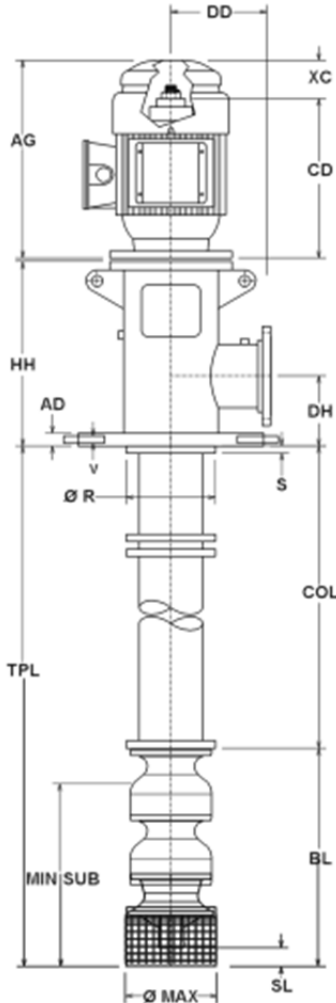
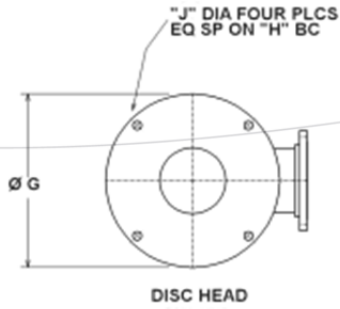

DIMENSIONS

AD	1.38	inch
AG	42.69	inch
BD	16.5	inch
BL	61.35	inch
CD	36.94	inch
CL	0.00	inch
COL	110.64	inch
DD	15.00	inch
MIN SUB	23.68	inch
DH	8.50	inch
G	19.00	inch
H	17.00	inch
HH	37.50	inch
J	1.00	inch
L	0.00	inch
M		
R	10.00	inch
S	1.81	inch
SL	1.01	inch
SU	0.00	inch
SUT	0.00	inch
TUBE	0.00	inch
TPL	0.00	inch
UG	0.00	inch
V	1.00	inch
W	19.00	inch
X	16.00	inch
XC	5.75	inch
Y	1.00	inch
Z	14.00	inch
Max Dia	12.13	inch
Discharge	(150 #) 6" [152mm]	inch
Suction	(150 #) 8	inch

PUMP DATA

No. of Units	1.00
Model:	VIT-FFFM 11CMC
Stages:	5
Col Size:	6" [152mm]
Shaft:	1.1875 in dia
Flow:	700.00 USGPM
Head:	334.00 ft
Driver Mfr:	US Motors
Driver Type:	VHS
Rating:	100 Hp [75 kW]
Speed:	1800 RPM
Phase:	3
Frequency:	60 Hz
Voltage:	460PWS

No.	NOTES
1	Total Pump Length ± 1.0 inch.
2	Tolerance on all dimensions is .12 or ± .12 inch per 5 ft, whichever is greater.
3	All dimensions shown are in inches unless otherwise specified.
4	Drawing not to scale.
5	½" NPT – Gauge Conn (plugged)
6	Driver may be rotated at 90° intervals about vertical centerline for details refer to driver dimension drawing.
7	Before starting pump, impeller must be lifted 0.19 inch.
8	This assembly has been designed so that its natural frequency responses avoid the specific operating speeds by an adequate safety margin. The design has assumed the foundation to be rigid.

Weights

Total bowl	639.00	lb
Total column	304	lb
Discharge head	481.00	lb
Driver	1110.00	lb
Approx weight	2534.00	lb

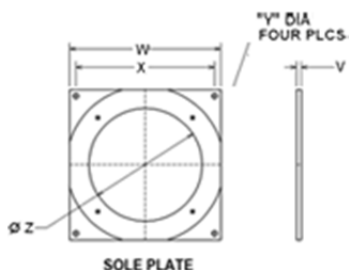

DO NOT USE FOR CONSTRUCTION UNLESS CERTIFIED

Certified by	
Date of certification	
Pump serial number	
Project Name	Wichita Re-Use Water Pump Station
Tag	

BILL OF MATERIAL

ITEM	Part Name	CODE	MATERIAL	ASTM#
Discharge Head Assembly				
600	Head – Discharge	9645	Carbon Steel Fab	A53
602	Head – Base Plate	3201	Carbon Steel	A36M-00a
604	Nut – Adjusting	2242	Carbon Steel 1018	A108-99
608	Headshaft	2227	416SS	A582M-95b
616	Housing	1003	Cast Iron CL30	A48-94-a#1
617	Bearing-Housing	1109	Bronze C90300 "G" Modified	B584-00
626	Seal	0000	John Crane 5610 XF551O58H	
730	Key – Motor GIB	2242	Carbon Steel 1018	A108-99
779	Gasket – Housing	5136	Acrylic/Nitrile	5136 Rev 4
Column and Lineshaft Assembly				
637	Hanger Flange	N/A	Not Included	N/A
642	Column Pipe	9645	Carbon Steel	A53
645	Column-Coupling	N/A	Not Applicable	N/A
646	Lineshaft	2227	416SS	A582M-95b
649	Lineshaft Coupling	2265	416SS	A582M-95b
652	Retainer-Bearing	1205	304SS	A744M-00
656	Lineshaft Bearing	5121	Rubber EPDM	D3568-98
760	Capscrew-Hex	2229	316SS	A276-00a
Bowl Assembly				
660	Bowl-Shaft	2227	416SS	A582M-95b
664	Bearing – Disc Bowl	N/A	None	N/A
670	Bowl-Inter	6911	Cast Iron CL30 Enamel	A48-94e1
672	Bearing-Int Bowl	1109	Bronze C90300 "G" Modified	B584-00
673	Impeller	1203	316SS	A744M-00
677	Collet-Impeller	2242	Carbon steel	A108-99
674	Key-Impeller	N/A	None	N/A
680	Wear Ring-Bowl	N/A	Not Included	N/A
681	Wear Ring-Impeller	N/A	Not Included	N/A
688	Bell-Suction	690	Cast Iron CL30	1003
690	Bearing-Suction	1109	Bronze C90300 "G" Modified	B584-00
692	Sandcollar	1205	304SS	A744M-00
698	Clip On-Bell Type Strainer	6952	Galvanized Steel	A123
747	Plug-Pipe	1046	Malleable Iron	A197
760	Capscrew-Hex	2229	316SS	A276-00a

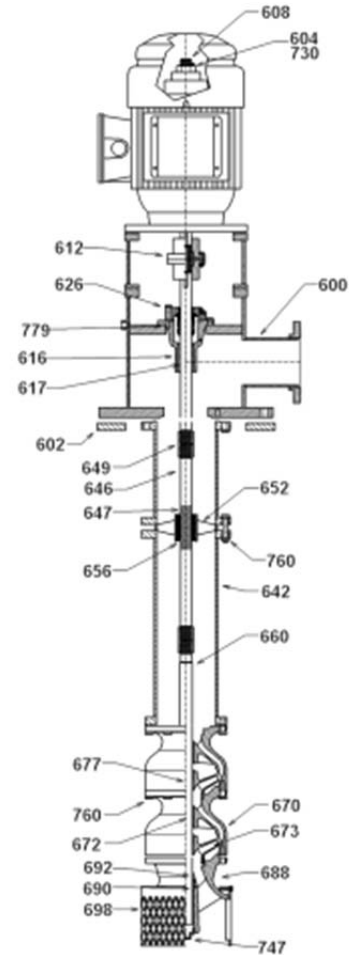

DO NOT USE FOR CONSTRUCTION UNLESS CERTIFIED

Certified by	
Date of certification	
Pump serial number	
Project Name	Wichita Re-Use Water Pump Station
Tag	

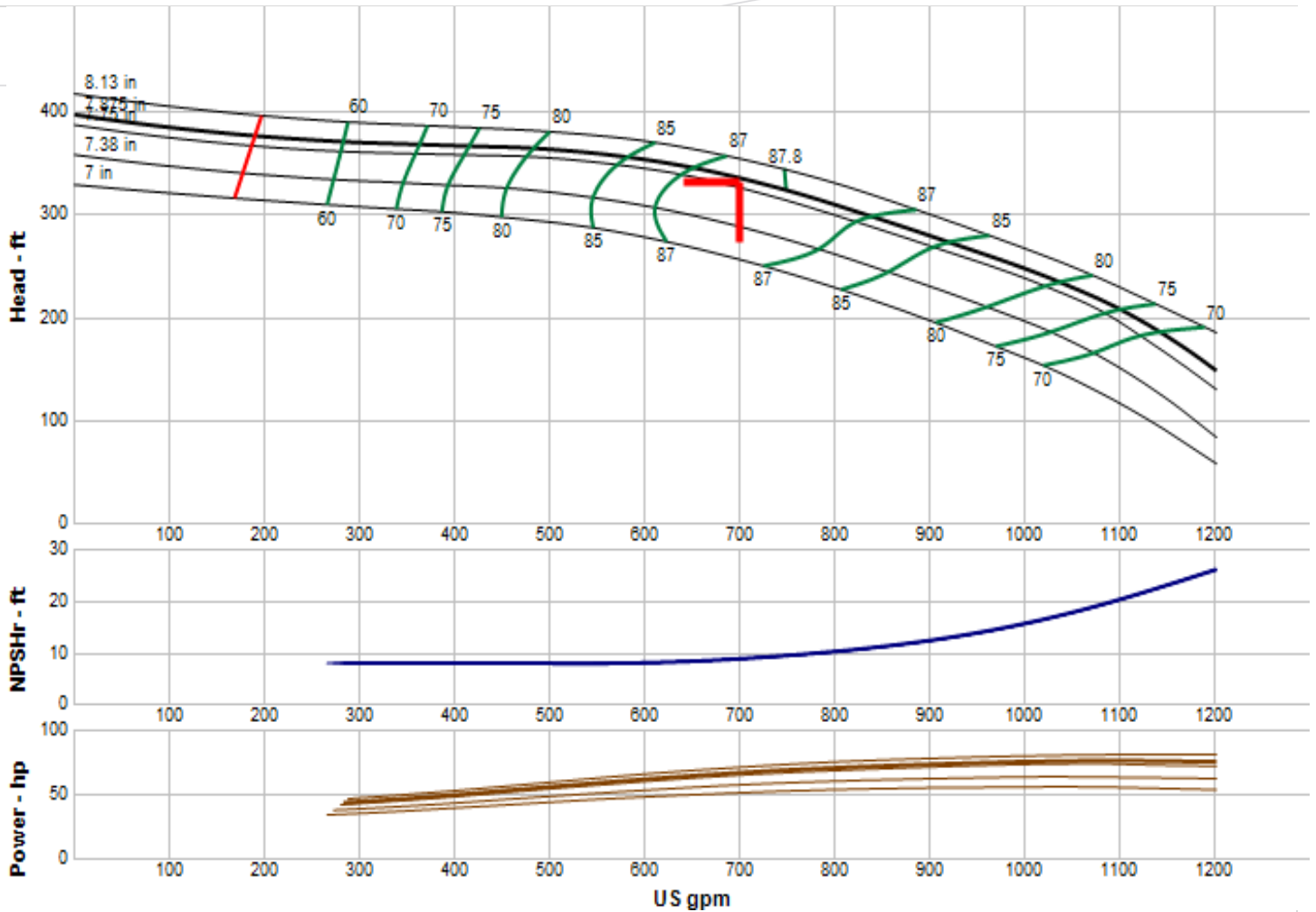

Driver Size Criteria:	Max power on design curve (NOL)	Best Efficiency:	87.80 %
Speed:	1770	Flow at BEP:	748.00 USGPM
Impeller Trim:	7.8750 inch	Min Flow:	187.00 USGPM
Frequency:	60 Hz	Derate Factor:	0.0000
Additional Impeller Trim:	7.875 inch	NPSH Required:	9.01 ft
Impeller Maximum Trim:	8.1300 inch	Specified NPSH Avail:	34.00 ft
Specified Flow:	700.00 USGPM	Shut-Off Head:	396.00 ft
Specified Head:	330.00 ft	Fluid Type:	Water
Head at Design:	334.00 ft	Temperature / Specific Gravity:	70°F / 1.00
Efficiency at Design:	87.50 %	Viscosity:	0.9695 cP
Power at Design:	67.40 Hp	Allowable Sphere Size:	0.88 inch
Flow on Design Trim at Max Power:	1099 USGPM	Thrust K Factor:	7.0000 lbs/ft
Max Power on Design Curve:	76.80 Hp	Additional Thrust K Factor:	7.0000 lbs/ft
Run-Out Flow:	0.00 USGPM	Max Lateral:	0.88 inch
Run-Out Head:	0 ft		

DO NOT USE FOR CONSTRUCTION UNLESS CERTIFIED

Certified by	
Date of certification	
Pump serial number	
Project Name	Wichita Re-Use Water Pump Station
Tag	



PRODUCT PROFILE

- GENERIC DESCRIPTION** Modified Polyamine Epoxy
- COMMON USAGE** High solids coating which offers high-build edge protection and excellent corrosion resistance. For use on the interior and exterior of steel or concrete tanks, reservoirs, pipes, valves, pumps, and equipment, as well as other steel and concrete substrates.
- COLORS** Available in the following standard industrial colors: 1211 Red, 1253 Gray, 1255 Beige, 1256 Blue and 35GR Black. **Note:** Epoxies chalk with extended exposure to sunlight. Lack of ventilation, incomplete mixing, miscatalyzation or the use of heaters that emit carbon dioxide and carbon monoxide during application and initial stages of curing may cause yellowing to occur. **Important: Due to the product's curing agent chemistry, color variations can be pronounced. However, these changes in color are aesthetic only and will not affect performance or certifications. Contact your Tnemec representative for more information.**
- SPECIAL QUALIFICATIONS** Certified by **NSF International** in accordance with **NSF/ANSI Std. 61**. Seven day ambient air cured Series 141 is qualified for use on tanks and reservoirs of 500 gallons (1893 L) capacity and greater, pipes 22 inches (56 cm) in diameter and greater, fittings 1 inch (2.54 cm) in diameter and greater, valves 4 inches (10 cm) in diameter and greater, and pumps 4 inches (10 cm) in diameter and greater. When cured for 30 days at ambient air temperature, Series 141 is qualified for use on pipes 10 inches (25.4 cm) in diameter and greater, fittings 3/4 inch (1.9 cm) in diameter and greater, valves 2 1/2 inches (6.35 cm) in diameter and greater, and pumps 4 inches (10 cm) in diameter and greater. Reference the "Search Listings" section of the NSF website at www.nsf.org for details on the maximum allowable DFT, certified colors, and primer and topcoat compatibility for use in potable water.
- PERFORMANCE CRITERIA** Extensive test data available. Contact your Tnemec representative for specific test results.

COATING SYSTEM

- PRIMERS** **Steel:** Self-priming, 1, 20, FC20, 27, 27WB, 37H, L69, L69F, N69, N69F, V69, V69F, 90E-92, 90G-1K97, 90-97, H90-97, 90G-98, 91-H₂O, H91-H₂O, 94-H₂O, 135, L140, L140F, N140, N140F, V140, V140F, 394, 530
Concrete: Self-priming, 20, FC20, 27, 27WB, L69, L69F, N69, N69F, V69, V69F, L140, L140F, N140, N140F, V140, V140F, 215, 217, 218
CMU: Self-priming or Series 130, 215, 218, 1254
- TOPCOATS** **Exterior:** Series 73, 180, 1028, 1029, 1074, 1074U, 1075, 1075U. **Note:** The following maximum recoat time applies when using Series 73, 180, 1074, 1074U, 1075, or 1075U: fourteen (14) days. If this time limit is exceeded, Series 141 must be uniformly scarified prior to topcoating.

SURFACE PREPARATION

- PRIMED STEEL** **Immersion Service:** Scarify the Series 20, FC20, L69, L69F, N69, N69F, V69, V69F, L140, L140F, N140, N140F, V140 or V140F prime coat surface by brush-blasting with fine abrasive before topcoating if it has been exterior exposed for 30 days or longer and 141 is the specified topcoat.
- STEEL** **Immersion Service:** SSPC-SP10/NACE 2 Near-White Blast Cleaning with a minimum angular anchor profile of 2.0 mils
Non-Immersion Service: SSPC-SP6/NACE 3 Commercial Blast Cleaning with a minimum angular anchor profile of 2.0 mils. **Note:** Abrasive blast cleaning generally produces the best coating performance. If conditions will not permit this, Series 141 may be applied to SSPC-SP2 or SP3 Hand or Power Tool Cleaned surfaces.
- CONCRETE** Allow new cast-in-place concrete to cure a minimum of 28 days at 75°F (24°C). Verify concrete dryness in accordance with ASTM F 1869 "Standard Test Method for Measuring Moisture Vapor Emission Rate of Concrete Subfloor Using Anhydrous Calcium Chloride" (moisture vapor transmission should not exceed three pounds per 1,000 square feet in a 24 hour period), F 2170 "Standard Test Method for Determining Relative Humidity in Concrete using in situ Probes" (relative humidity should not exceed 80%), or D 4263 "Standard Test Method for Indicating Moisture in Concrete by the Plastic Sheet Method" (no moisture present). Prepare concrete surfaces in accordance with NACE No. 6/SSPC-SP13 Joint Surface Preparation Standards and ICRI Technical Guidelines. Abrasive blast, shot-blast, water jet or mechanically abrade concrete surfaces to remove laitance, curing compounds, hardeners, sealers and other contaminants and to provide a minimum ICRI-CSP 3 surface profile. Large cracks, voids and other surface imperfections should be filled with a recommended filler or surfacer.
- ALL SURFACES** Must be clean, dry and free of oil, grease, chalk and other contaminants.

TECHNICAL DATA

- VOLUME SOLIDS** 82% ± 2.0% (mixed) †
- RECOMMENDED DFT** 4.0 to 18.0 mils (100 to 455 microns) in a one coat application. **Note:** Thickness requirements will vary with substrate, application method and exposure. Contact your Tnemec representative. Maximum dry film thickness for NSF exposure is 18.0 mils.

CURING TIME AT 5 MILS DFT

Temperature	To Handle	To Topcoat	Immersion
90°F (32°C)	3 hours	4 hours ‡	7 days
75°F (24°C)	4 hours	5 hours ‡	7 days
65°F (18°C)	7 hours	9 hours ‡	8 days
55°F (13°C)	13 hours	18 hours ‡	9 days
45°F (7°C)	20 hours	24 hours ‡	13 days
40°F (4°C)	22 hours	28 hours ‡	18 days
35°F (0°C)	64 hours	72 hours ‡	30 days

Curing time varies with surface temperature, air movement, humidity and film thickness.

‡ **Note:** Specific application requirements, including cure schedules and environmental conditions, must be followed when topcoating Series 141. Contact Tnemec Technical Service for detailed instructions. **Note:** Maximum recoat time with itself is seven days. **Note:** For one-coat pipe and valve applications, allow 30 days cure at 75°F (24°C) prior to immersion. Refer to product listing on www.NSF.org for specific potable water return to service information.

EPOXOLINE® | SERIES 141

VOLATILE ORGANIC COMPOUNDS

EPA Method 24
Unthinned: 0.90 lbs/gallon (107 grams/litre)
Thinned 5% (No. 60 Thinner): 1.21 lbs/gallon (145 grams/litre)
Thinned 10% (No. 4 Thinner): 1.45 lbs/gallon (173 grams/litre) †

HAPS
THEORETICAL COVERAGE
NUMBER OF COMPONENTS
MIXING RATIO
PACKAGING

Unthinned: 1.27 lbs/gal solids **Thinned 5% (No. 60):** 1.28 lbs/gal solids **Thinned 10% (No. 4):** 1.95 lbs/gal solids
 1,315 mil sq ft/gal (32.2 m²/L at 25 microns). See APPLICATION for coverage rates. †

Two: Part A (amine) and Part B (epoxy)

By volume: Two (Part A) to one (Part B)

	PART A (Partially Filled)	PART B (Partially Filled)	When Mixed
Large Kit	1-6 gallon pail	1-3 gallon pail	5 gallons
Small Kit	1-1 gallon can	1-1 gallon can	1 gallon

NET WEIGHT PER GALLON
STORAGE TEMPERATURE

13.33 ± 0.25 lbs (6.05 ± .11 kg) †

Minimum 20°F (-7°C) Maximum 110°F (43°C)
 Prior to application, the material temperature should be above 60°F (16°C). It is suggested the material be stored at this temperature at least 48 hours prior to use.

TEMPERATURE RESISTANCE
SHELF LIFE
FLASH POINT - SETA
HEALTH & SAFETY

(Dry) Continuous 250°F (121°C) Intermittent 275°F (135°C)

12 months at recommended storage temperature.

Part A: 91°F (33°C) Part B: 111°F (44°C)

This product contains chemical ingredients which are considered hazardous. Read container label warning and Material Safety Data Sheet for important health and safety information prior to the use of this product.
Keep out of the reach of children.

APPLICATION

COVERAGE RATES

	Dry Mils (Microns)	Wet Mils (Microns)	Sq Ft/Gal (m ² /Gal)
Minimum	4.0 (100)	5.0 (125)	329 (30.5)
Maximum	18.0 (455)	22.0 (560)	73 (6.8)

Note: Maximum of 18.0 mils DFT in one coat. **Maximum total dry film thickness for NSF exposure is 18.0 mils.** Allow for overspray and surface irregularities. Wet film thickness is rounded to the nearest 0.5 mil or 5 microns. Application of coating below minimum or above maximum recommended dry film thicknesses may adversely affect coating performance. Reference the "Search Listings" section of the NSF website at www.nsf.org for details on the maximum allowable DFT. †

MIXING

Mix the entire contents of Part A and Part B separately. Scrape all of the Part B into the Part A pail by using a flexible spatula. Use a variable speed drill with a PS Jiffy blade and mix the blended components for a minimum of two minutes. Apply the mixed material within pot life limits after agitation. Both components must be above 50°F (10°C) prior to mixing. For optimum application properties, the material temperature should be above 60°F (16°C). For applications to surfaces between 35°F to 50°F (2°C to 10°C) allow mixed material to stand 30 minutes and restir before use. **Note:** A large volume of material will set up quickly if not applied or lessened in mass. **Caution: Do not reseal mixed material. An explosion hazard may be created.**

THINNING

Caution: Do not add thinner to Part A prior to mixing with Part B. For airless spray, brush or roller, thin up to 5% per gallon with No. 4 Thinner or No. 60 Thinner. For air spray, thin up to 10% per gallon with No. 4 or No. 60 Thinner.

POT LIFE

2 hours at 77°F (21°C) 1 hour at 90°F (32°C)

SPRAY LIFE

1 hour at 77°F (21°C) 30 minutes at 90°F (32°C)

APPLICATION EQUIPMENT

Air Spray

Gun	Fluid Tip	Air Cap	Air Hose ID	Mat'l Hose ID	Atomizing Pressure	Pot Pressure
DeVilbiss JGA	E	765 or 704	5/16" or 3/8" (7.9 or 9.5 mm)	3/8" or 1/2" (9.5 or 12.7 mm)	75-100 psi (5.2-6.9 bar)	10-20 psi (0.7-1.4 bar)

Low temperatures or longer hoses require higher pot pressure.

Airless Spray

Tip Orifice	Atomizing Pressure	Mat'l Hose ID	Manifold Filter
0.017"-0.021" (430-535 microns)	3000-3800 psi (207-262 bar)	1/4" or 3/8" (6.4 or 9.5 mm)	60 mesh (250 microns)

Use appropriate tip/atomizing pressure for equipment, applicator technique and weather conditions.

Roller: Roller application optional when environmental restrictions do not allow spraying. Use 3/8" or 1/2" (9.5 mm to 12.7 mm) synthetic woven nap covers.

Brush: Recommended for small areas only. Use high quality natural or synthetic bristle brushes.

SURFACE TEMPERATURE

Minimum 35°F (2°C) Maximum 135°F (57°C).
 The surface should be dry and at least 5°F (3°C) above the dew point. Coating will not cure below minimum surface temperature.

CLEANUP

Flush and clean all equipment immediately after use with the recommended thinner or MEK.
 † Values may vary with color.

EPOXOLINE® | SERIES 141

WARRANTY & LIMITATION OF SELLER'S LIABILITY: Tnemec Company, Inc. warrants only that its coatings represented herein meet the formulation standards of Tnemec Company, Inc. THE WARRANTY DESCRIBED IN THE ABOVE PARAGRAPH SHALL BE IN LIEU OF ANY OTHER WARRANTY, EXPRESSED OR IMPLIED, INCLUDING BUT NOT LIMITED TO, ANY IMPLIED WARRANTY OF MERCHANTABILITY OR FITNESS FOR A PARTICULAR PURPOSE. THERE ARE NO WARRANTIES THAT EXTEND BEYOND THE DESCRIPTION ON THE FACE HEREOF. The buyer's sole and exclusive remedy against Tnemec Company, Inc. shall be for replacement of the product in the event a defective condition of the product should be found to exist and the exclusive remedy shall not have failed its essential purpose as long as Tnemec is willing to provide comparable replacement product to the buyer. NO OTHER REMEDY (INCLUDING, BUT NOT LIMITED TO, INCIDENTAL OR CONSEQUENTIAL DAMAGES FOR LOST PROFITS, LOST SALES, INJURY TO PERSON OR PROPERTY, ENVIRONMENTAL INJURIES OR ANY OTHER INCIDENTAL OR CONSEQUENTIAL LOSS) SHALL BE AVAILABLE TO THE BUYER. Technical and application information herein is provided for the purpose of establishing a general profile of the coating and proper coating application procedures. Test performance results were obtained in a controlled environment and Tnemec Company makes no claim that these tests or any other tests, accurately represent all environments. As application, environmental and design factors can vary significantly, due care should be exercised in the selection and use of the coating.

NAMEPLATE DATA

CATALOG NUMBER: <input style="width: 150px;" type="text" value="HO100V2SLG"/>		NAMEPLATE PART #: <input style="width: 150px;" type="text" value="422707-005"/>	
MODEL <input style="width: 80px;" type="text" value="DT79"/>	FR <input style="width: 80px;" type="text" value="404TP"/>	TYPE <input style="width: 80px;" type="text" value="RUSI"/>	ENCL <input style="width: 80px;" type="text" value="WPI"/>
SHAFT END BRG <input style="width: 150px;" type="text" value="6212-J - QTY 1"/>		OPP END BRG <input style="width: 150px;" type="text" value="7222 BEM - QTY 1"/>	
PH <input style="width: 40px;" type="text" value="3"/>	MAX AMB <input style="width: 60px;" type="text" value="40 C"/>	ID# <input style="width: 150px;" type="text"/>	
INSUL CLASS <input style="width: 40px;" type="text" value="F"/>	Asm. Pos. <input style="width: 150px;" type="text"/>	DUTY <input style="width: 150px;" type="text" value="CONT"/>	
HP <input style="width: 40px;" type="text" value="100"/>	RPM <input style="width: 60px;" type="text" value="1785"/>	HP <input style="width: 40px;" type="text"/>	RPM <input style="width: 60px;" type="text"/>
VOLTS <input style="width: 60px;" type="text" value="460"/>		VOLTS <input style="width: 60px;" type="text"/>	
FL AMPS <input style="width: 60px;" type="text" value="114.0"/>		FL AMPS <input style="width: 60px;" type="text"/>	
SF AMPS <input style="width: 60px;" type="text" value="131.0"/>		SF AMPS <input style="width: 60px;" type="text"/>	
SF <input style="width: 40px;" type="text" value="1.15"/>	DESIGN <input style="width: 40px;" type="text" value="B"/>	CODE <input style="width: 40px;" type="text" value="G"/>	
NEMA NOM EFFICIENCY <input style="width: 60px;" type="text" value="95.4"/>	NOM PF <input style="width: 60px;" type="text" value="86.3"/>	KiloWatt <input style="width: 60px;" type="text" value="74.6"/>	
GUARANTEED EFFICIENCY <input style="width: 60px;" type="text" value="94.5"/>	MAX KVAR <input style="width: 60px;" type="text"/>	HZ <input style="width: 40px;" type="text" value="60"/>	

HAZARDOUS LOCATION DATA (IF APPLICABLE):

DIVISION <input style="width: 100px;" type="text"/>	CLASS I <input style="width: 100px;" type="text"/>	GROUP I <input style="width: 100px;" type="text"/>
TEMP CODE <input style="width: 100px;" type="text"/>	CLASS II <input style="width: 100px;" type="text"/>	GROUP II <input style="width: 100px;" type="text"/>

VFD DATA (IF APPLICABLE):

VOLTS <input style="width: 100px;" type="text" value="460"/>	
AMPS <input style="width: 100px;" type="text" value="119.7"/>	
TORQUE 1 <input style="width: 150px;" type="text" value="294.3LB-FT"/>	TORQUE 2 <input style="width: 150px;" type="text"/>
VFD LOAD TYPE 1 <input style="width: 150px;" type="text" value="VT/PWM"/>	VFD LOAD TYPE 2 <input style="width: 150px;" type="text"/>
VFD HERTZ RANGE 1 <input style="width: 100px;" type="text" value="6-60"/>	VFD HERTZ RANGE 2 <input style="width: 100px;" type="text"/>
VFD SPEED RANGE 1 <input style="width: 100px;" type="text" value="180-1800"/>	VFD SPEED RANGE 2 <input style="width: 100px;" type="text"/>
SERVICE FACTOR <input style="width: 100px;" type="text" value="1.00"/>	FL SLIP <input style="width: 100px;" type="text"/>
NO. POLES <input style="width: 100px;" type="text"/>	MAGNETIZING AMPS <input style="width: 100px;" type="text"/>
VECTOR MAX RPM <input style="width: 100px;" type="text"/>	Encoder PPR <input style="width: 100px;" type="text"/>
Radians / Seconds <input style="width: 100px;" type="text"/>	Encoder Volts <input style="width: 100px;" type="text"/>

TEAO DATA (IF APPLICABLE):

HP (AIR OVER) <input style="width: 100px;" type="text"/>	HP (AIR OVER M/S) <input style="width: 100px;" type="text"/>	RPM (AIR OVER) <input style="width: 100px;" type="text"/>	RPM (AIR OVER M/S) <input style="width: 100px;" type="text"/>
FPM AIR VELOCITY <input style="width: 100px;" type="text"/>	FPM AIR VELOCITY M/S <input style="width: 100px;" type="text"/>	FPM AIR VELOCITY SEC <input style="width: 100px;" type="text"/>	

ADDITIONAL NAMEPLATE DATA:

Decal / Plate	WD=165975,CP=132839	Customer PN	
Notes		Non Rev Ratchet	NRR
Max Temp Rise		OPP/Upper Oil Cap	5 QT/4.7 L
Thermal (WDG)	OVER TEMP PROT 2	SHAFT/Lower Oil Cap	GREASE
Altitude			
Regulatory Notes		Regulatory Compliance	
COS		Marine Duty	
Balance	0.08 IN/SEC	Arctic Duty	
3/4 Load Eff.	95.5	Inrush Limit	
Motor Weight (LBS)	1110	Direction of Rotation	
Sound Level		Special Note 1	
Vertical Thrust (LBS)	6700	Special Note 2	
Thrust Percentage	100% HT	Special Note 3	
Bearing Life		Special Note 4	
Starting Method		Special Note 5	
Number of Starts		Special Note 6	
200/208V 60Hz Max Amps		SH Max. Temp.	
190V 50 hz Max Amps		SH Voltage	SH VOLTS=115V
380V 50 Hz Max Amps		SH Watts	SH WATTS=144W
NEMA Inertia		Load Inertia	
Sumpheater Voltage		Sumpheater Wattage	
Special Accessory Note 1		Special Accessory Note 16	
Special Accessory Note 2		Special Accessory Note 17	
Special Accessory Note 3		Special Accessory Note 18	
Special Accessory Note 4		Special Accessory Note 19	
Special Accessory Note 5		Special Accessory Note 20	
Special Accessory Note 6		Special Accessory Note 21	
Special Accessory Note 7		Special Accessory Note 22	
Special Accessory Note 8		Special Accessory Note 23	
Special Accessory Note 9		Special Accessory Note 24	
Special Accessory Note 10		Special Accessory Note 25	
Special Accessory Note 11		Special Accessory Note 26	
Special Accessory Note 12		Special Accessory Note 27	
Special Accessory Note 13		Special Accessory Note 28	
Special Accessory Note 14		Special Accessory Note 29	
Special Accessory Note 15		Special Accessory Note 30	
Heater in C/B Voltage		Heater in C/B Watts	
Zone 2 Group		Division 2 Service Factor	
Note 1		Note 2	
Note 3			

NIDEC MOTOR CORPORATION
ST. LOUIS, MO



TYPICAL NAMEPLATE DATA
ACTUAL MOTOR NAMEPLATE LAYOUT MAY VARY
SOME FIELDS MAY BE OMITTED

Nidec trademarks followed by the ® symbol are registered with the U.S. Patent and Trademark Office.

NIDEC MOTOR CORPORATION8050 WEST FLORISSANT AVE.
ST. LOUIS, MO 63136**DATE:** 6/10/2016**P.O. NO.:** DT79
Order/Line
NO.: 22206 MN 100**TO:****Model Number:** DT79
Catalog Number: HO100V2SLG
VHS Weather Protected
CONF,MOTOR,VHS WPI**REVISIONS:**
(NONE)**ALL DOCUMENTS HEREIN ARE CONSIDERED CERTIFIED BY NIDEC MOTOR CORPORATION.****THANK YOU FOR YOUR ORDER AND THE OPPORTUNITY TO SERVE YOU.****Features:**

Horsepower 00100.00~00000.00 ~ KW: 74.6
 Enclosure WPI
 Poles 04~00 ~ RPM: 1800~0
 Frame Size 404~TP
 Phase/Frequency/Voltage.. 3~060~460 ~ Random Wound
 Service Factor 1.15
 Insulation Class Class "F" ~ Insulife 2000
 Altitude In Feet (Max) .. 3300 Ft.(1000 M) ~ +40 C
 Efficiency Class Premium Efficiency
 Application Vertical Centrifugal Pump
 Customer Part Number
 16.5" Base ~ Coupling Size: 1-1/2" Bore, 3/8" Key
 Non-Reverse Ratchet ~ Steady Bushing Not Requested
 Pricebook Thrust Value (lbs).. 6700
 Customer Down Thrust (lbs) ... 6700
 Customer Shutoff Thrust (lbs).
 Up Thrust (lbs): ~
 Inverter Duty Rating:
 Load Type (Base Hz & Below) .. Variable Torque
 Speed Range (Base Hz & Below). 10:1
 Temperature Rise (Sine Wave): "F" Rise @ SF (Resist)
 Starting Method PWS (Dual Volt-Low Volt Only)
 Duty Cycle Continuous Duty
 Efficiency Value 95.4 % ~ Typical
 Load Inertia (lb-ft²): NEMA ~ NEMA Inertia: 441.00 ~ 1.00
 Number Of Starts Per Hour: NEMA
 Motor Type Code RUSI
 Rotor Inertia (LB-FT²) 17.0 LB-FT²
 Qty. of Bearings PE (Shaft) 1
 Qty. of Bearings SE (OPP) 1
 Bearing Number PE (Shaft) 6212-J
 Bearing Number SE (OPP) 7222 BEM

Nidec trademarks followed by the ® symbol are registered with the U.S. Patent and Trademark Office.

NIDEC MOTOR CORPORATION8050 WEST FLORISSANT AVE.
ST. LOUIS, MO 63136**DATE:** 6/10/2016**P.O. NO.:** DT79
Order/Line
NO.: 22206 MN 100**TO:****Model Number:** DT79
Catalog Number: HO100V2SLG
VHS Weather Protected
CONF,MOTOR,VHS WPI**REVISIONS:**
(NONE)**ALL DOCUMENTS HEREIN ARE CONSIDERED CERTIFIED BY NIDEC MOTOR CORPORATION.****THANK YOU FOR YOUR ORDER AND THE OPPORTUNITY TO SERVE YOU.****Accessories:**Counter CW Rotation FODE
Shaft Ground Ring
Insul. Bearing - Upper Bracket
115 Volt Space Heaters
Special Balance
Thermostats - Normally Closed
. Standard Leadtime: 8-9 WEEKS
Est. Weight (lbs ea): 1110 ~ F.O.B.: Monterrey, Mexico**USE THE DATA PROVIDED BELOW TO SELECT THE APPROPRIATE DIMENSION PRINT**

Horsepower	100
Pole(s)	04
Voltage(s)	460
Frame Size	404TP
Outlet Box AF	3.38
Outlet Box AA	3.00

Nidec trademarks followed by the ® symbol are registered with the U.S. Patent and Trademark Office.

MOTOR PERFORMANCE

MODEL NO.	CATALOG NO.	PHASE	TYPE	FRAME
DT79	HO100V2SLG	3	RUSI	404TP

ORDER NO.	22206	LINE NO.	

MPI:	141574
HP:	100
POLES:	4
VOLTS:	460
HZ:	60
SERVICE FACTOR:	1.15
EFFICIENCY (%):	
S.F.	94.8
FULL	95.4
3/4	95.5
1/2	95.1
1/4	92.4
POWER FACTOR (%):	
S.F.	86.4
FULL	86.3
3/4	84.5
1/2	78.5
1/4	59.7
NO LOAD	5.1
LOCKED ROTOR	32.9
AMPS:	
S.F.	131
FULL	114
3/4	87
1/2	63
1/4	42
NO LOAD	32.8
LOCKED ROTOR	737.5
NEMA CODE LETTER	G
NEMA DESIGN LETTER	B
FULL LOAD RPM	1785
NEMA NOMINAL / EFFICIENCY (%)	95.4
GUARANTEED EFFICIENCY (%)	94.5
MAX KVAR	22.2
AMBIENT (°C)	40
ALTITUDE (FASL)	3300
SAFE STALL TIME-HOT (SEC)	25
SOUND PRESSURE (DBA @ 1M)	70
TORQUES:	
BREAKDOWN{% F.L.}	230
LOCKED ROTOR{% F.L.}	186
FULL LOAD{LB-FT}	294.3

NEMA Nominal and Guaranteed Efficiencies are up to 3,300 feet above sea level and 25 ° C ambient

The Above Data Is Typical, Sinewave Power Unless Noted Otherwise

NIDEC MOTOR CORPORATION
ST. LOUIS, MO



Nidec trademarks followed by the ® symbol are registered with the U.S. Patent and Trademark Office.



165975

Motor Wiring Diagram

Single Voltage, Wye or Delta Connection Part Winding Start (PWS)
Or
Full Winding – Across the Line Start

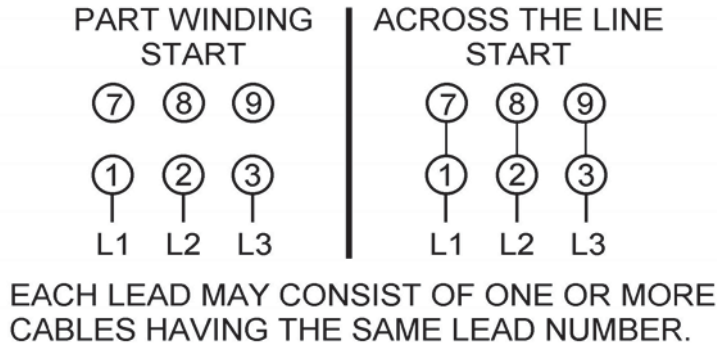

Per NEMA MG1 1998-1.75, "A Part-winding Start motor is one which certain specially designed circuits of each phase of the primary winding are initially connected to the supply line. The remaining circuit or circuits of each phase are connected to the supply in parallel with initially connected circuits, at a predetermined point in the starting operation." This is intended to limit the inrush current required to start the motor. NEMA MG1 1998-14.38 states that the motor may not accelerate to full speed in part-winding and may be noisier than when on full winding.

Motors designed by US Motors for Part-winding Start also be used for across the line starting using only the full winding connection. Damage will occur if the motor is operated with load for more than 2 seconds on Part-winding without transition to full winding.

To reverse direction of rotation, interchange leads L1 & L2.

Each lead may have one or more cables comprising that lead. In such case, each cable will be marked with the appropriate lead number.



165975

SPECIAL INFORMATION REGARDING PART WINDING STARTING

This motor is not designed to fully accelerate when started with the part winding start connection shown on the motor connection diagram. In order to avoid damaging the motor when it is started with the part winding start connection, set timers so that the motor starter switches the motor connection from start to run within two seconds from the time that the motor is initially energized. The motor is not expected to fully accelerate before the motor connection is switched to run, but the momentary operation on the start connection should allow time for automatic voltage regulators on the power system to compensate for voltage dip resulting from the high current draw of the motor during acceleration. Thus, voltage dip in the power system will be minimized through proper use of the part winding start connection. Once the motor has been switched over to the run connection, it will finish accelerating up to full speed.

During the time that the motor is operated on the part winding start connection, it is expected that the motor may be noisier than when operated on the run connection and it is also expected that the line amp unbalance between phases may be approximately 100% to 150%. This is due to the adverse effect of harmonics that result from the unbalanced magnetic circuit on the part winding start connection.

For further information regarding characteristics of polyphase induction motors when operated on a part winding start connection, refer to NEMA Publication MG 1-1998 Part 14.38.

THERMOSTATS

1. MOTOR IS EQUIPPED WITH QTY-3 (1 PER PHASE) NORMALLY CLOSED THERMOSTATS. THERMOSTATS ARE SET TO OPEN AT HIGH TEMPERATURE.
2. CONTACT RATINGS FOR THERMOSTATS: 120-600 VAC, 720 VA

N. C. THERMOSTATS

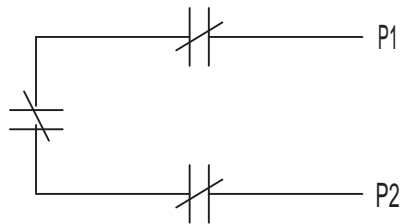

NOTE: THERMOSTATS LEADS MAY BE LOCATED IN EITHER THE MAIN OUTLET BOX OR IF SO EQUIPPED, AN AUXILIARY BOX.

ACCESSORY LISTING
QTY-3 N.C. THERMOSTATS

REVISION DESCRIPTION FOR: MISC	SCALE	UNITS	TITLE		NIDEC MOTOR CORPORATION
STL0211 - UPDATED FORMAT .	NONE	IN	CUSTOMER CONNECTION DIAGRAM		
	TOLERANCES ON DIMENSIONS (UNLESS OTHERWISE SPECIFIED)		ISSUED BY	APPROVED BY	REVISION DATE
MATERIAL:	<u>INCHES</u>	<u>mm</u>	R. KING	C. CADE	24-FEB-11
---	ANGLES X°= ±1°		CODE	DWG NO.	REV
MUST BE COMPLIANT TO RoHS DIRECTIVE EU 2002/95/IEC AND REGULATION EC 1907/2006 (REACH) AS AMENDED				0834066	G
					SHEET NUMBER
					1 OF 1
					DWG SIZE
					A

TYPICAL REED CRITICAL FREQUENCY DATA

Note: Motor RCF Test Data can be provided at time of motor shipment through special test.
Please contact your Nidec Motor Corporation representative for more information.

MODEL NO: DT79
CATALOG NO: HO100V2SLG

Frame: 404TP Type: RUSI

REED CRITICAL FREQUENCY:	43	HZ
CENTER OF GRAVITY:	18	IN
DEFLECTION @ CENTER OF GRAVITY:	0.0053	IN
UNIT WEIGHT:	1100	LBS
BASE DIAMETER:	ALL	IN
TOLERANCE ON RCF VALUE:	20%	
DATE:	6/10/2016	



Copyright © 2010 Nidec Motor Corporation. All rights reserved.

RENEWAL PARTS

FRAMES 324 THRU 445 - OPEN DRIPPROOF MOTORS
 TYPES: RU, RUE, RUI, RUS, RUSI, RV, RV4, RVE, RVE4, RVI, RVI4, RVS, RVS4

HIGH THRUST - WEATHER PROTECTED TYPE 1 - P BASE
 HOLLOSHAFT & SOLIDSHAFT MOTORS

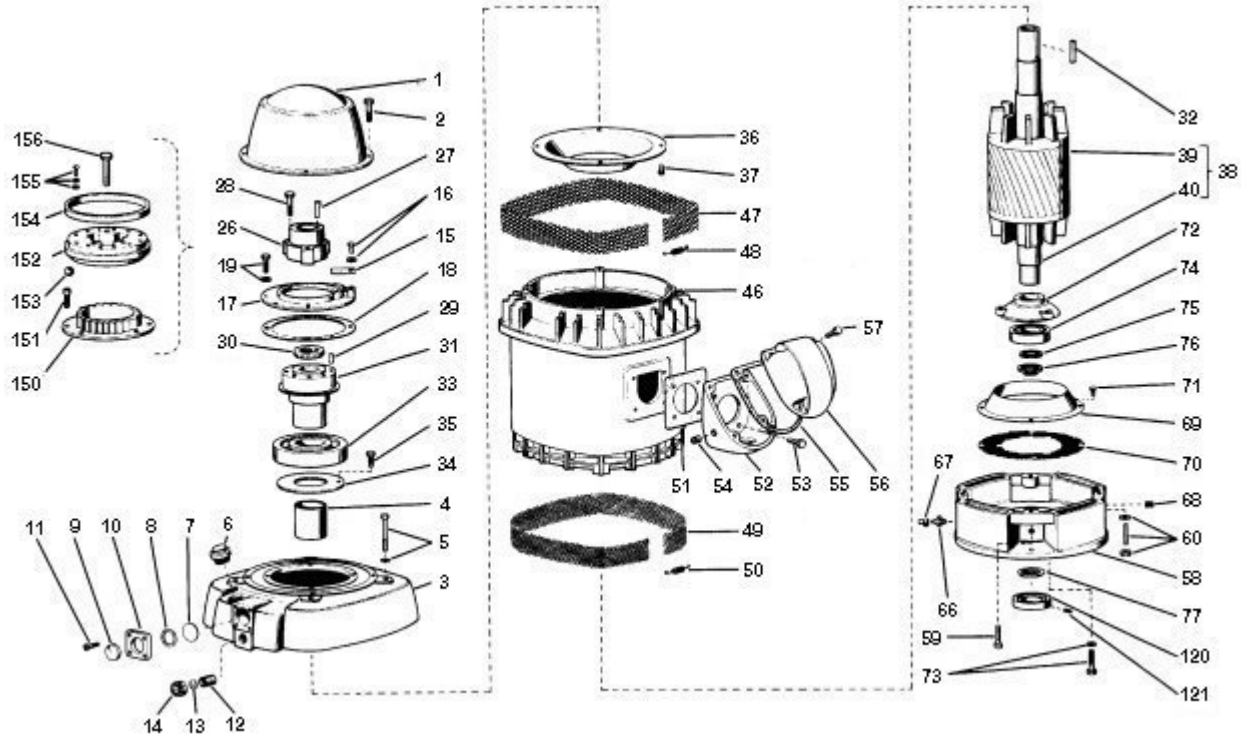

ITEM NO.	QTY	NAME OF PART
1	1	Canopy Cap
2	3	Hex Head Cap Screws (Canopy Cap)
3	1	Upper Bracket Assembly
4	1	Oil Retaining Tube
5	4	Hex Head Cap Screw & Lockwasher (Bracket to Stator)
6	1	Special Plug
7	1	Reflector Disc
8	2	Gasket - Sight Gauge
9	1	Sight Gauge Window
10	1	Sight Gauge Housing
11	4	Oval Head Screw (Sight Gauge)
12	1	Nipple Fitting (Oil Drain)
13	1	Gasket or "O" Ring

ITEM NO.	QTY	NAME OF PART
14	1	Drain Cap
15	1	Locking Arm
16	1	Hex Head Cap Screw & Lockwasher
17	1	Dust Ring
18	1	Gasket (Dust Ring)
19	3	Hex Head Cap Screw & Lockwasher
20-25	-	NOT USED THIS ASSEMBLY
26	1	Coupling (RU & RUE only)
27	1	Gib Key
28	3	Hex Head Cap Screw & Lockwasher (Bearing Mounting)
29	3	Spring Pin
30	1	Locknut / Lockwasher

WARNING:
 Any disassembly or repair work on explosionproof motors will void the Underwriters Laboratories, Inc. label unless done by the manufacturer, or a facility approved by the Underwriters Laboratories, Inc. Refer to your nearest sales office for assistance.

BEARINGS:
 Refer to motor nameplate for the bearing numbers.

PRICES:
 Parts stocking distributors: refer to renewal parts numerical index. All Others: refer to your nearest parts distributor.

reference: Renewal Parts Section 700, Pages 149 & 150

RENEWAL PARTS

FRAMES 324 THRU 445 - OPEN DRIPPROOF MOTORS
 TYPES: RU, RUE, RUI, RUS, RUSI, RV, RV4, RVE, RVE4, RVI, RVI4, RVS, RVS4

HIGH THRUST - WEATHER PROTECTED TYPE 1 - P BASE
 HOLLISHAFT & SOLIDSHAFT MOTORS

ITEM NO.	QTY	NAME OF PART
31	1	Bearing Mounting
32	1	Square Key
33	1	Ball Bearing (Upper) (Refer to Section 775)
34	1	Metering Plate (Used on 444 & 445 frames only)
35	1	Hex Head Cap Screw & Lockwasher (Used on 444 & 445 frames only)
36	1	Air Deflector (Upper)
37	7	Self-Tapping Screw (Air Deflector) Use Qty. 8 on 404 & 405 frame & Qty. 6 on 444 & 445 frame
38	1	Rotor Assembly (Includes items 39 & 40)
39	1	Rotor Core
40	1	Rotor Shaft
41-45	-	NOT USED THIS ASSEMBLY
46	1	Wound Stator Assembly
47	1	Grill (Upper Fume)
48	1	Expansion Spring
49	1	Grill (Lower Frame)
50	1	Expansion Spring
51	1	Gasket (Outlet Box Base)
52	1	Outlet Box Base
53	4	Hex Head Cap Screw
54	1	Hex Head Countersunk Pipe Plug
55	1	Gasket (Outlet Box Cover)
56	1	Outlet Box Cover
57	4	Hex Head Cap Screw (Outlet Box Cover)
58	1	Lower Bracket "P" Base
59	4	Hex Head Cap Screw (Not used on 404 & 405 frames)
60	4	Stud / Nut & Washer (Used on 404 & 405 frames only)

ITEM NO.	QTY	NAME OF PART
61-65	-	NOT USED THIS ASSEMBLY
66	1	Grease Fitting
67	1	Plastic Cap (Used on frames 404, 405, 444 & 445 only)
68	1	Pipe Plug
69	1	Lower Air Deflector
70	1	Lower Screen
71	4	Hex Head Cap Screw & Lockwasher (Qty. 8 on 404 & 405 frames, Qty. 6 on 444 & 445 frames)
72	1	Lower Bearing Cap
73	3	Hex Head Cap Screw / Lockwasher
74	1	Ball Bearing (Lower) (Refer to Section 775)
75	1	Bearing Spacer (Lower)
76	1	Snap Ring
77	1	Water Deflector
FOR UNITS WITH STABILIZER BUSHINGS, OMIT ITEM NO. 77 & ADD THE FOLLOWING:		
120	1	Stabilizer Bushing
121	2	Socket Set Screws
FOR UNITS WITH NON-REVERSE RATCHETS, OMIT ITEM NO.'s 15, 17 & 19 AND ADD THE FOLLOWING:		
150	1	Stationary Ratchet
151	3	Socket Head Cap Screws
152	1	Rotating Ratchet
153	12	Steel Balls
154	1	Ball Retaining Ring
155	6	Round Head Machine Screws, Lockwasher & Plain Washers
156	3	Hex Head Cap Screws

WARNING:
 Any disassembly or repair work on explosionproof motors will void the Underwriters Laboratories, Inc. label unless done by the manufacturer, or a facility approved by the Underwriters Laboratories, Inc. Refer to your nearest sales office for assistance.

BEARINGS:
 Refer to motor nameplate for the bearing numbers.

PRICES:
 Parts stocking distributors: refer to renewal parts numerical index. All Others: refer to your nearest parts distributor.

reference: Renewal Parts Section 700, Pages 149 & 150

Copyright © 2010 Nidec Motor Corporation. All rights reserved.

EFFECTIVE:
02-MAR-11

VERTICAL MOTORS

WEATHER PROTECTED TYPE I

PRINT:
09-2293

SUPERSEDES:
31-JUL-03

FRAME: 404, 405TP, TPA
TYPE: RU, RUE, RUI, **RUS**

SHEET:
1 OF 1

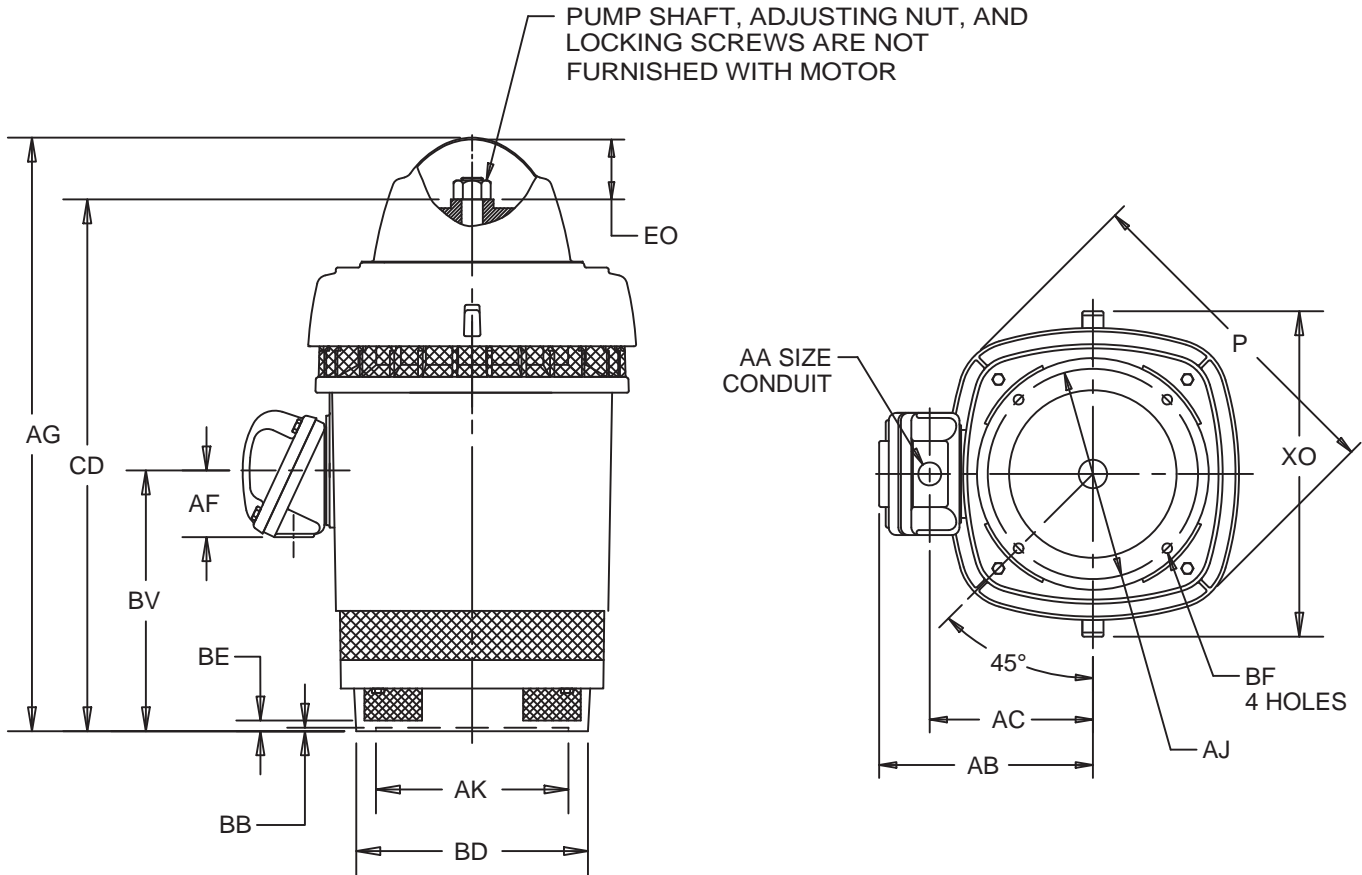

DIMENSIONS ARE IN INCHES AND MILLIMETERS

UNITS	P ²	AG	AJ	AK +.005	BB MIN	BE	BF	BV	CD	EO	XO
IN	23.75	42.69	14.750	13.500	.25	.75	.69	18.13	36.94	5.50	24.13
MM	603	1084	374.65	342.90	6	19	18	461	938	140	613

FRAME	CONDUIT BOX MATERIAL	UNITS	AA	AB	AC	AF
400	STEEL	IN	3.00	16.97	12.69	3.38
		MM		431	322	86
	CAST IRON	IN	3 NPT	17.75	13.38	4.63
		MM		451	340	118

FRAME	UNITS	BD MAX
404, 405TP	IN	16.50
	MM	419
404, 405TPA	IN	20.00
	MM	508

- 1: ALL ROUGH DIMENSIONS MAY VARY BY .25" DUE TO CASTING AND/OR FABRICATION VARIATIONS.
- 2: LARGEST MOTOR WIDTH.
- 3: TOLERANCES SHOWN ARE IN INCHES ONLY.
- 4: CONDUIT BOX OPENING MAY BE LOCATED IN STEPS OF 90° REGARDLESS OF LOCATION. STANDARD AS SHOWN WITH CONDUIT OPENING DOWN.

TOLERANCES	
FACE RUNOUT	.007 T.I.R.
PERMISSIBLE ECCENTRICITY OF MOUNTING RABBET	.007 T.I.R.

09-2293/B

Nidec Motor Corporation
St. Louis, Missouri

INFORMATION DISCLOSED ON THIS DOCUMENT IS CONSIDERED PROPRIETARY AND SHALL NOT BE REPRODUCED OR DISCLOSED WITHOUT WRITTEN CONSENT OF NIDEC MOTOR CORPORATION



ISSUED BY
R. KING
APPROVED BY
M. TREJO

IHP_DP_NMCA (MAR-2011) SOLIDEDGE

Vertical HOLLOSHAFT Coupling Dimensions

Standard Coupling Dimensions

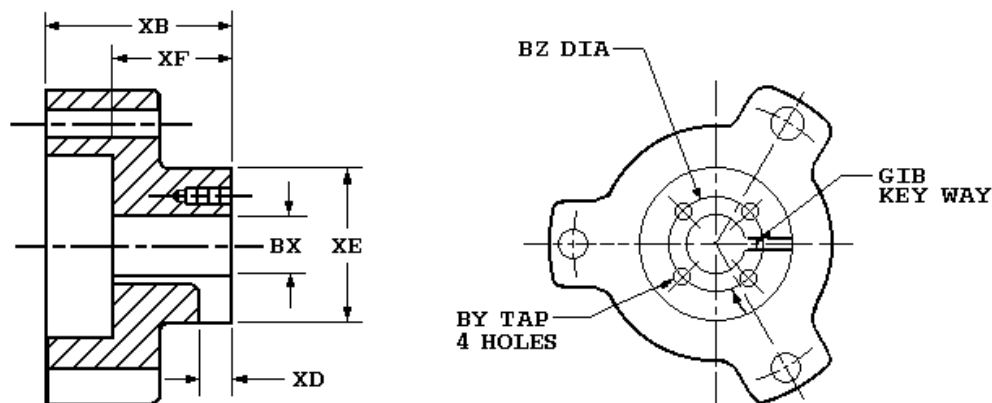

Coupling Part Number	133003
BX Nominal	1 1/2
Actual Bore	1.501
BY	1/4-20
BZ	2 1/8
XB	3 13/32
XD	17/32
XE	3 1/8
XF	2 13/32
SQ. KEY	3/8

Notes:

1. All Rough casting dimensions may vary by 0.25" due to casting variations.
2. All tapped holes are Unified National Course, Right Hand thread.
3. Coupling bore dimension "BX" is machined with a tolerance of - .000", +.001" up to 1.50" bore inclusive. Larger bores: -.000", +.002".



Copyright © 2010 Nidec Motor Corporation. All rights reserved.

General Information for Integral Horsepower (IHP) Motors on Variable Frequency Drives (VFDs)

Variable Frequency Drives (VFD)

A VFD is a type of controller used to vary the speed of an electric motor. The VFD takes a fixed AC voltage and frequency and allows it to be adjusted in order to get different speeds from the motor. Motor speed can be varied by changing the frequency of the input power waveform. The equation below shows how the frequency affects the speed of a three phase induction motor.

$$\text{Speed} = \frac{120 \times \text{Fundamental Input Frequency}}{\text{Number of Motor Poles}}$$

How does a VFD work?

A VFD takes the fixed frequency and voltage sine wave from the power grid or power station and puts it through a few steps in order to allow the VFD user to vary the frequency and in turn control the motor speed. First it rectifies the AC power into DC Power. Because of this step, a term commonly used instead of VFD is inverter. This only describes one step of what the VFD does to the power waveform. Once rectified into a DC voltage the drive sends the power through a set of transistors or switches. These switches can take the DC waveform and by opening and closing at certain speeds and durations can create an output waveform that mimics the sine wave that is required to drive a three phase electric motor. The output wave form is known as a Pulse Width Modulation (PWM) waveform because the waveform is created by multiple pulses of the switches at short intervals.

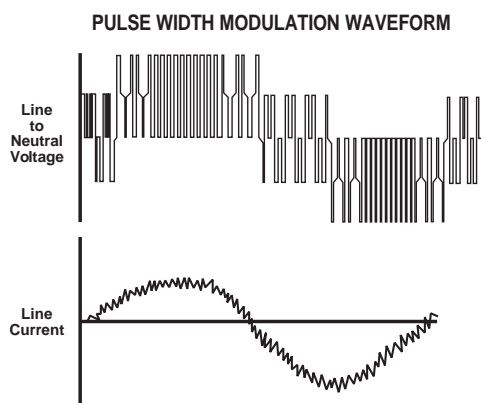

Figure 1 PWM Waveform

What variables should be considered when deciding whether to power a motor with a VFD?

VFD compatibility with motors is complex. As a result, many variables must be considered when determining the suitability of a particular motor for use with a VFD. These variables include:

- Torque requirements (Constant or Variable)
- Speed Range
- Line / System Voltage
- Cable length between the VFD and the motor
- Drive switching (carrier) frequency
- Motor construction

- VFD dv/dt
- High temperatures or high humidity
- Grounding system

Wider speed ranges, higher voltages, higher switching frequencies, insufficient grounding and increased cable lengths all add to the severity of the application and, therefore, the potential for premature motor failure.

How does a VFD affect the motor?

There are many things to consider when a motor is powered using a VFD or PWM power. When a motor is powered by a PWM waveform the motor windings very often see a large differential voltage, either from phase to phase or turn to turn. When the voltage differential becomes large enough it creates a reaction at the molecular level that converts available oxygen into O₃. This phenomenon is called partial discharge or corona. This reaction creates energy in the form of light and heat. This energy has a corrosive effect on the varnish used to protect the motor windings. PWM waveforms can also magnify shaft voltages which lead to arcing across the bearing and causing premature bearing failure. Corrective action must be taken to mitigate these issues that arise when using an electric motor with a VFD.

How do I protect the motor?

Nidec Motor Corporation (NMC) has developed specific motor designs to decrease the harmful affects that a VFD can have on a motor. NMC's INVERTER GRADE[®] insulation system is the first line of defense against corona and phase to phase faults that can be common when a motor is powered using a PWM waveform. The INVERTER GRADE[®] insulation system is standard on all of NMC's Inverter Duty products. Along with the INVERTER GRADE[®] insulation, thermostats are installed as a minimum protection against over heating the motor. Special consideration must also be given to bearings in motors powered by VFD's. In order to create a low resistance path to ground for built up shaft voltages a shaft grounding device can be used. On larger horsepower motors an insulated bearing system should be used in conjunction with the shaft grounding device when installed, to force the stray shaft voltages to ground. The bearing failures are more prominent on motors with thrust handling bearings. NMC has created an Inverter Duty vertical motor line that not only uses the INVERTER GRADE[®] insulation system, but that also comes standard with a shaft grounding device. On motors that are 100 HP and greater the thrust bearing is also insulated for additional protection.

What does "Inverter Duty" mean?

An Inverter Duty motor should describe a motor that helps mitigate potential failure modes of a motor that is powered by a VFD. Inverter duty motor windings should be able to withstand the voltage spikes per NEMA MG1 Part 31.4.4.2 and protect against overheating when the motor is run at slow speeds. On thrust handling bearings it is apparent that the bearings require additional protection. Inverter Duty vertical motors should have a shaft grounding device to protect the motor bearings from fluting due to voltage discharge through the bearing. On larger motors (100HP and larger) the shaft should also be electrically isolated from the frame in order to aid the shaft grounding ring in discharging the shaft voltages to ground.

*This information applies only to Integral Horsepower (IHP) motors as defined on the Agency Approval page, under UL[®] & CSA[®] listings where indicated.

† All marks shown within this document are properties of their respective owners.



Motor / Inverter Compatibility

Thermal Overloads and Single Phase Motors

Motors with thermal overloads installed may not operate properly on a VFD. The current carrying thermal overload is designed for sine wave power. Operation on a VFD may cause nuisance tripping or potentially not protect the motor as would be expected on line power. Thermostats or thermistors installed in the motor and connected properly to the VFD may provide suitable thermal overload protection when operating on a VFD. (consult codes for installation requirements)

Single phase motors and other fractional horsepower ratings are not designed to be operated on a VFD. Within Nidec Motor Corporation standard products, all motors NEMA[®] 48 frame (5.5" diameter) and smaller are not suitable for VFD applications. Three phase 56 and 143/145 frame applications should be noted on the catalog price page; or if in doubt ask an Nidec Motor Corporation technical representative for recommendations on compatibility with a VFD.

Slow Speed Motors

Motors with a base design of slower than six poles require special consideration regarding VFD sizing and minimizing harmonic distortion created at the motor terminals due to cable installation characteristics. Additional external PWM waveform filters and shielded motor cables designed for PWM power may be required to provide acceptable motor life. Harmonic distortion on the output waveform should be kept to a minimum level (less than 10%) mismatch impedance.

690V Applications

Motors that are rated for 690VAC and that will be powered by 690VAC PWM VFDs require the use of an external filter to limit peak voltage spikes and the use of an INVERTER GRADE[®] motor. Where available, an alternative to using an output filter is to upgrade to a 2300V insulation system.

Low Voltage TITAN[®] Motors

When using 449 frame and larger motors on PWM type VFDs consider the use of an external filter and shielded motor cables designed for PWM power to minimize harmonic distortion and peak voltages at the motor terminals. Harmonic distortion on the output waveform should be kept to a minimum level (less than 10%).

Bearing Currents Related to PWM Waveforms

Due to the uniqueness of this condition occurring in the field, protection of the motor bearings from shaft currents caused by common mode voltages is not a standard feature on sine wave or Inverter Duty motor products, unless explicitly noted. Some installations may be prone to a voltage discharge condition through the motor bearings called Electrical Discharge Machining (EDM) or fluting.

EDM damage is related to characteristics of the PWM waveform, and the VFD programming, and installation factors.

Bearing EDM as a result of VFD waveform characteristics may be prevented by the installation of a shaft grounding device such as a brush or ring and/or correction of the installation characteristics causing the shaft voltage condition. Insulated bearing(s) may be required. VFD filters may be used if bearing fluting is to be mitigated.

Bearing Protection on Inverter Duty Vertical Motors

All U.S. MOTORS[®] brand "Inverter Duty" vertical products have a shaft grounding system that allows damaging shaft currents a low resistance path to ground. **Bearings on vertical motors fed by VFD power without this bearing protection are not covered under any warranty.** All other bearing failure is covered per NMC's standard warranty. An electric motor repair shop approved to service U.S. MOTORS[®] brand motors must verify that the cause of the bearing failure was not due to EDM damage.

Multiple Motors on a Single VFD

Special considerations are required when multiple motors are powered from a single VFD unit. Most VFD manufacturers can provide guidelines for proper motor thermal considerations and starting/stopping of motors. Cable runs from the VFD and each motor can create conditions that will cause extra stress on the motor winding. Filters may be required at the motor to provide maximum motor life.

Grounding and Cable Installation Guidelines

Proper output winding and grounding practices can be instrumental in minimizing motor related failures caused by PWM waveform characteristics and installation factors. VFD manufacturers typically provide detailed guidelines on the proper grounding of the motor to the VFD and output cable routing. Cabling manufacturers provide recommended cable types for PWM installations and critical information concerning output wiring impedance and capacitance to ground.

Vertical Motors on VFDs

Vertical motors operated on VFD power present unique conditions that may require consideration by the user or installation engineer:

- Locked rotor and drive tripping caused by non-reversing-ratchet operation at low motor speeds. It is not recommended to operate motors at less than 1/4 of synchronous speed. If slow speeds are required contact NMC engineering.
- Unexpected / unacceptable system vibration and or noise levels caused by the torque pulsation characteristics of the PWM waveform, a system critical frequency falling inside the variable speed range of the process or the added harmonic content of the PWM waveform exciting a system component
- Application related problems related to the controlled acceleration/ deceleration and torque of the motor on VFD power and the building of system pressure/ load.
- The impact the reduction of pump speed has on the down thrust reflected to the pump motor and any minimum thrust requirements of the motor bearings
- Water hammer during shutdown damaging the non-reversing ratchet

Humidity and Non-operational Conditions

The possible build-up of condensation inside the motor due to storage in an uncontrolled environment or non-operational periods in an installation, can lead to an increased rate of premature winding or bearing failures when combined with the stresses associated with PWM waveform characteristics. Moisture and condensation in and on the motor winding over time can provide tracking paths to ground, lower the resistance of the motor winding to ground, and lower the Corona Inception Voltage (CIV) level of the winding.

Proper storage and maintenance guidelines are important to minimize the potential of premature failures. Space heaters or trickle voltage heating methods are the common methods for drying out a winding that has low resistance readings. **Damage caused by these factors are not covered by the limited warranty provided for the motor unless appropriate heating methods are properly utilized during non-operational periods and prior to motor start-up.**

NEMA[®] Application Guide for AC Adjustable Speed Drive Systems: <http://www.nema.org/stds/acadjustable.cfm#download>

* This information applies only to Integral Horsepower (IHP) motors as defined on the Agency Approval page, under UL[™] & CSA[™] listings where indicated.

† All marks shown within this document are properties of their respective owners.

Warranty Guidelines for Integral Horsepower (IHP)* Motors on Variable Frequency Drives

Warranty Guidelines

The information in the following section refers to the motor and drive application guidelines and limitations for warranty.

Hazardous Location Motors

Use of a variable frequency drive with the motors in this catalog, intended for use in hazardous locations, is only approved for Division 1, Class I, Group D hazardous location motors with a T2B temperature code, with a limitation of 2:1 constant torque or 10:1 variable torque output. **No other stock hazardous location motors are inherently suitable for operation with a variable frequency drive.** If other requirements are needed, including non-listed Division 2, please contact your Nidec Motor Corporation territory manager to conduct an engineering inquiry.

575 Volt Motors

575 volt motors can be applied on Inverters when output filters are used. Contact the drive manufacturer for filter selection and installation requirements.

Applying INVERTER GRADE® Insulated Motors on Variable Frequency Drives (2, 4, 6 pole)

The products within this catalog labeled “Inverter Duty” or “Vector Duty” are considered INVERTER GRADE® insulated motors. INVERTER GRADE® motors exceed the NEMA® MG-1 Part 31 standard. Nidec Motor Corporation provides a three-year limited warranty on all NEMA® frame INVERTER GRADE® insulated motors and allows long cable runs between the motor and the VFD (limited to 400 feet without output filters). Cable distance can be further limited by hot and humid environments and VFD manufacturers cable limits. These motors may be appropriate for certain severe inverter applications or when the factors relating to the end use application are undefined (such as spares).

Nidec Motor Corporation’s U.S. Motors® brand is available in the following INVERTER GRADE® insulated motors:

- Inverter Duty NEMA® frame motors good for 10:1 Variable Torque & 5:1 Constant Torque, including Vertical Type RUSI
- Inverter Duty motors rated for 10:1 Constant Torque
- ACCU-Torq® and Vector Duty Motors with full torque to 0 Speed
- 841 Plus® NEMA® Frame Motors

Applying Premium Efficient motors (that do not have INVERTER GRADE® insulation) on Variable Frequency Drives (2, 4, 6 pole)

Premium efficient motors without INVERTER GRADE insulation meet minimum NEMA® MG-1, Section IV, Part 31.4.4.2. These motors can be used with Variable Frequency Drives (with a reduced warranty period) under the following parameters:

- On NEMA® frame motors, 10:1 speed rating on variable torque loads & 4:1 speed range on constant torque loads.
- On TITAN® frame motors, 10:1 speed rating on variable torque loads.
- On TITAN® frame motors, inquiry required for suitability on constant torque loads.

Cable distances are for reference only and can be further limited by hot and humid environments (refer to Table 1). Refer to specific VFD manufacturers cable limits. Refer to the Motor/ Inverter Compatibility page for special consideration of vertical motor bearings.

Table 1 - Cable Distances			
Maximum Cable Distance VFD to Motor			
Switching Frequency	460 Volt	230 Volt	380 Volt
3 Khz	127 ft	400 ft	218 ft
6 Khz	90 ft	307 ft	154 ft
9 Khz	73 ft	251 ft	126 ft
12 Khz	64 ft	217 ft	109 ft
15 Khz	57 ft	194 ft	98 ft
20 Khz	49 ft	168 ft	85 ft

Warranty Period Clarifications and Exceptions

Standard Energy Efficient Exclusion

Applying Standard & Energy Efficient Motors on Variable Frequency Drives is not recommended. VFD related failures on standard and energy efficient motors will not be covered under warranty.

Vertical Motor Windings

Premium efficient vertical motors without INVERTER GRADE® insulation that are installed using the criteria described in this document and applied in the correct applications shall have a warranty while powered by a VFD for 12 months from date of installation or 18 months from date of manufacturing whichever comes first. See limited warranty page for horizontal motor warranty periods.

Bearing Exclusion for Thrust Handling Bearings

Bearings used in premium efficient vertical motors, and all thrust handling bearings, that are powered by VFDs without shaft grounding devices or insulated bearings (when required) will **not** be covered under any warranty for damages caused from being powered by a VFD. All other bearing failure is covered per NMC’s standard warranty. An electric motor repair shop approved to service U.S. MOTORS® brand motors must verify that the cause of the bearing failure was not due to Electrical Discharge Machining.

Medium Voltage and Slow Speed Considerations

Motors that are rated above 700 VAC or that are eight pole and slower require special consideration and installation and are **not** covered under the warranty guidelines in this document. Motors that are rated above 700VAC have special cable length and voltage differential issues that are specific to the VFD type and manufacture. The motor construction and cost may vary dramatically depending on the VFD topology and construction. Contact your NMC representative with VFD manufacturer name and model type for application and motor construction considerations. Motors that are designed eight pole and slower also require special installation and filters per the drive manufacturer.

* This information applies only to Integral Horsepower (IHP) motors as defined on the Agency Approval page, under UL™ & CSA™ listings where indicated.

† All marks shown within this document are properties of their respective owners.

