

HUBER

TECHNOLOGY

WASTE WATER Solutions

Huber STRAINPRESS® Pressurized Sludge Screen

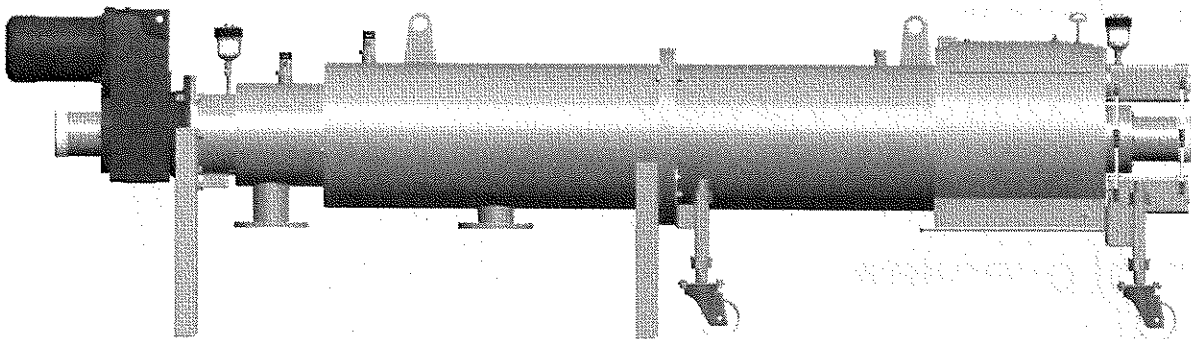

Customer Training Manual

Strainpress Training Manual

Table of contents :

- Overview of Principle components
- Principle of operation
- Safety features
- Screen controls overview
- Control Philosophy
- Internal overview
- Maintenance
- External overviews
- Troubleshooting
- Summary

Note :

This manual is for training purposes only – reference should be made to the SP4 O&M manual prior to undertaking any work on the unit.
Huber SP4 Customer
Training Manual

Principle Components

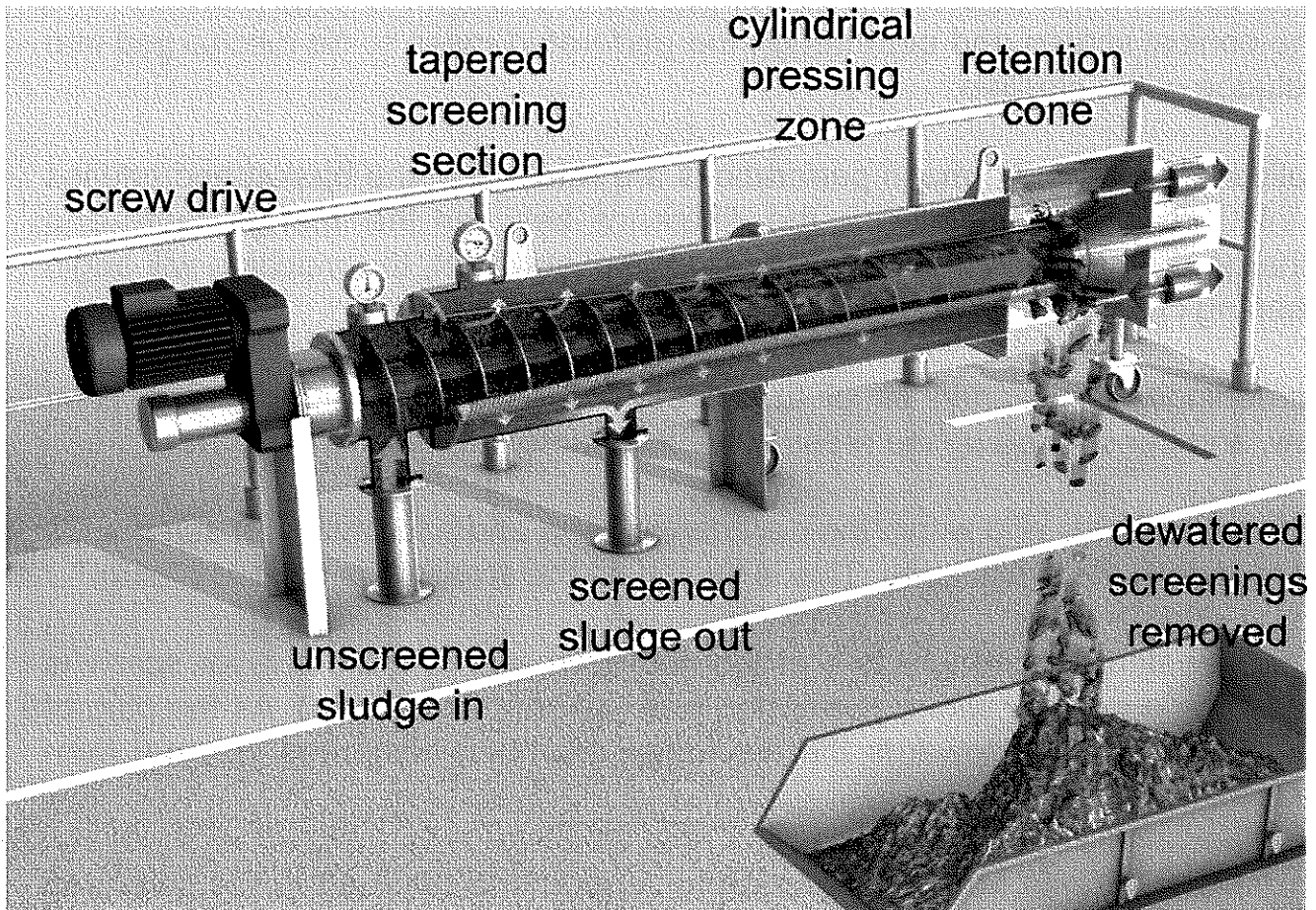

Principle of Operation

- Unscreened sludge enters the screen via the sludge inlet pipeline.
- The screenings zone comprises a conical section perforated mesh basket (typically $\varnothing 5\text{mm}$ perforations, but other sizes are available) and the matching conical screen zone screw. The sludge passes in through the large diameter end of the conical screen and out through the perforated mesh to be discharged into the sludge outlet pipeline.
- Solids larger than the mesh perforations are retained in the basket and causes the inlet pressure to rise. Once the difference between the inlet pressure and discharge pressure reaches the start differential set point, the machine will begin a cleaning cycle.
- Screenings are cleaned off of the screen zone screen by the screen zone screw, and transported by the press zone screw into the dewatering zone.
- The screw flights end within the dewatering zone and a formation of screenings start to form in the press zone. This is known as the screenings or solids "plug."
- The dewatering zone which is at the non-drive end of the conveyor screw is encased by a cylinder with a perforated wall ($\varnothing 2\text{mm}$ perforations). As the plug of screenings is pushed towards the discharge chamber, effluent is pressed from the screenings.
- The effluent drains from the dewatering zone and is returned to the screened sludge flow.
- The discharge of screenings from the discharge chamber is controlled by the combined action of the discharge nozzle and the screenings retention cone.

Principle of Operation (continued)

- Force is applied to the screenings retention cone via two pneumatic actuators. This force provides a retention pressure against the screenings and enhances the screenings dewatering process. The retention pressure is regulated by an electro-pneumatic regulator linked to a motor power monitor (MPM).
- This system allows the force of the screenings retention cone to be optimized while ensuring that neither the motor is overloaded nor the screen is overstressed.
- The system must maintain a healthy air pressure at all times, and cannot be operated without it.
- The maximum allowable differential across the screens is 17psi, while the maximum allowable overall internal pressure of the machine is 43psi.

Safety features

SAFETY FEATURES

The electrical control panel incorporates the following safety features:

Emergency Stop - The emergency stop pushbutton is of the stay-put/twist release type. When the emergency stop is pressed the screen stops or is prevented from starting. Before the screen will restart, the emergency stop pushbutton must be released and the reset pushbutton pressed.

Screen Controls Overview.

- Two control panels are required for the operation of the screen. One of the control panels house the main disconnect, electrical controls and indicators, the other houses the electro-pneumatic controls, indicators and a compressed air system which provides the pneumatic function.
- The electrical control panel is either mounted adjacent to the screen or may be mounted remotely with the addition of an emergency stop adjacent to the screen. It is recommended that the pneumatic control panel should be mounted within 30 feet of the screen's pneumatic actuators.
- The standard control panel enclosures are of stainless steel and offer IP65 protection.(NEMA4x).
- The compressed air system comprises a piston compressor an air receiver or regulator complete with pressure switch, an automatic anti-condensate drain valve , an electro-pneumatic regulator, manual pressure regulator, and a 3 way pneumatic solenoid valve.

Control Philosophy

HAND MODE - In *hand* mode, the screen will only start and stop in response to the Hand-Off-Auto selector switch on the front of the control panel. *Hand* mode is provided for maintenance purposes only, and the sludge feed pump remains inhibited when the screen is operating in this mode.

AUTO MODE - In *Auto* mode the machine will start immediately when the start differential pressure or start pressure set point is reached. The screen continues to operate until the differential and/or start pressure drops below the start level, after which the screen continues to operate until the time in the off-delay timer has expired. The screen will re-start as soon as the start differential pressure or start pressure again exceeds their respective set point.

In *Auto* mode the operation of the sludge feed pump or feed valve is interlocked with the *auto available* relay in the screen control panel. This serves to inhibit operation of the pump if the screen is not *available*.

Auto Available is defined as follows:

- no trip conditions
- selector switch in *Auto*
- power supply available
- no moisture detected
- emergency stop/interlock switches not operated
- the pneumatic air supply is healthy (minimum 75psi). This is monitored by a pneumatic pressure switch.

Note: The screen will automatically try to re-start after failure of the air supply.

Control Philosophy (continued)

Motor Power Monitor

□ The motor power monitor is used to measure the load on the screen drive motor and control the air pressure that is applied to the screenings retention cone actuators. The device measures voltage, current, frequency and power factor and calculates real power consumption. The power consumption is shown on the power monitor's digital display and on the analogue power meters fitted to the electrical control panels Operator Interface Unit.

□ The power monitor's 4-20mA output is connected to the electro-pneumatic regulator in the pneumatic control panel, which automatically adjusts the air pressure. Motor power consumption is typically in the 20% range of full load power (flp) when the screen is running idle, rising up to 80% flp when screenings are discharged at 35-45% dry solid.

□ The Strainpress should be set to trip if the power consumption exceeds 80% (set point available in OUI).

□ The pneumatic actuators apply force to the screenings retention cone to ensure that the screen's dewatering performance is optimised. Maximum closing pressure is applied to the screenings retention cone when motor power is at and below the Strainpress minimum power set point. A balanced pressure (i.e. equalised pressure on both sides of the actuator) is applied when the motor power is at and above the Strainpress maximum power set point.

Control Philosophy (continued)

When the Strainpress begins to run, the power monitor will provide a 4-20mA signal proportional to motor load from 0-100% of motor nameplate power. This signal will be used by the electro-pneumatic regulator to adjust the amount of air pressure to the control side of the pneumatic cylinders. As motor power fluctuates between the minimum and maximum power set points, the air pressure will fluctuate between the minimum and maximum control power set points.

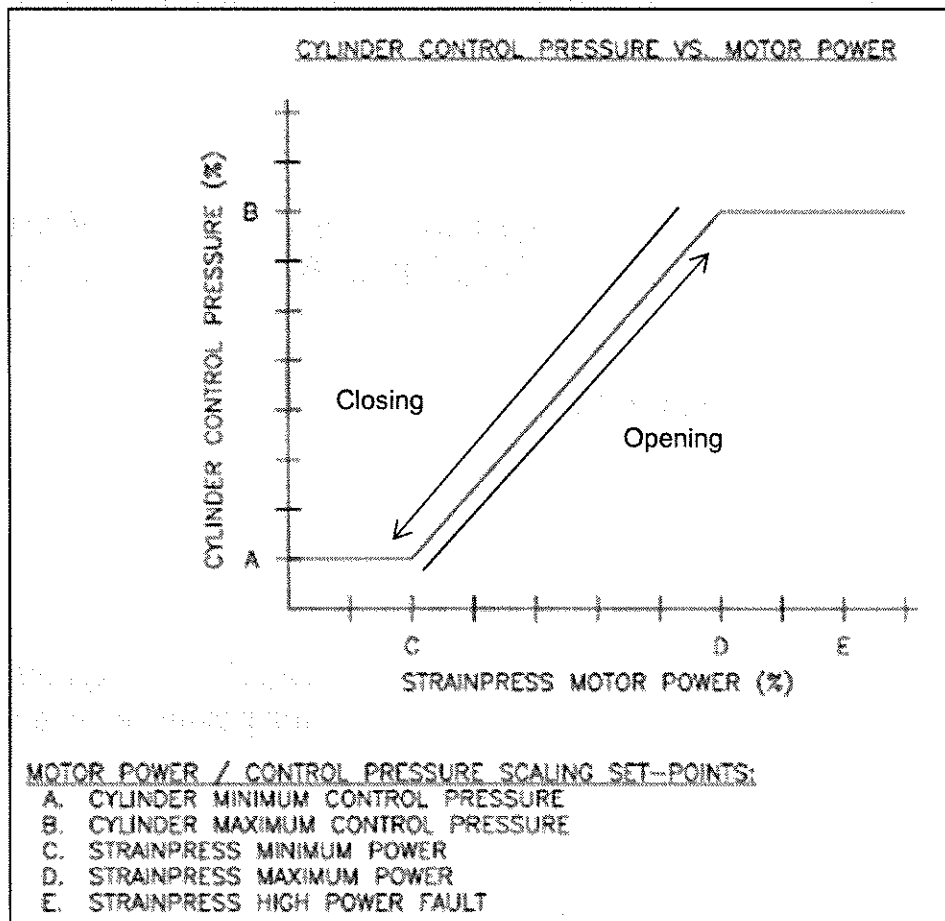

Strainpress Internal Overview

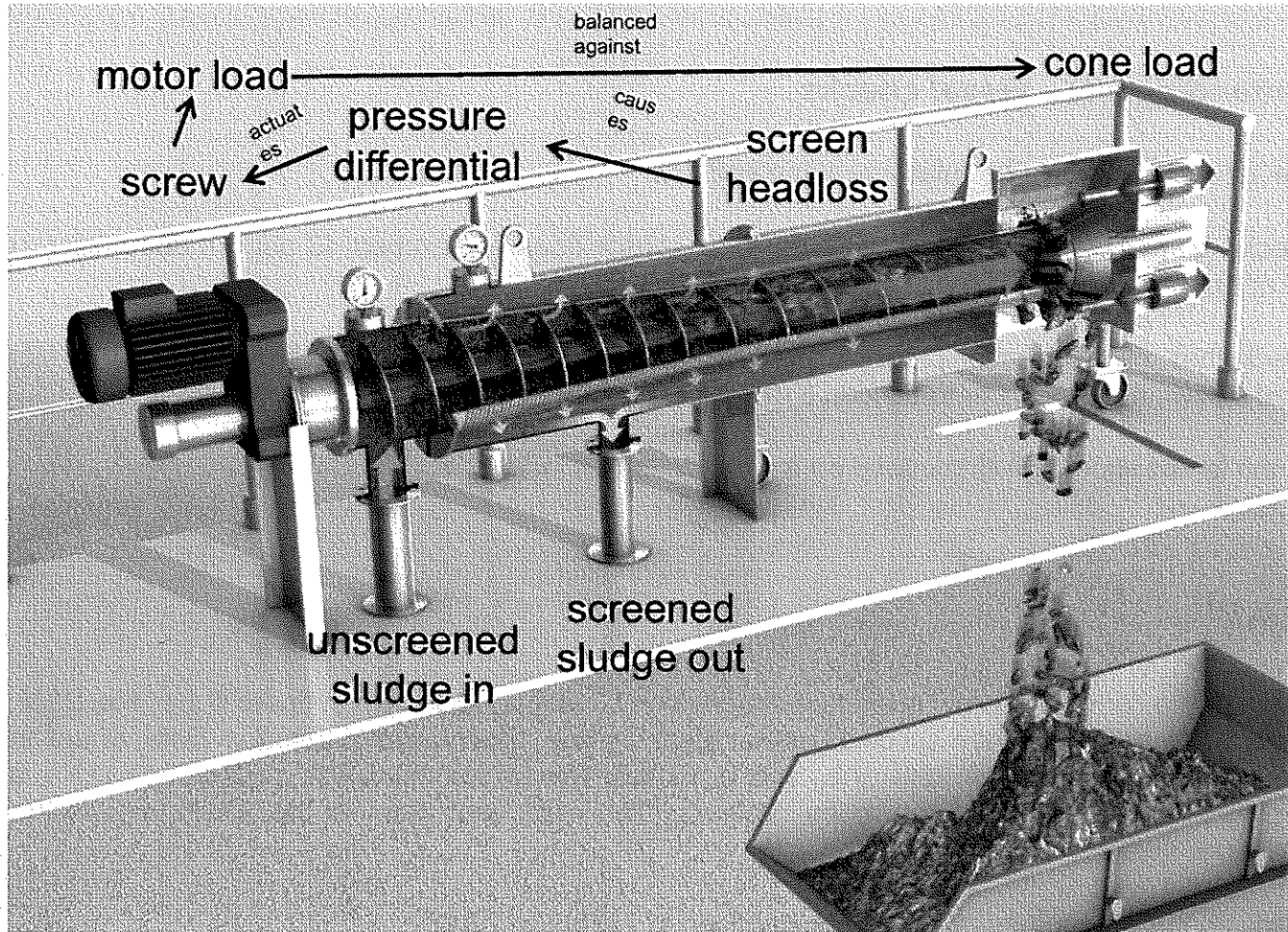

This view depicts how the sludge is screened and how the screenings are transported and discharged from the Strainpress

Maintenance

On attending site - Visual checks

- The screenings should be relatively clean and dry.
- Check that the pressure on the inlet pressure sensor does not exceed 43 psi. If it does refer to O&M or troubleshooting.
- Check that the differential pressure between the inlet and outlet pressure sensors does not exceed 17 psi. If it does refer to section 8 of the O&M.
- No trip lamps should be illuminated on the control panel fascia.

Monthly

- Measure the conveyor screw reference dimensions L_v and L_H as shown in figure 6.1 of the O&M. Record these and the other specified parameters on the *Strainpress Operation Data Sheet* in section 10 of the O&M. The sum of L_v and L_H should remain constant. If $L_H > 55\text{mm}$ (2.125"), a replacement conveyor screw should be ordered. (The main wear item in the Strainpress is the screen zone screw.)
- Lubricate the Strainpress at the points identified in 7.2 of the O&M.
- Check operation of the screenings retention cone is in a good working order. Clean and grease the section of the screw conveyor shaft over which the cone slides.
- Check the operation of the moisture sensor. Test by pressing a wet cloth against the sensor. The Strainpress and sludge feed pump and/or valve should shut off immediately.

Maintenance (continued)

Bi-annually (every 6 months)

Check the operation of the compressor safety valve & replace both auto greasers.

Yearly

- Repeat the *Commissioning Procedure* in section 6 of the O&M.
- Check for oil leaks from the geared motor.
- Change the compressor suction filter.
- Split the two halves of the Strainpress at the central flange. Clean and inspect the tapered and parallel screen sections.

2 years/10,000 hours screen operation

Change the lubricant in the geared motor. Remove the motor rotor bearings. Clean, inspect, re-lubricate and re-assemble.

Maintenance (continued)

As needed.

Adjust screen zone screw.

Screen Zone Screw Adjustment.

Periodically the screen zone screw needs adjusting to maintain the tight clearance against the screen zone screen as it wears. When symptoms arrive, operations should contact maintenance and have the screw adjusted to avoid operation problems.

Symptoms screw may need adjustment

- The screen dwells for shorter periods of time when flow rates or DS% has no increased.
- The machine runs continuously even though flow rates or DS% has not increased.
- When the machine is running the inlet pressure does not decrease.
- The motor power % falls below the point of last adjustment.

If any of the above symptoms are displayed either individually or simultaneously, it is likely the screen zone screw needs adjustment.

Maintenance (continued)

Adjusting the screw.

Take the following steps to adjust the screen zone screw:

1. Isolate the machine by closing inlet and discharge valves and turning the Hand-Off-Auto switch to the OFF position.
2. Allow pressure to dissipate from machine. (both sensors read <1psi.
3. Open the cone by setting the cone direction selector switch on the control panel from Forward to Reverse. (All screw adjustments must be made with the cone in the OPEN position.)
4. Place the machine in the HAND mode and allow it run for 1 minute while monitoring the motor power % on the Operator Interface.
5. Record this base power % (BS)
6. Remove the cover over the adjusting nuts.
7. Using the provided specialty tools break the lock nut from the adjusting nut being careful not to move the adjusting nut.
8. Turning the adjusting nut clockwise in small increments, then re-tighten the lock nut.
9. Place the machine back in HAND mode and allow it run for 1 minute while monitoring the motor power % on the Operator Interface.
10. Record this power % (A)
11. Continue this process in small increments until you increase the motor power % by 10 percentage points after 1 minute of runtime. ($BS + 10 = A$)
12. Replace the cover on the adjusting nuts.
13. Place the cone directional selector switch from the Reverse to the Forward position.
14. Place the Hand-Off-Auto switch to the AUTO position.
15. Open isolation valves and introduce flow to the machine.
16. Measure new L_H . (Screw must be replaced at 55mm to prevent damage.)

Strainpress External view

Inlet pressure sensor.
Start & High pressure detected by
this gauge

Discharge pressure sensor

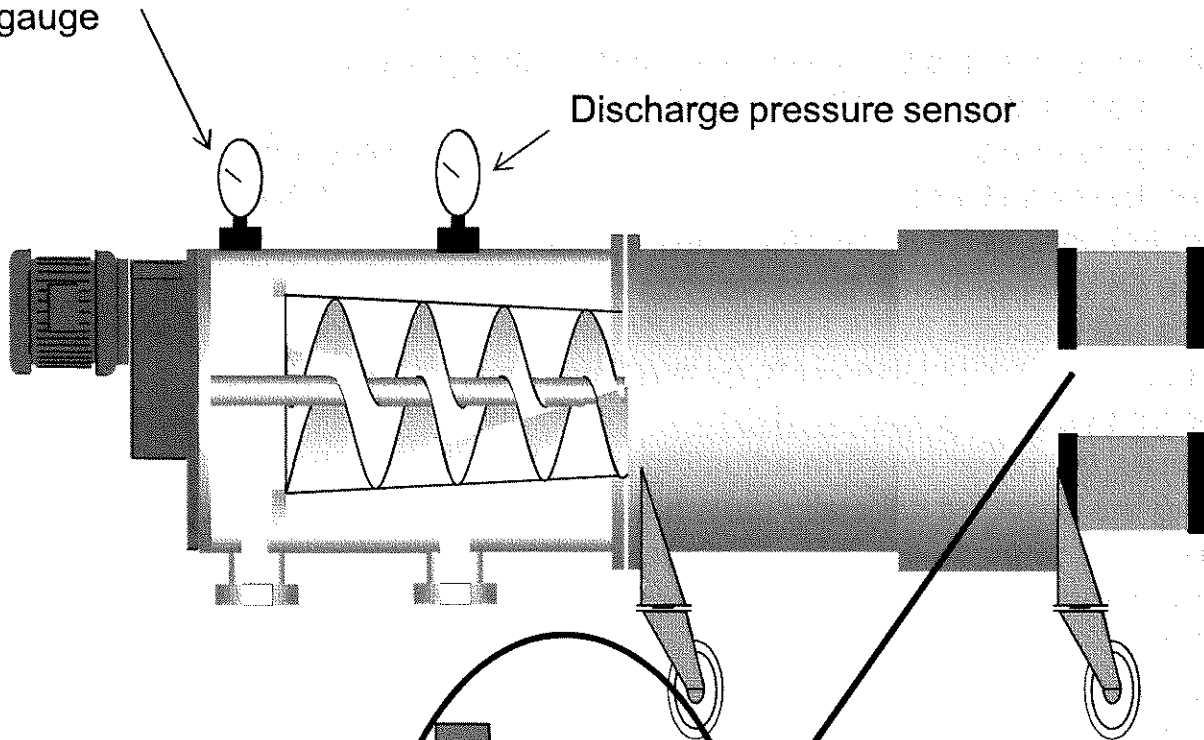

This view shows
the pressure
gauges and
means of
adjustment of
the conveyor
screw

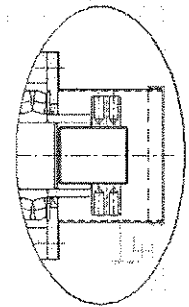
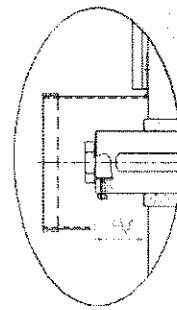
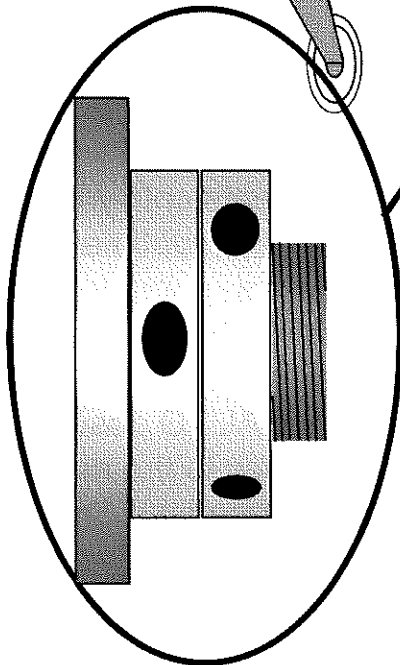

Strainpress External Overview

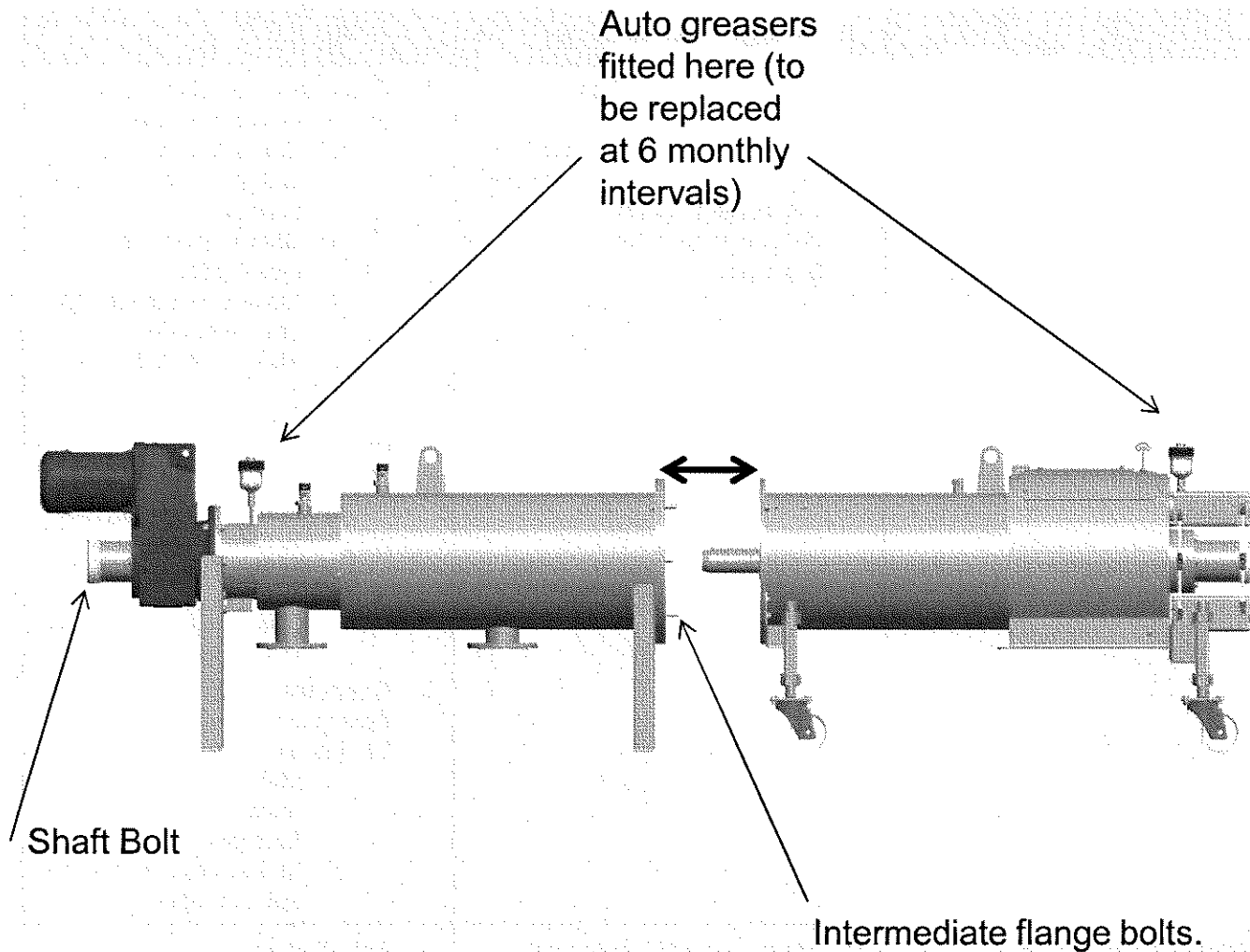

This view shows the location of the grease points, the shaft bolt and intermediate flange bolts

Troubleshooting

Symptoms	Probable Causes	Possible Solutions
Fault Light is energized.	<ol style="list-style-type: none"> 1. Strainpress motor has overloaded. 2. Strainpress has shut down on maintained high inlet pressure. 3. Discharge pressure has become higher than inlet pressure. 	<ol style="list-style-type: none"> 1. Check that the settings in the power monitor are correct. <ol style="list-style-type: none"> a. Check the power settings in the OIU are correct. b. Check the thermal over-loads. c. Make sure screenings are not too dry. d. Make sure throughput is not too high for sludge DS%. 2. Check that the screw is adjusted. <ol style="list-style-type: none"> a. Make sure throughput is not too high for sludge DS%. b. Make sure discharge valve is open and there is no blockage in pipe. 3. Check that sludge is not flowing in reverse through the Strainpress. <ol style="list-style-type: none"> a. Make sure check valve on discharge is functioning. b. Make sure sensors are set up properly.
Machine runs continuously	<ol style="list-style-type: none"> 1. Screw is out of adjustment. 2. Flow rate is too high for sludge DS%. 3. Start differential pressure is too low. 	<ol style="list-style-type: none"> 1. Adjust screw. 2. Reduce flow rate to acceptable level for sludge concentration. 3. Increase start differential pressure to increase the dwell time.

Troubleshooting(continued)

Symptoms	Probable Causes	Possible Solutions
Pressure does not reduce when machine cycles.	<ol style="list-style-type: none"> 1. Screw is out of adjustment. 2. Throughput is too high for sludge DS%. 3. Blockage in discharge pipe. 	<ol style="list-style-type: none"> 1. Adjust the screw. 2. Reduce throughput to acceptable level for sludge concentration. 3. Check all valves are open and there is no blockage in pipe.
Moisture breakthrough lamp is lit.	<ol style="list-style-type: none"> 1. Cone opens too soon and allows liquid sludge to discharge. 2. More than 17psi across the screens. 3. Overall pressure exceeded. 4. Air pressure has dropped too low. 	<ol style="list-style-type: none"> 1. Increase Strainpress minimum power set point. 2. Check that the screw is adjusted. <ol style="list-style-type: none"> a. Check that throughput is not too high for sludge concentration. 3. Check that the screw is adjusted. <ol style="list-style-type: none"> a. Check that throughput is not too high for sludge concentration. b. Check that all valves are open and there is no blockage in discharge pipe. 4. Check air supply is healthy and all air valves are open. <ol style="list-style-type: none"> a. Check that air lines to cylinders have not become disconnected. b. Make sure manual regulator is set to minimum 75psi. c. Make sure cone directional selector switch is in Forward position.

Troubleshooting(continued)

Symptoms	Probable Causes	Possible Solutions
Screenings are too dry (>50%) causing motor overload.	<ol style="list-style-type: none"> 1. Strainpress minimum power set too low. 2. Machine has been offline for too long while screenings left inside. 3. Cone hold pressure set too high. 4. Dwell time is too long due to extremely low throughput and sludge DS%. 	<ol style="list-style-type: none"> 1. Decrease Strainpress minimum power set point. 2. Split machine and clean. 3. Decrease setting on manual regulator to 75psi. 4. Decrease start differential set point so machine will cycle more frequently.
Screen does not appear to be cleaning after a proper screw adjustment.	<ol style="list-style-type: none"> 1. Screw can no longer be adjusted ($L_H \geq 55\text{mm}$) 2. Non OEM screw and/or screen has been installed. 3. Throughput is too high for sludge DS%. 	<ol style="list-style-type: none"> 1. Purchase and install new Huber OEM screen zone screw. 2. Purchase and install new Huber OEM screen zone screw and/or screen. 3. Reduce throughput to an acceptable level for current sludge concentration.
Sludge throughput is steadily decreasing.	<ol style="list-style-type: none"> 1. The sludge DS%/screenings loading has been increased. 2. Due to wear of the screw the screen is not being cleaned efficiently. 	<ol style="list-style-type: none"> 1. Reduce screenings loading or DS% if higher flows are required. 2. Adjust the screw.
Discharged screenings are too wet. (>35%)	<ol style="list-style-type: none"> 1. Strainpress minimum power set point is too low. 2. Retention cone movement is restricted. 3. Screen is not being cleaned efficiently. 	<ol style="list-style-type: none"> 1. Increase Strainpress minimum power set point. 2. With machine isolated and offline, cycle cone forward and reverse and ensure free movement. 3. Adjust the screw.
Sum of screw adjustment measurements ($L_V + L_H$) has varied.	<ol style="list-style-type: none"> 1. Screw coupling rod is loose. 	<ol style="list-style-type: none"> 1. Tighten screw coupling rod and readjust screw.

Summary of SP4 Sludge Screen Features

- Operates without wash water.
- Flows up to 450 gpm, aperture 3 - 6mm.
- Suitable for pressurised pipelines.
- Screenings discharge pressure regulator for optimum dry product.
- Manufactured entirely from Stainless Steel.
- Throughput (based on 5mm perforations) :
 - 150 gpm @ 8% ds
 - 220 gpm @ 7% ds
 - 260 gpm @ 6% ds
 - 270 gpm @ 5% ds
 - 285 gpm @ 4% ds
 - 330 gpm @ 3% ds

- ** Throughput varies depending upon sludge DS% and amount of screenings > screen basket perforations.

Contact information

Huber Technology Aftermarket Services

North American Headquarters:

Huber Technology Inc.
9735 NorthCross Center Court
Suite A
Huntersville NC 28078

Phone: (704) 949 - 1010
Fax: (704) 949 - 1020
Email: info@hhusa.net

Business Unit Aftermarket Services:

General Service: Phone: (704) 949 - 1015
Scheduling: (704) 990 - 2045
Spare or wear Parts: (704) 949 - 2480
Service Technical Support: Phone: (704) 949 - 1015

Aftermarket Services: E-mail: service@hhusa.net
Spare and/or wear Parts: E-mail: parts@hhusa.net

Or visit our website huber-technology.com for up-to-date information concerning our Business Unit Aftermarket Services.



Huber Technology, Inc.
9735 NorthCross Center, Suite A
Huntersville, NC 28078
www.huber-technology.com