

Reviewers
Frecks

**Wichita ASRII – SWTP & River Intake
 Submittal Review
 52587-3.60.10**

Specification Section: Pad Mount Transformers

Submittal Number: 023

Title: O&M

New Submittal: Resubmittal:

<u>Discipline Review by:</u>	<u>Action Given:</u>	<u>Date:</u>
Civil: _____	_____	_____
Arch: _____	_____	_____
Struct: _____	_____	_____
Process: _____	_____	_____
Mech: _____	_____	_____
Elec: Frecks	A	6/21/11
Geotech: _____	_____	_____

Overall Action Given: A By (Initials): GAF

Note to all disciplines: Reviews must be completed by the date shown below. If multiple reviews are required please complete as soon as possible and route to the next person on the routing order list. Thank you.

Please return this submittal to Rob Alfred by for transmittal.

Wichita Water Utilities

Spec Section 262213 Padmount Transformers
Operation and Maintenance Manual

Factory Order #: 27280249

05/07/1700:00

Wichita, KS

Distributor:
American Electric Co.

Contractor / Installer:
Shelley Electric, Inc.

Consulting Engineer:
Burns & McDonnell Engineering

Steve Vossman
Sales Representative

Paul Pillsbury
Project Manager
North American Operating Division
804-253-0301
paul.pillsbury@us.schneider-electric.com

Make the most of your energySM

Schneider
Electric

Table of Contents

TABLE OF CONTENTS

262213 PADMOUNT TRANSFORMERS

DRAWINGS

SWTP2-AOP-ELC-MVT-010

SWTP2-HSPS-ELC-MVT-010

SWTP2-MF-ELC-MVT-010

SWTP2-MF-ELC-MVT-011

SWTP2-RIV-ELC-MVT-010

SWTP2-SWPS-ELC-MVT-010

MANUAL

Three Phase, Liquid-Filled, Compartmental Type, Pad Mounted Transformers Instruction Bulletin

CERTIFIED TEST REPORTS

SWTP2-RIV-ELC-MVT-010

SWTP2-MF-ELC-MVT-011

SWTP2-MF-ELC-MVT-010

SWTP2-HSPS-ELC-MVT-010

SWTP2-AOP-ELC-MVT-010

SWTP2-SWPS-ELC-MVT-010

COMPONENT LITERATURE

FUSE DATA

Cooper Current Limiting Fuse Part#3544125M71M

Cooper Bay-O-Net Fuse Link Part#4038361C05CB

Cooper Bay-O-Net Fuse Link Part#4000353C14

SURGE ARRESTER

9KV Surge Arrester

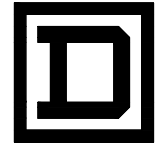

SQUARE D
Schneider Electric

JOB NAME: ASR - PHASE II
JOB LOCATION: HALSTEAD KS

PURCHASER: AMERICAN ELECTRIC CO
PURCHASER PO #: 2-SHEL-09180

USER: WICHITA WATER & SEWER DEPT
USER LOCATION:

DRAWING STATUS: RECORD

SQUARE D QUOTATION NUMBER: 27280249
QUOTATION REVISION #:
SALES CONTACT: R. BURKS
SALES CONTACT LOCATION: 436

CUSTOMER: SHELLEY ELECTRIC, INC.
CUSTOMER PO #:

ARCHITECT: BURNS & MC DONNELL ENGINEERS
CONS. ENGINEER: BURNS & MC DONNELL ENGINEERS

TABLE OF CONTENTS
SQUARE D FACTORY ORDER NUMBER: 27280249-001

EQUIPMENT DESIGNATION:	EQUIPMENT TYPE:	DRAWING TYPE:	DRAWING NUMBER:	PAGE:	REVISION LEVEL:
SWTP2-ADP-ELC-MVT-010	LIQUID FILLED PADMOUNT	ELEVATION	F27280249-001-01-2	2	01
		GENERALNOTE	F27280249-001-01-1	1	01
		RATINGNP	N27280249-001-01-1	1	01
		WIRINGDIAGRAM			

REV: A

REV	DESCRIPTION	BY	DATE	REV	DESCRIPTION	BY	DATE	REV	DESCRIPTION	BY	DATE
01	TEMP RISE CHANGED TO 55/65	SS	090110								

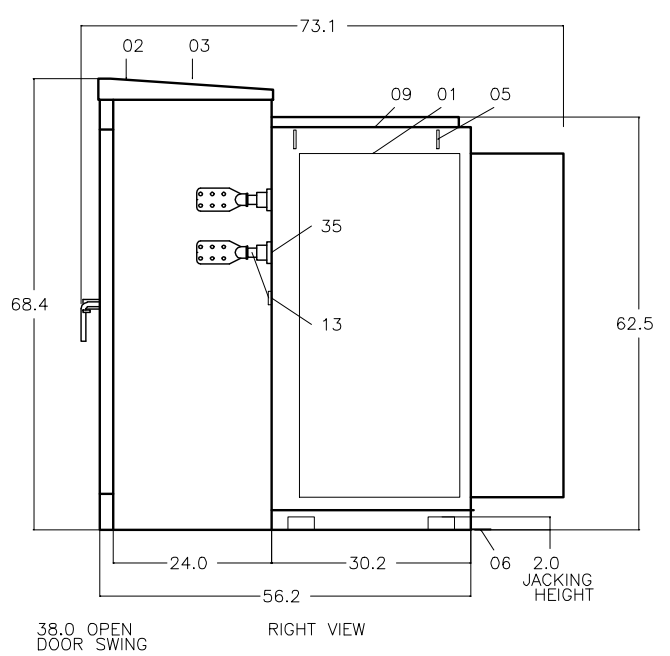
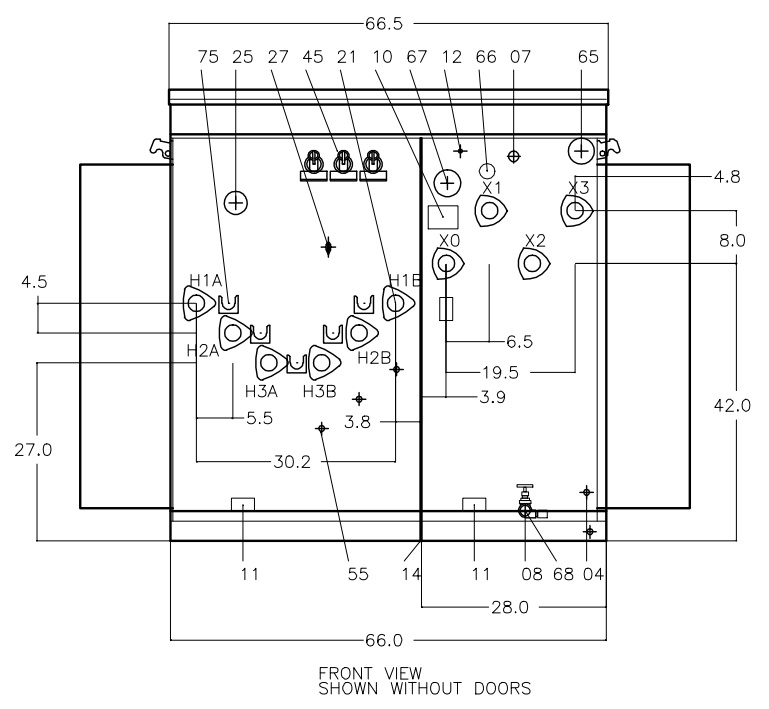
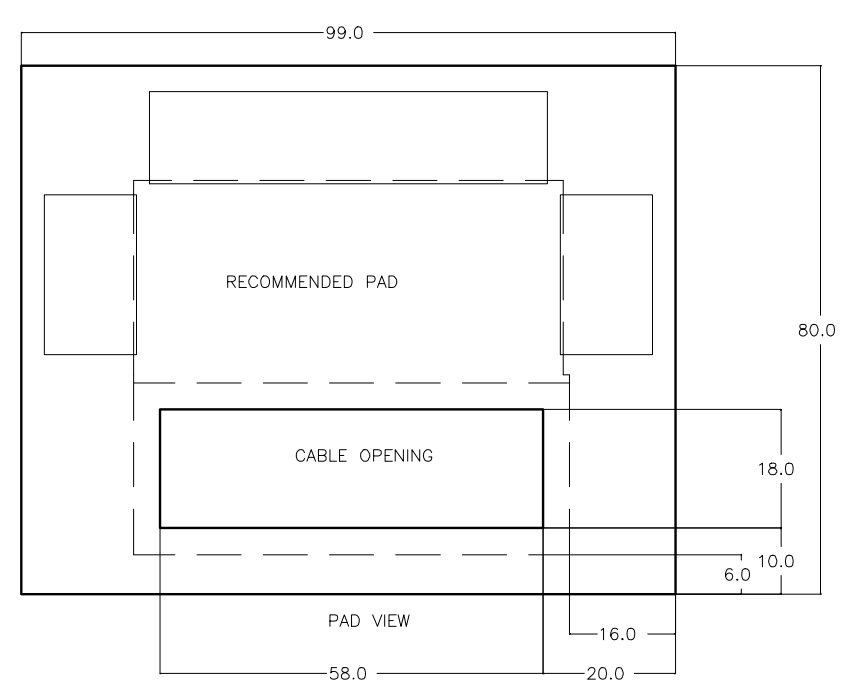
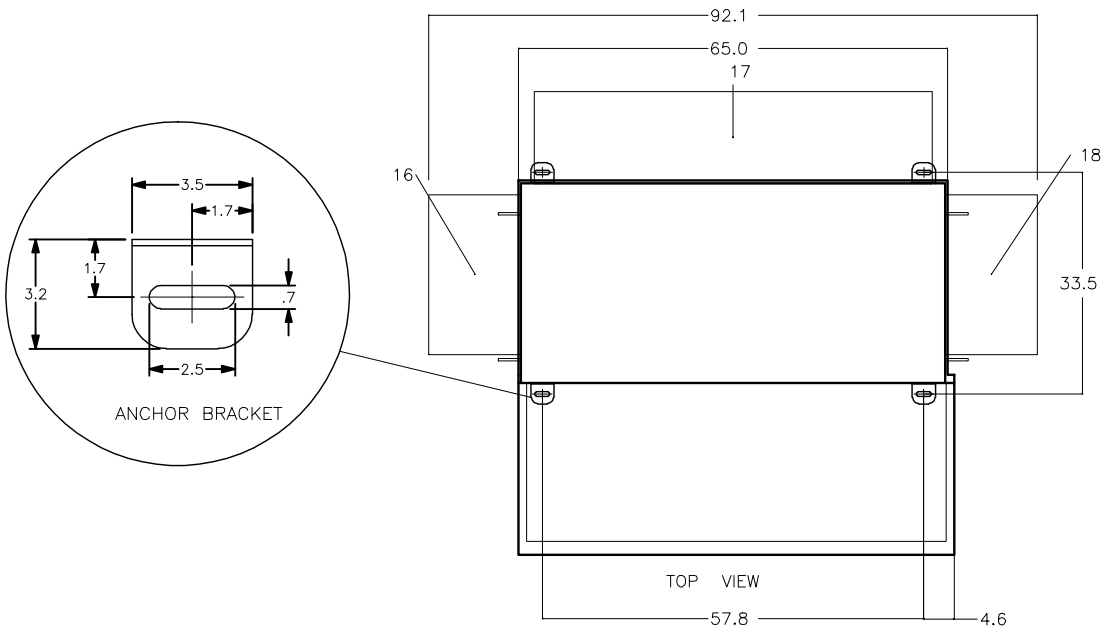

THIS OUTLINE IS FOR ERECTION OR MOUNTING PURPOSES. IT IS NOT TO SCALE AND SHOULD NOT BE REGARDED AS INDICATING THE EXACT DETAILS OF CONSTRUCTION.

- 01 TANK
 - 02 CABINET BOLTED-ON, REMOVABLE SILLS, OPEN BOTTOM 1.25 INCH FLANGE, HINGED LIFT-OFF DOOR, PROVISION FOR PADLOCK, STOP IN OPEN POSITION.
 - 03 WEATHER COVER, REMOVABLE OR HINGED
 - 04 PROVISIONS FOR TANK TO CABINET GROUND
 - 05 LIFTING HOOKS, 4 TOTAL
 - 06 SHIPPING BRACKETS
 - 07 1 INCH FILL PLUG W/ PRESSURE TEST VALVE
 - 08 1 INCH DRAIN PLUG
 - 09 HANDHOLE, 9.5 INCH X 17.5 INCH, BOLTED-ON COVER
 - 10 NAMEPLATE MOUNTED ON TANK WALL
 - 11 GROUND PAD .50-13-TAP, HV AND LV COMPARTMENT
 - 12 PRESSURE RELIEF DEVICE
 - 13 LV NEUTRAL GROUND PAD .50-13-TAP WITH GROUND STRAP
 - 14 HV/LV BARRIER (STEEL)
 - 16 LEFT SIDE COOLER
 - 17 REAR COOLER
 - 18 RIGHT SIDE COOLER
 - 21 HV BUSHING, WELLS 21.1 KV 150 BIL 200 AMP
 - 25 TAP CHANGER
 - 27 LBOR SWITCH, 2 POSITION 38 KV 300 AMP
 - 35 LOW VOLTAGE BUSHING, ANSI SPADES, WITH 6 HOLES
 - 45 DRAWOUT FUSEHOLDERS WITH DRIP SHIELDS
 - 55 ARRESTER MTG GRD PADS - .50-13 TAP
 - 65 PRESSURE VACUUM GAUGE
 - 66 OIL LEVEL GAUGE
 - 67 THERMOMETER
 - 68 DRAIN VALVE WITH SAMPLER
 - 75 PARKING STAND
- ** FUSE LINK - 3544125M71M; COOPER; 15.5KV; 125 AMP PARALLELED
 ** DRAWOUT FUSE - COOPER 125 AMP 4038361C05CB
 ** LOADBREAK INSERTS
 ** 9 KV ELBOW ARRESTERS
 ** UL CERTIFIED
 ** NITROGEN BLANKET
 ** SPARE FUSES
 ** DUAL RATED KVA

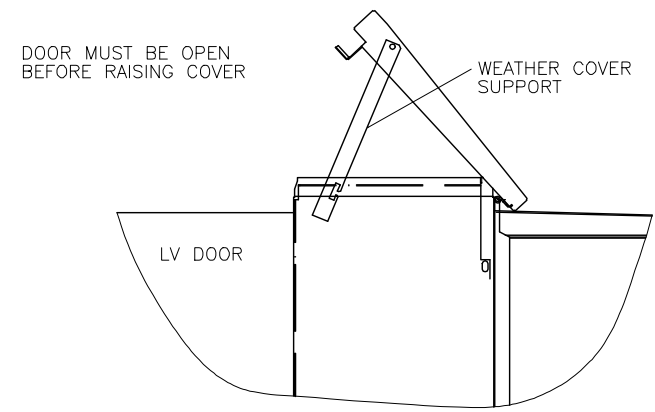

STYLE # F6AE147FWT

ITEM 27: NOTE - LBOR SWITCH RATINGS ARE TYPICAL AND MAXIMUM RATINGS - RATING DETERMINED BY FUSE

JOB NAME: ASR - PHASE II	EQUIPMENT DESIGNATION: SWTP2-AOP-ELC-MVT-010
JOB LOCATION: WICHITA	EQUIPMENT TYPE: LIQUID FILLED TRANSFORMER
DRAWN BY: SAMSON	DRAWING TYPE: OUTLINE
ENGR: SAMSON	
DATE: 090110	
DRAWING STATUS: RECORD	DWG# F27280249-001-01-2

REV	DESCRIPTION	BY	DATE	REV	DESCRIPTION	BY	DATE	REV	DESCRIPTION	BY	DATE
01	TEMP RISE CHANGED TO 55/65	SS	090110								



CLASS ONAN 60 HERTZ
THREE PHASE DISTRIBUTION TRANSFORMER

MADE IN USA

KVA	AT CONTINUOUS RISE C	% IMPEDANCE	SERIAL	MFG DATE	GALLONS OIL	
1500/1680	55/65		99J999999	MMM-YY	412	
HIGH VOLTAGE			HV BIL KV	HV MTL		
12470			95	CU		
LOW VOLTAGE	LV CURRENT	LV BIL KV	LV MTL	TAP CHANGER RATINGS		
480Y/277	1804	30	CU	TAP	VOLTAGE	
<p style="font-size: x-small;">THE 25 C LIQUID LEVEL IS 5.00 INCHES BELOW TOP OF HIGHEST MANHOLE FLANGE. LIQUID LEVEL CHANGES 0.37 INCHES FOR EACH 10 C CHANGE IN AVERAGE LIQUID TEMPERATURE.</p> <p style="font-size: x-small;">MAXIMUM OPERATING PRESSURES OF LIQUID PRESERVATION SYSTEM: 7.00 PSI POSITIVE 7.00 PSI NEGATIVE. TANK DESIGNED FOR 7 PSI VACUUM FILLING.</p> <p style="font-size: x-small;">INSULATING LIQUID: CONTAINS MINERAL OIL WITH NO DETECTABLE LEVEL OF PCB, LESS THAN 1PPM, AT THE TIME OF MANUFACTURE</p> <p style="font-size: x-small;">CAUTION: 1. BEFORE OPERATING READ INSTRUCTION BOOK 43500-054-03R2 2. TANK MUST BE SOLIDLY GROUNDING.</p>		<p style="font-size: x-small;">APPROXIMATE WEIGHTS IN POUNDS</p> <p style="font-size: x-small;">CORE & COILS 4727</p> <p style="font-size: x-small;">OIL 3090</p> <p style="font-size: x-small;">CASE 3262</p> <p style="font-size: x-small;">TOTAL 11079</p>			CURRENT	
				1	13095	66.14
				2	12785	67.74
				3	12470	69.45
				4	12160	71.22
5	11850	73.08				

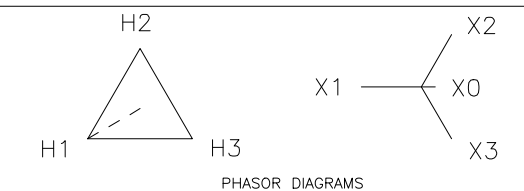

PHASOR DIAGRAMS



LISTED
LIQUID-IMMERSED
DISTRIBUTION TRANSFORMER
16ER FILE NO. E232617

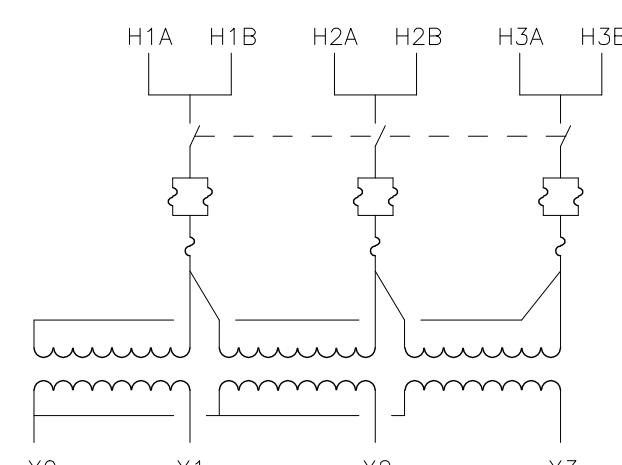

F6AE147FWT
1LUJ

NOTE:
IMPEDANCE, MFG. DATE, AND SERIAL NUMBER WILL BE STAMPED ON NAMEPLATE AFTER FINAL TEST

STYLE # F6AE147FWT

JOB NAME: ASR - PHASE II	EQUIPMENT DESIGNATION: SWTP2-AOP-ELC-MVT-010
JOB LOCATION: WICHITA	EQUIPMENT TYPE: LIQUID FILLED TRANSFORMER
DRAWN BY: SAMSON	DRAWING TYPE: RATED NAMEPLATE
ENGR: SAMSON	
DATE: 090110	
DRAWING STATUS: RECORD	DWG# N27280249-001-01-1

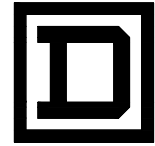

SQUARE D
Schneider Electric

JOB NAME: ASR - PHASE II
JOB LOCATION: HALSTEAD KS

PURCHASER: AMERICAN ELECTRIC CO
PURCHASER PO #: 2-SHEL-09180

USER: WICHITA WATER & SEWER DEPT
USER LOCATION:

DRAWING STATUS: RECORD

SQUARE D QUOTATION NUMBER: 27280249
QUOTATION REVISION #:
SALES CONTACT: R. BURKS
SALES CONTACT LOCATION: 436

CUSTOMER: SHELLEY ELECTRIC, INC.
CUSTOMER PO #:

ARCHITECT: BURNS & MC DONNELL ENGINEERS
CONS. ENGINEER: BURNS & MC DONNELL ENGINEERS

TABLE OF CONTENTS
SQUARE D FACTORY ORDER NUMBER: 27280249-002

EQUIPMENT DESIGNATION:	EQUIPMENT TYPE:	DRAWING TYPE:	DRAWING NUMBER:	PAGE:	REVISION LEVEL:
SWTP2-HSPS-ELC-MVT-010	LIQUID FILLED PADMOUNT	ELEVATION	F27280249-002-01-2	2	-
		GENERALNOTE	F27280249-002-01-1	1	-
		RATINGNP	N27280249-002-01-1	1	-
		WIRINGDIAGRAM			

REV: -

REV	DESCRIPTION	BY	DATE	REV	DESCRIPTION	BY	DATE	REV	DESCRIPTION	BY	DATE
-----	-------------	----	------	-----	-------------	----	------	-----	-------------	----	------

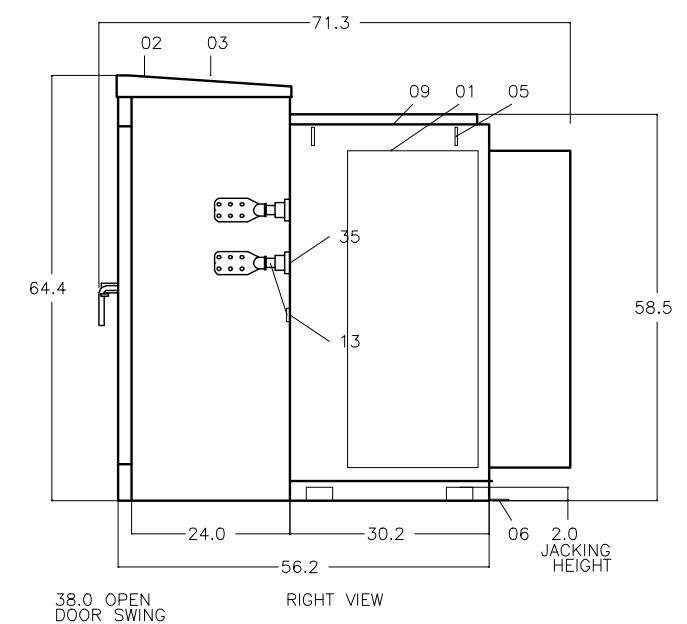
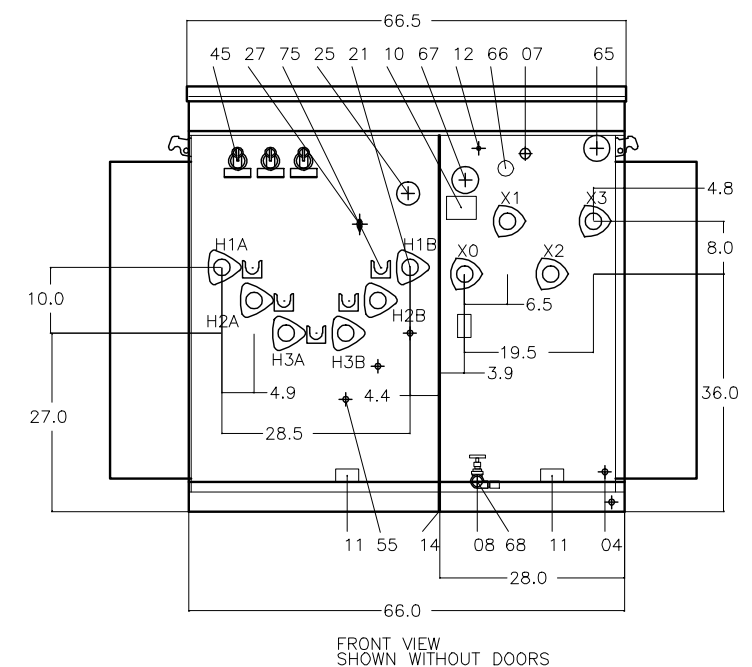
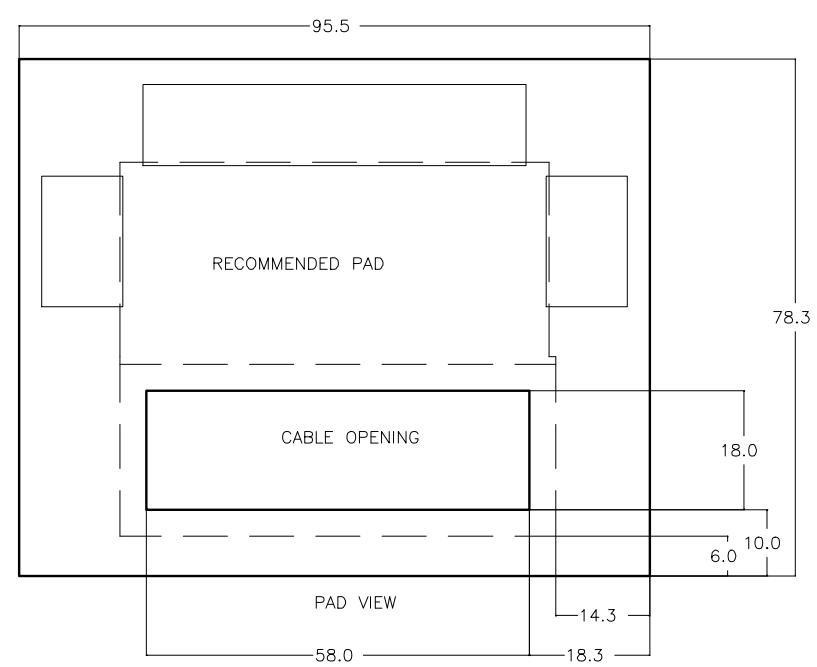
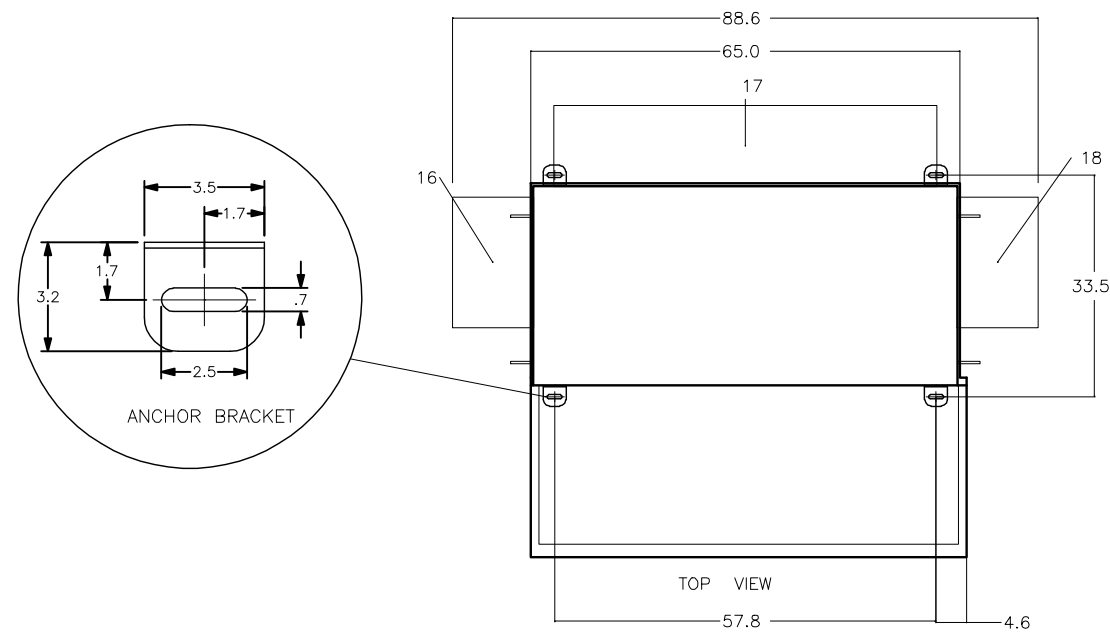

THIS OUTLINE IS FOR ERECTION OR MOUNTING PURPOSES. IT IS NOT TO SCALE AND SHOULD NOT BE REGARDED AS INDICATING THE EXACT DETAILS OF CONSTRUCTION.

- 01 TANK
 - 02 CABINET BOLTED-ON, REMOVABLE SILLS, OPEN BOTTOM 1.25 INCH FLANGE, HINGED LIFT-OFF DOOR, PROVISION FOR PADLOCK, STOP IN OPEN POSITION.
 - 03 WEATHER COVER, REMOVABLE OR HINGED
 - 04 PROVISIONS FOR TANK TO CABINET GROUND
 - 05 LIFTING HOOKS, 4 TOTAL
 - 06 SHIPPING BRACKETS
 - 07 1 INCH FILL PLUG W/ PRESSURE TEST VALVE
 - 08 1 INCH DRAIN PLUG
 - 09 HANDHOLE, 9.5 INCH X 17.5 INCH, BOLTED-ON COVER
 - 10 NAMEPLATE MOUNTED ON TANK WALL
 - 11 GROUND PAD .50-13-TAP, HV AND LV COMPARTMENT
 - 12 PRESSURE RELIEF DEVICE
 - 13 LV NEUTRAL GROUND PAD .50-13-TAP WITH GROUND STRAP
 - 14 HV/LV BARRIER (STEEL)
 - 16 LEFT SIDE COOLER
 - 17 REAR COOLER
 - 18 RIGHT SIDE COOLER
 - 21 HV BUSHING, WELLS 21.1 KV 150 BIL 200 AMP
 - 25 TAP CHANGER
 - 27 LBOR SWITCH, 2 POSITION 38 KV 300 AMP
 - 35 LOW VOLTAGE BUSHING, ANSI SPADES, WITH 6 HOLES
 - 45 DRAWOUT FUSEHOLDERS WITH DRIP SHIELDS
 - 55 ARRESTER MTG GRD PADS - .50-13 TAP
 - 65 PRESSURE VACUUM GAUGE
 - 66 OIL LEVEL GAUGE
 - 67 THERMOMETER
 - 68 DRAIN VALVE WITH SAMPLER
 - 75 PARKING STAND
- ** FUSE LINK - 3544125M71M; COOPER; 15.5KV; 125 AMP PARALLELED
 ** DRAWOUT FUSE - COOPER 125 AMP 4038361C05CB
 ** LOADBREAK INSERTS
 ** 9 KV ELBOW ARRESTERS
 ** NITROGEN BLANKET

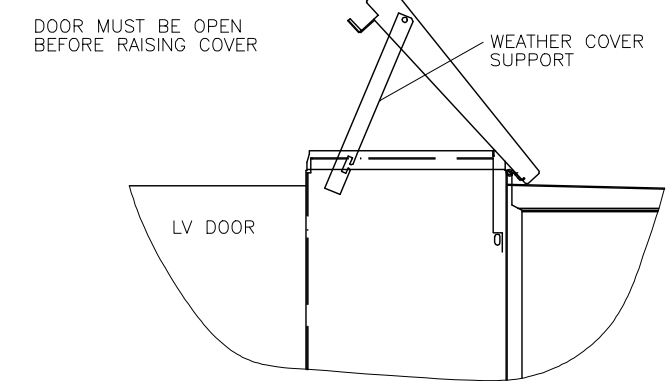

STYLE # F6AE147D5P

ITEM 27: NOTE - LBOR SWITCH RATINGS ARE TYPICAL AND MAXIMUM RATINGS - RATING DETERMINED BY FUSE

JOB NAME: ASR - PHASE II	EQUIPMENT DESIGNATION: SWTP2-HSPS-ELC-MVT-010
JOB LOCATION: WICHITA	EQUIPMENT TYPE: LIQUID FILLED TRANSFORMER
DRAWN BY: SAMSON	DRAWING TYPE: OUTLINE
ENGR: SAMSON	
DATE: 072210	
DRAWING STATUS: RECORD	DWG# F27280249-002-01-2

REV	DESCRIPTION	BY	DATE	REV	DESCRIPTION	BY	DATE	REV	DESCRIPTION	BY	DATE



CLASS ONAN 60 HERTZ
THREE PHASE DISTRIBUTION TRANSFORMER

MADE IN USA

KVA 1500	AT CONTINUOUS RISE C 65	% IMPEDANCE 5.78	SERIAL 99J999999	MFG DATE MMM-YY	GALLONS OIL 368	
HIGH VOLTAGE 12470	LV BIL KV 30		LV MTL CU		HV BIL KV 95	
LOW VOLTAGE 480Y/277	LV CURRENT 1804	TAP CHANGER RATINGS				
<p style="font-size: x-small;">THE 25 C LIQUID LEVEL IS 5.00 INCHES BELOW TOP OF HIGHEST MANHOLE FLANGE. LIQUID LEVEL CHANGES 0.33 INCHES FOR EACH 10 C CHANGE IN AVERAGE LIQUID TEMPERATURE.</p> <p style="font-size: x-small;">MAXIMUM OPERATING PRESSURES OF LIQUID PRESERVATION SYSTEM: 7.00 PSI POSITIVE 7.00 PSI NEGATIVE. TANK DESIGNED FOR 7 PSI VACUUM FILLING.</p> <p style="font-size: x-small;">INSULATING LIQUID: CONTAINS MINERAL OIL WITH NO DETECTABLE LEVEL OF PCB, LESS THAN 1PPM, AT THE TIME OF MANUFACTURE</p> <p style="font-size: x-small;">CAUTION: 1. BEFORE OPERATING READ INSTRUCTION BOOK 43500-054-03R2 2. TANK MUST BE SOLIDLY GROUNDED.</p>		APPROXIMATE WEIGHTS IN POUNDS		TAP	VOLTAGE	CURRENT
		CORE & COILS	4727	1	13095	66.14
		OIL	2760	2	12785	67.74
		CASE	2843	3	12470	69.45
		TOTAL	10330	4	12160	71.22
5	11850	73.08				

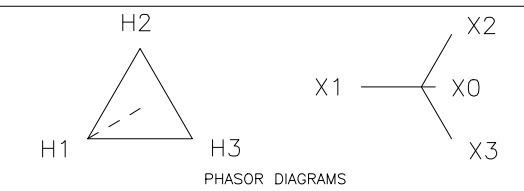

PHASOR DIAGRAMS

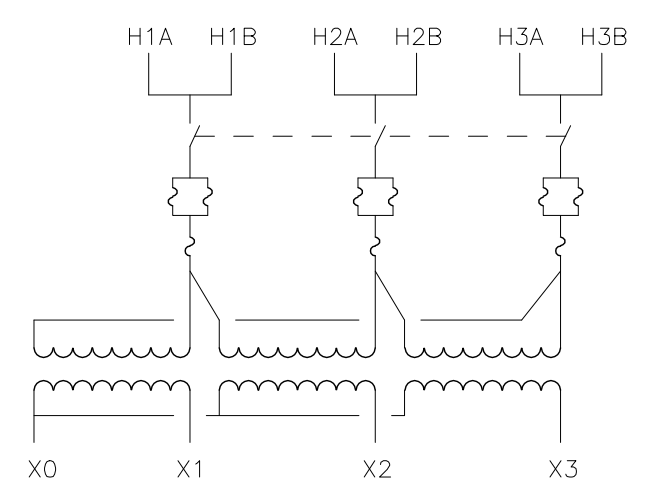

F6AE147D5P
1LUJ

NOTE:
IMPEDANCE, MFG. DATE, AND SERIAL NUMBER WILL BE STAMPED ON NAMEPLATE AFTER FINAL TEST

STYLE # F6AE147D5P

JOB NAME: ASR - PHASE II	EQUIPMENT DESIGNATION: SWTP2-HSPS-ELC-MVT-010
JOB LOCATION: WICHITA	EQUIPMENT TYPE: LIQUID FILLED TRANSFORMER
DRAWN BY: SAMSON	DRAWING TYPE: RATED NAMEPLATE
ENGR: SAMSON	
DATE: 072210	
DRAWING STATUS: RECORD	DWG# N27280249-002-01-1

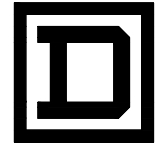

SQUARE D
Schneider Electric

JOB NAME: ASR - PHASE II
JOB LOCATION: HALSTEAD KS

PURCHASER: AMERICAN ELECTRIC CO
PURCHASER PO #: 2-SHEL-09180

USER: WICHITA WATER & SEWER DEPT
USER LOCATION:

DRAWING STATUS: RECORD

SQUARE D QUOTATION NUMBER: 27280249
QUOTATION REVISION #:
SALES CONTACT: R. BURKS
SALES CONTACT LOCATION: 436

CUSTOMER: SHELLEY ELECTRIC, INC.
CUSTOMER PO #:

ARCHITECT: BURNS & MC DONNELL ENGINEERS
CONS. ENGINEER: BURNS & MC DONNELL ENGINEERS

TABLE OF CONTENTS
SQUARE D FACTORY ORDER NUMBER: 27280249-003

EQUIPMENT DESIGNATION:	EQUIPMENT TYPE:	DRAWING TYPE:	DRAWING NUMBER:	PAGE:	REVISION LEVEL:
SWTP2-MF-ELC-MVT-010	LIQUID FILLED PADMOUNT	ELEVATION	F27280249-003-01-2	2	-
		GENERALNOTE	F27280249-003-01-1	1	-
		RATINGNP	N27280249-003-01-1	1	-
		WIRINGDIAGRAM			

REV: -

REV	DESCRIPTION	BY	DATE	REV	DESCRIPTION	BY	DATE	REV	DESCRIPTION	BY	DATE
-----	-------------	----	------	-----	-------------	----	------	-----	-------------	----	------

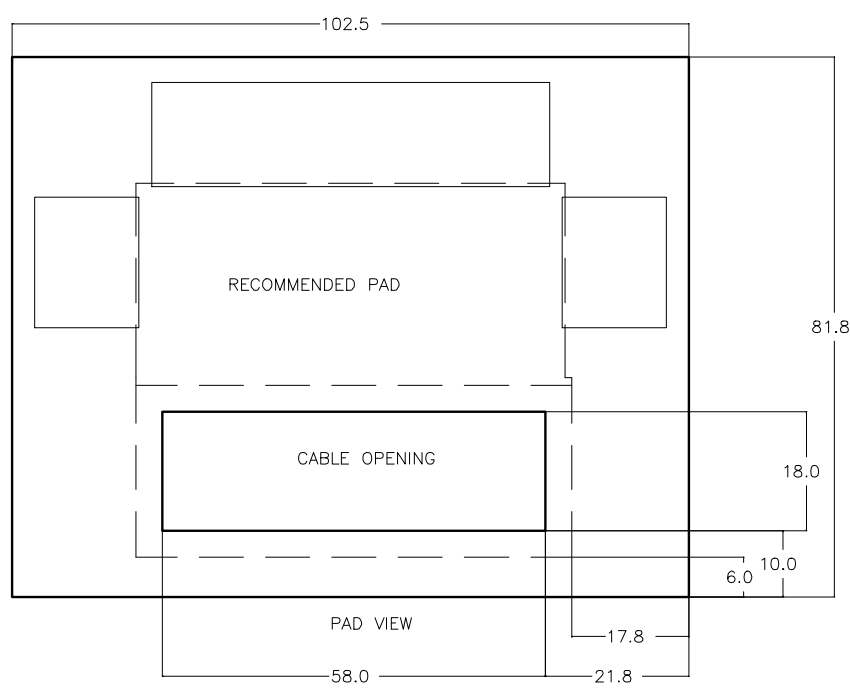
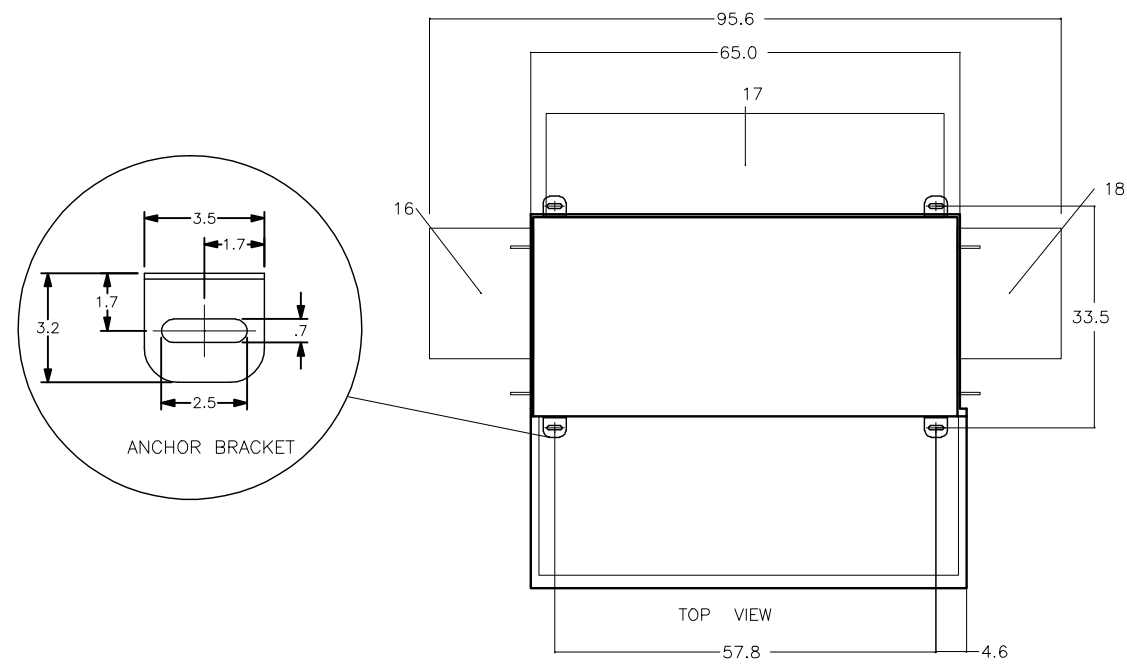

THIS OUTLINE IS FOR ERECTION OR MOUNTING PURPOSES. IT IS NOT TO SCALE AND SHOULD NOT BE REGARDED AS INDICATING THE EXACT DETAILS OF CONSTRUCTION.

- 01 TANK
 - 02 CABINET BOLTED-ON, REMOVABLE SILLS, OPEN BOTTOM 1.25 INCH FLANGE, HINGED LIFT-OFF DOOR, PROVISION FOR PADLOCK, STOP IN OPEN POSITION.
 - 03 WEATHER COVER, REMOVABLE OR HINGED
 - 04 PROVISIONS FOR TANK TO CABINET GROUND
 - 05 LIFTING HOOKS, 4 TOTAL
 - 06 SHIPPING BRACKETS
 - 07 1 INCH FILL PLUG W/ PRESSURE TEST VALVE
 - 08 1 INCH DRAIN PLUG
 - 09 HANDHOLE, 9.5 INCH X 17.5 INCH, BOLTED-ON COVER
 - 10 NAMEPLATE MOUNTED ON TANK WALL
 - 11 GROUND PAD .50-13-TAP, HV AND LV COMPARTMENT
 - 12 PRESSURE RELIEF DEVICE
 - 13 LV NEUTRAL GROUND PAD .50-13-TAP WITH GROUND STRAP
 - 14 HV/LV BARRIER (STEEL)
 - 16 LEFT SIDE COOLER
 - 17 REAR COOLER
 - 18 RIGHT SIDE COOLER
 - 21 HV BUSHING, WELLS 21.1 KV 150 BIL 200 AMP
 - 25 TAP CHANGER
 - 27 LBOR SWITCH, 2 POSITION 38 KV 300 AMP
 - 35 LOW VOLTAGE BUSHING, ANSI SPADES, WITH 6 HOLES
 - 45 DRAWOUT FUSEHOLDERS WITH DRIP SHIELDS
 - 65 PRESSURE VACUUM GAUGE
 - 66 OIL LEVEL GAUGE
 - 67 THERMOMETER
 - 68 DRAIN VALVE WITH SAMPLER
 - 75 PARKING STAND
- ** FUSE LINK - 3544125M71M; COOPER; 15.5KV; 125 AMP PARALLELED
 ** DRAWOUT FUSE - COOPER 125 AMP 4038361C05CB
 ** LOADBREAK INSERTS
 ** NITROGEN BLANKET

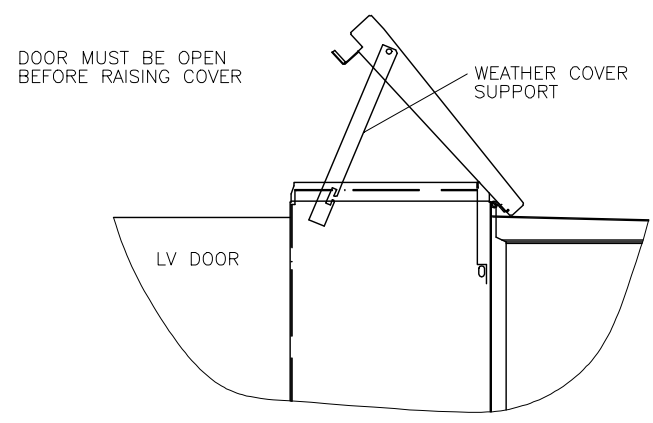
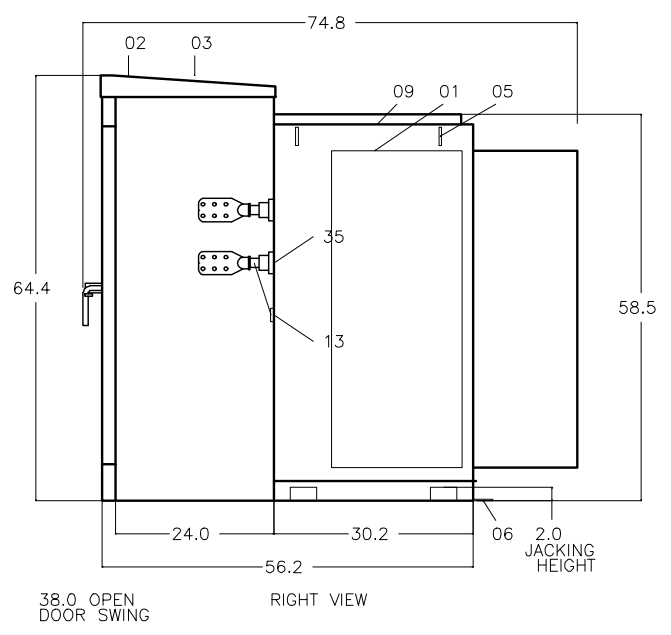
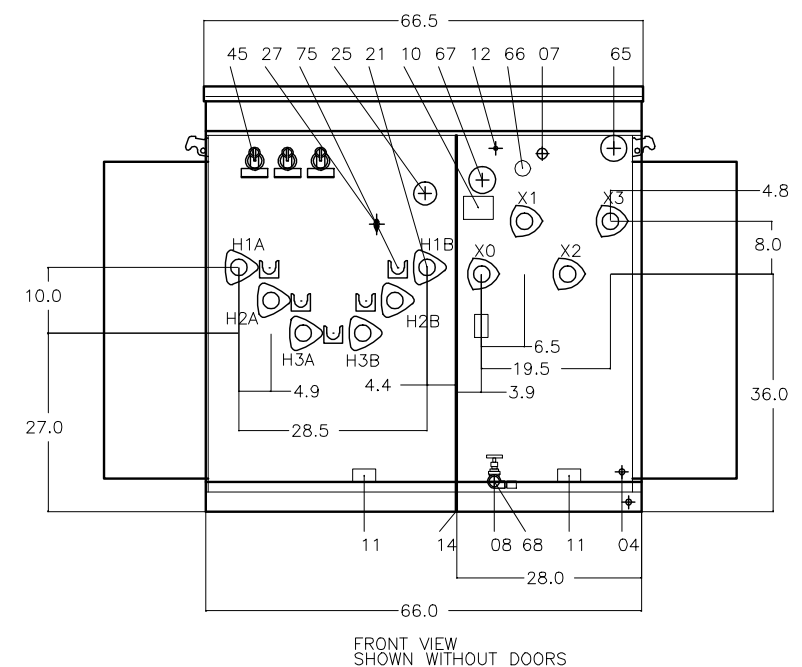

STYLE # F6AE147D5Q

ITEM 27: NOTE - LBOR SWITCH RATINGS ARE TYPICAL AND MAXIMUM RATINGS - RATING DETERMINED BY FUSE

JOB NAME: ASR - PHASE II	EQUIPMENT DESIGNATION: SWTP2-MF-ELC-MVT-010
JOB LOCATION: WICHITA	EQUIPMENT TYPE: LIQUID FILLED TRANSFORMER
DRAWN BY: SAMSON	DRAWING TYPE: OUTLINE
ENGR: SAMSON	
DATE: 072210	
DRAWING STATUS: RECORD	DWG# F27280249-003-01-2

REV	DESCRIPTION	BY	DATE	REV	DESCRIPTION	BY	DATE	REV	DESCRIPTION	BY	DATE
-----	-------------	----	------	-----	-------------	----	------	-----	-------------	----	------

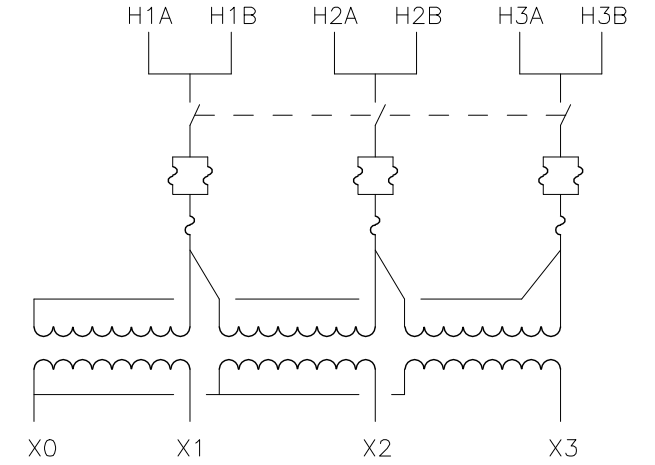
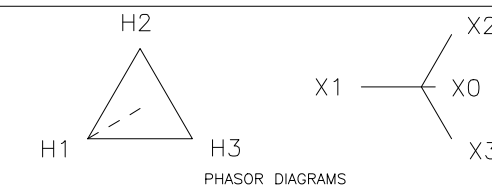

CLASS ONAN 60 HERTZ
THREE PHASE DISTRIBUTION TRANSFORMER

KVA	AT CONTINUOUS RISE C	% IMPEDANCE	SERIAL	MFG DATE	GALLONS OIL
1500/1680	55/65	5.78	99J999999	MMM-YY	376
HIGH VOLTAGE			HV BIL KV	HV MTL	
12470			95	CU	
LOW VOLTAGE		LV CURRENT	LV BIL KV	LV MTL	
480Y/277		1804	30	CU	
<small>THE 25 C LIQUID LEVEL IS 5.00 INCHES BELOW TOP OF HIGHEST MANHOLE FLANGE. LIQUID LEVEL CHANGES 0.34 INCHES FOR EACH 10 C CHANGE IN AVERAGE LIQUID TEMPERATURE.</small>		<small>APPROXIMATE WEIGHTS IN POUNDS</small>		<small>TAP CHANGER RATINGS</small>	
<small>MAXIMUM OPERATING PRESSURES OF LIQUID PRESERVATION SYSTEM: 7.00 PSI POSITIVE 7.00 PSI NEGATIVE. TANK DESIGNED FOR 7 PSI VACUUM FILLING.</small>		<small>CORE & COILS</small> 4727	<small>OIL</small> 2820	<small>CASE</small> 3097	<small>TOTAL</small> 10644
<small>INSULATING LIQUID: CONTAINS MINERAL OIL WITH NO DETECTABLE LEVEL OF PCB, LESS THAN 1PPM, AT THE TIME OF MANUFACTURE</small>		<small>1</small> 13095 66.14 <small>2</small> 12785 67.74 <small>3</small> 12470 69.45 <small>4</small> 12160 71.22 <small>5</small> 11850 73.08			
<small>CAUTION: 1. BEFORE OPERATING READ INSTRUCTION BOOK 43500-054-03R2 2. TANK MUST BE SOLIDLY GROUNDING.</small>					

F6AE147D5Q
1LUJ

NOTE:
IMPEDANCE, MFG. DATE, AND SERIAL NUMBER WILL BE STAMPED ON NAMEPLATE AFTER FINAL TEST

STYLE # F6AE147D5Q

JOB NAME: ASR - PHASE II	EQUIPMENT DESIGNATION: SWTP2-MF-ELC-MVT-010
JOB LOCATION: WICHITA	EQUIPMENT TYPE: LIQUID FILLED TRANSFORMER
DRAWN BY: SAMSON	DRAWING TYPE: RATED NAMEPLATE
ENGR: SAMSON	
DATE: 072210	
DRAWING STATUS: RECORD	DWG# N27280249-003-01-1 PG 1 OF 1 REV -

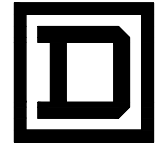

SQUARE D
Schneider Electric

JOB NAME: ASR - PHASE II
JOB LOCATION: HALSTEAD KS

PURCHASER: AMERICAN ELECTRIC CO
PURCHASER PO #: 2-SHEL-09180

USER: WICHITA WATER & SEWER DEPT
USER LOCATION:

DRAWING STATUS: RECORD

SQUARE D QUOTATION NUMBER: 27280249
QUOTATION REVISION #:
SALES CONTACT: R. BURKS
SALES CONTACT LOCATION: 436

CUSTOMER: SHELLEY ELECTRIC, INC.
CUSTOMER PO #:

ARCHITECT: BURNS & MC DONNELL ENGINEERS
CONS. ENGINEER: BURNS & MC DONNELL ENGINEERS

TABLE OF CONTENTS
SQUARE D FACTORY ORDER NUMBER: 27280249-004

EQUIPMENT DESIGNATION:	EQUIPMENT TYPE:	DRAWING TYPE:	DRAWING NUMBER:	PAGE:	REVISION LEVEL:
SWTP2-MF-ELC-MVT-011	LIQUID FILLED PADMOUNT	ELEVATION	F27280249-004-01-2	2	-
		GENERALNOTE	F27280249-004-01-1	1	-
		RATINGNP	N27280249-004-01-1	1	-
		WIRINGDIAGRAM			

REV: -

REV	DESCRIPTION	BY	DATE	REV	DESCRIPTION	BY	DATE	REV	DESCRIPTION	BY	DATE
-----	-------------	----	------	-----	-------------	----	------	-----	-------------	----	------

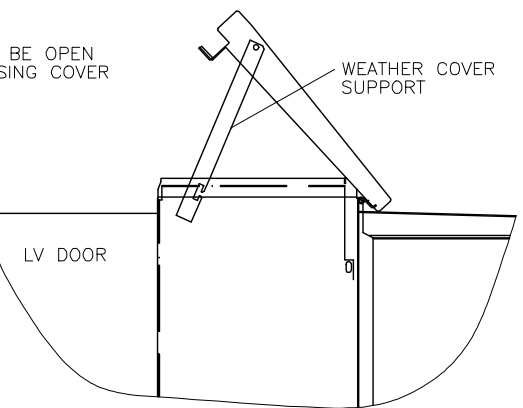
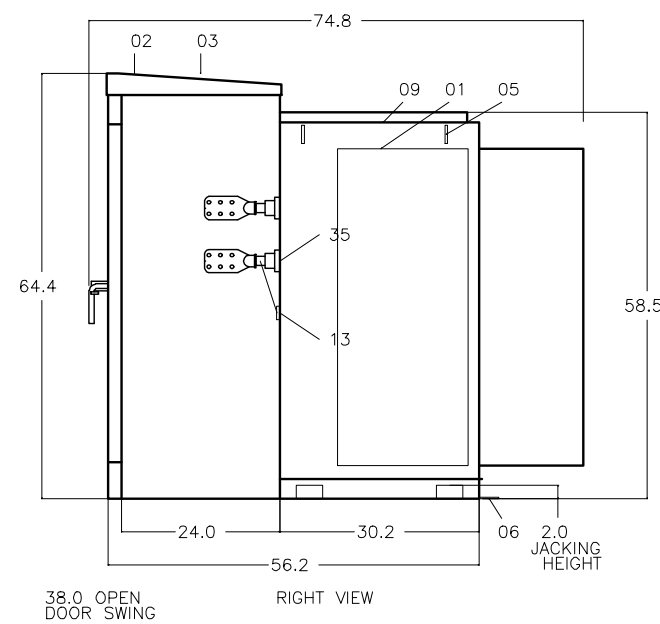
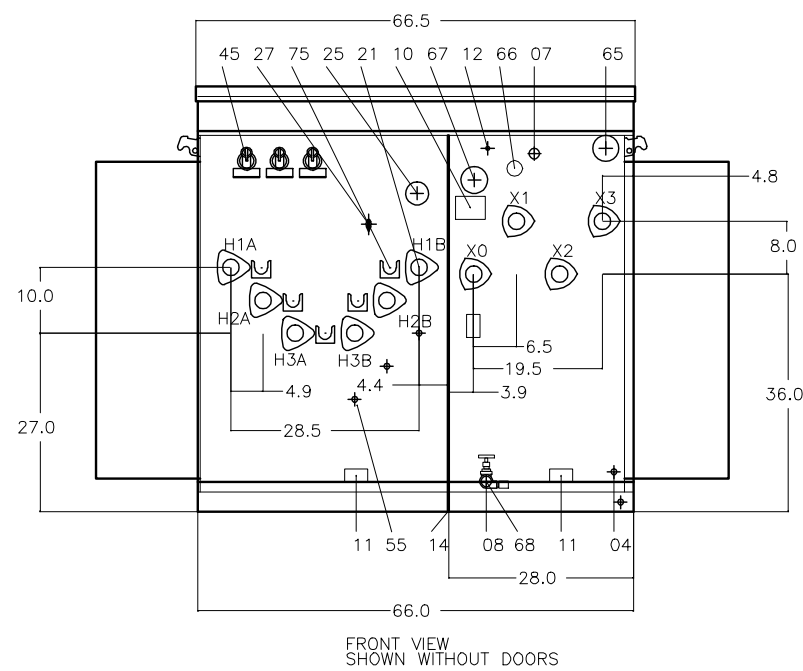
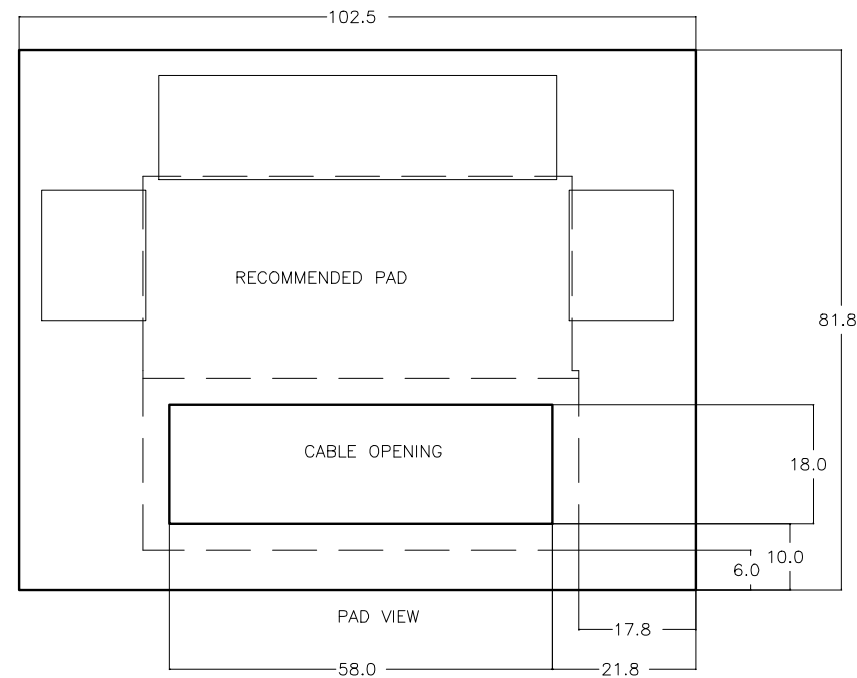
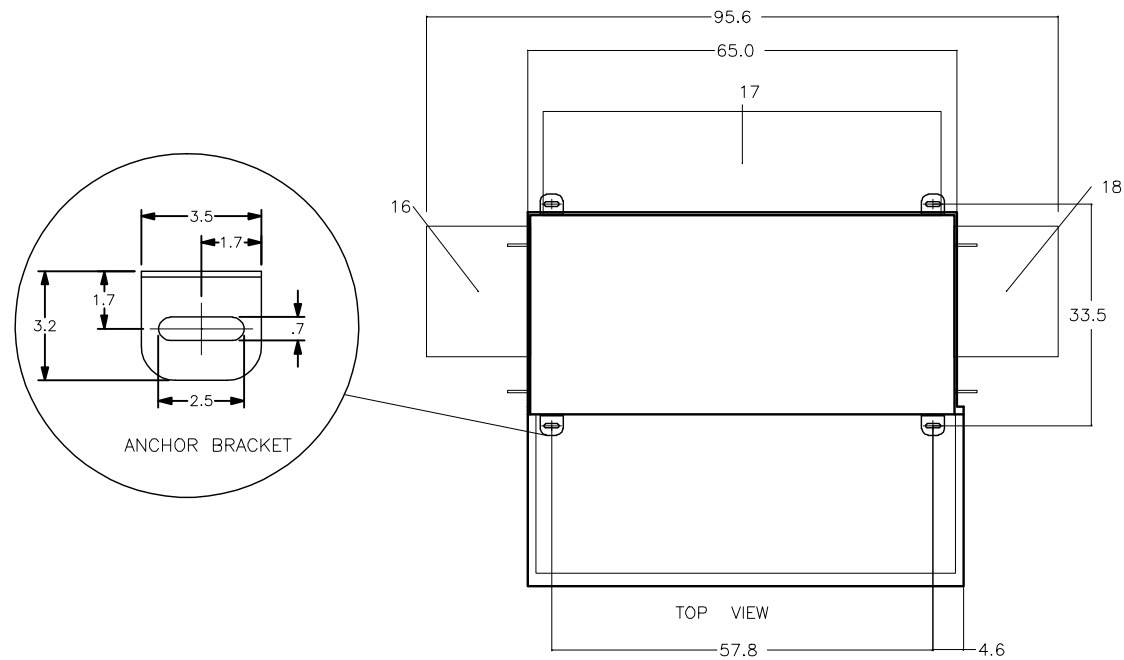

- THIS OUTLINE IS FOR ERECTION OR MOUNTING PURPOSES. IT IS NOT TO SCALE AND SHOULD NOT BE REGARDED AS INDICATING THE EXACT DETAILS OF CONSTRUCTION.
- 01 TANK
 - 02 CABINET BOLTED-ON, REMOVABLE SILLS, OPEN BOTTOM 1.25 INCH FLANGE, HINGED LIFT-OFF DOOR, PROVISION FOR PADLOCK, STOP IN OPEN POSITION.
 - 03 WEATHER COVER, REMOVABLE OR HINGED
 - 04 PROVISIONS FOR TANK TO CABINET GROUND
 - 05 LIFTING HOOKS, 4 TOTAL
 - 06 SHIPPING BRACKETS
 - 07 1 INCH FILL PLUG W/ PRESSURE TEST VALVE
 - 08 1 INCH DRAIN PLUG
 - 09 HANDHOLE, 9.5 INCH X 17.5 INCH, BOLTED-ON COVER
 - 10 NAMEPLATE MOUNTED ON TANK WALL
 - 11 GROUND PAD .50-13-TAP, HV AND LV COMPARTMENT
 - 12 PRESSURE RELIEF DEVICE
 - 13 LV NEUTRAL GROUND PAD .50-13-TAP WITH GROUND STRAP
 - 14 HV/LV BARRIER (STEEL)
 - 16 LEFT SIDE COOLER
 - 17 REAR COOLER
 - 18 RIGHT SIDE COOLER
 - 21 HV BUSHING, WELLS 21.1 KV 150 BIL 200 AMP
 - 25 TAP CHANGER
 - 27 LBOR SWITCH, 2 POSITION 38 KV 300 AMP
 - 35 LOW VOLTAGE BUSHING, ANSI SPADES, WITH 6 HOLES
 - 45 DRAWOUT FUSEHOLDERS WITH DRIP SHIELDS
 - 55 ARRESTER MTG GRD PADS - .50-13 TAP
 - 65 PRESSURE VACUUM GAUGE
 - 66 OIL LEVEL GAUGE
 - 67 THERMOMETER
 - 68 DRAIN VALVE WITH SAMPLER
 - 75 PARKING STAND
- ** FUSE LINK - 3544125M71M; COOPER; 15.5KV; 125 AMP PARALLELED
 ** DRAWOUT FUSE - COOPER 125 AMP 4038361C05CB
 ** LOADBREAK INSERTS
 ** 9 KV ELBOW ARRESTERS
 ** NITROGEN BLANKET

STYLE # F6AE147D5R

ITEM 27: NOTE - LBOR SWITCH RATINGS ARE TYPICAL AND MAXIMUM RATINGS - RATING DETERMINED BY FUSE

JOB NAME: ASR - PHASE II	EQUIPMENT DESIGNATION: SWTP2-MF-ELC-MVT-011
JOB LOCATION: WICHITA	EQUIPMENT TYPE: LIQUID FILLED TRANSFORMER
DRAWN BY: SAMSON	DRAWING TYPE: OUTLINE
ENGR: SAMSON	
DATE: 072210	
DRAWING STATUS: RECORD	DWG# F27280249-004-01-2

REV	DESCRIPTION	BY	DATE	REV	DESCRIPTION	BY	DATE	REV	DESCRIPTION	BY	DATE



CLASS ONAN 60 HERTZ
THREE PHASE DISTRIBUTION TRANSFORMER

MADE IN USA

KVA	AT CONTINUOUS RISE C	% IMPEDANCE	SERIAL	MFG DATE	GALLONS OIL
1500/1680	55/65	5.78	99J999999	MMM-YY	376

HIGH VOLTAGE	LV BIL KV	HV MTL
12470	95	CU

LOW VOLTAGE	LV CURRENT	LV BIL KV	LV MTL	TAP CHANGER RATINGS																		
480Y/277	1804	30	CU	<table border="1" style="width: 100%; border-collapse: collapse;"> <thead> <tr> <th>TAP</th> <th>VOLTAGE</th> <th>CURRENT</th> </tr> </thead> <tbody> <tr><td>1</td><td>13095</td><td>66.14</td></tr> <tr><td>2</td><td>12785</td><td>67.74</td></tr> <tr><td>3</td><td>12470</td><td>69.45</td></tr> <tr><td>4</td><td>12160</td><td>71.22</td></tr> <tr><td>5</td><td>11850</td><td>73.08</td></tr> </tbody> </table>	TAP	VOLTAGE	CURRENT	1	13095	66.14	2	12785	67.74	3	12470	69.45	4	12160	71.22	5	11850	73.08
TAP	VOLTAGE	CURRENT																				
1	13095	66.14																				
2	12785	67.74																				
3	12470	69.45																				
4	12160	71.22																				
5	11850	73.08																				

THE 25 C LIQUID LEVEL IS 5.00 INCHES BELOW TOP OF HIGHEST MANHOLE FLANGE.

LIQUID LEVEL CHANGES 0.34 INCHES FOR EACH 10 C CHANGE IN AVERAGE LIQUID TEMPERATURE.

MAXIMUM OPERATING PRESSURES OF LIQUID PRESERVATION SYSTEM: 7.00 PSI POSITIVE 7.00 PSI NEGATIVE.

TANK DESIGNED FOR 7 PSI VACUUM FILLING.

INSULATING LIQUID: CONTAINS MINERAL OIL WITH NO DETECTABLE LEVEL OF PCB, LESS THAN 1PPM, AT THE TIME OF MANUFACTURE

CAUTION: 1. BEFORE OPERATING READ INSTRUCTION BOOK 43500-054-03R2
2. TANK MUST BE SOLIDLY GROUNDING.

APPROXIMATE WEIGHTS IN POUNDS	CORE & COILS	OIL	CASE	TOTAL
4727	2820	3115	10662	

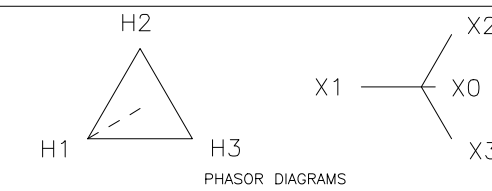

PHASOR DIAGRAMS

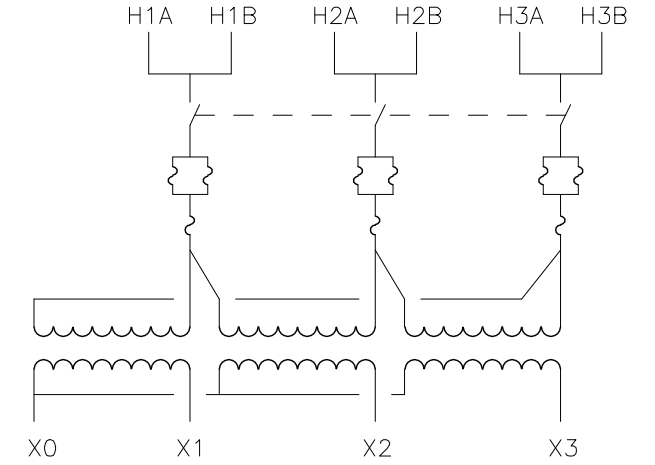

F6AE147D5R
1LUJ

NOTE:
IMPEDANCE, MFG. DATE, AND SERIAL NUMBER WILL BE STAMPED ON NAMEPLATE AFTER FINAL TEST

STYLE # F6AE147D5R

JOB NAME: ASR - PHASE II	EQUIPMENT DESIGNATION: SWTP2-MF-ELC-MVT-011
JOB LOCATION: WICHITA	EQUIPMENT TYPE: LIQUID FILLED TRANSFORMER
DRAWN BY: SAMSON	DRAWING TYPE: RATED NAMEPLATE
ENGR: SAMSON	
DATE: 072210	
DRAWING STATUS: RECORD	DWG# N27280249-004-01-1

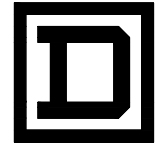

SQUARE D
Schneider Electric

JOB NAME: ASR - PHASE II
JOB LOCATION: HALSTEAD KS

PURCHASER: AMERICAN ELECTRIC CO
PURCHASER PO #: 2-SHEL-09180

USER: WICHITA WATER & SEWER DEPT
USER LOCATION:

DRAWING STATUS: RECORD

SQUARE D QUOTATION NUMBER: 27280249
QUOTATION REVISION #:
SALES CONTACT: R. BURKS
SALES CONTACT LOCATION: 436

CUSTOMER: SHELLEY ELECTRIC, INC.
CUSTOMER PO #:

ARCHITECT: BURNS & MC DONNELL ENGINEERS
CONS. ENGINEER: BURNS & MC DONNELL ENGINEERS

TABLE OF CONTENTS
SQUARE D FACTORY ORDER NUMBER: 27280249-005

EQUIPMENT DESIGNATION:	EQUIPMENT TYPE:	DRAWING TYPE:	DRAWING NUMBER:	PAGE:	REVISION LEVEL:
SWTP2-RIV-ELC-MVT-010	LIQUID FILLED PADMOUNT	ELEVATION	F27280249-005-01-2	2	01
		GENERALNOTE	F27280249-005-01-1	1	-
		RATINGNP	N27280249-005-01-1	1	-
		WIRINGDIAGRAM			

REV: A

REV	DESCRIPTION	BY	DATE	REV	DESCRIPTION	BY	DATE	REV	DESCRIPTION	BY	DATE
01	SWITCHED TO COOPER DRAWOUT FUSE & ADDED ARRESTER CAT #	SS	061410								

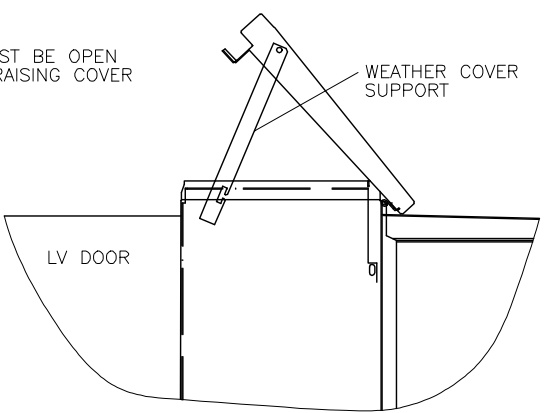
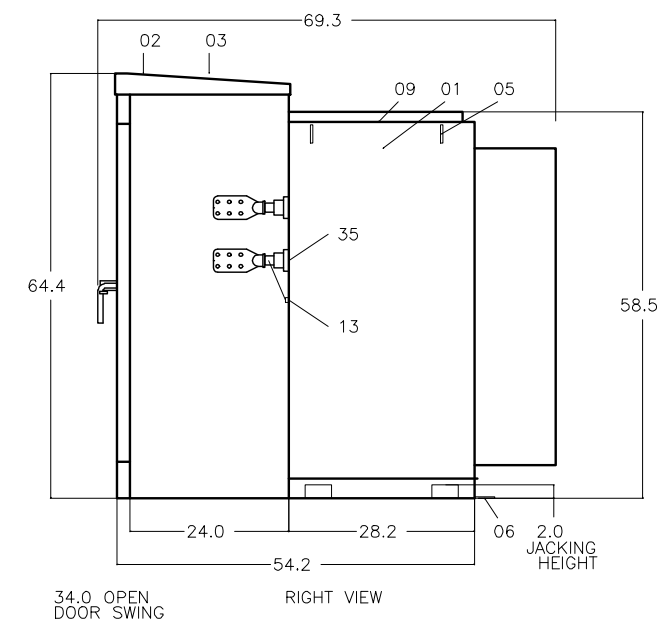
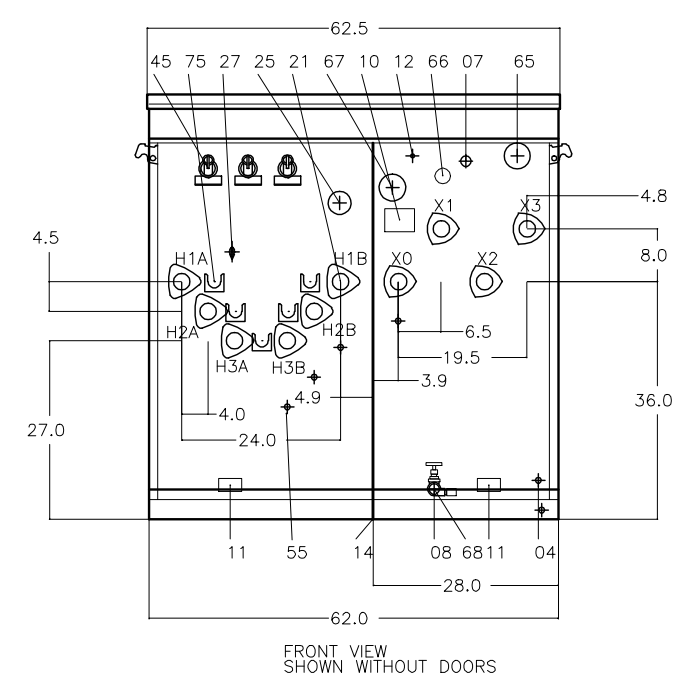
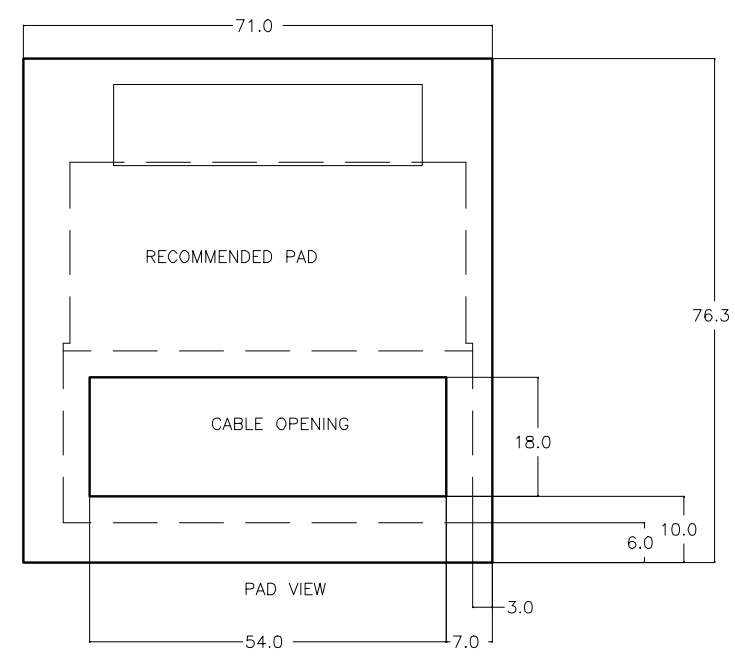
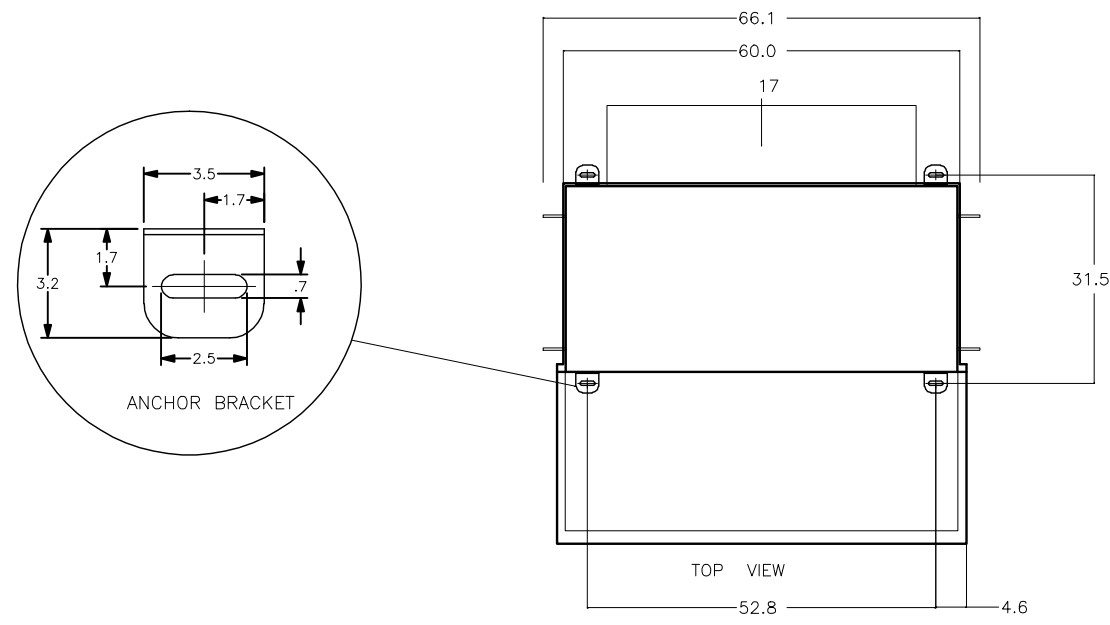

THIS OUTLINE IS FOR ERECTION OR MOUNTING PURPOSES. IT IS NOT TO SCALE AND SHOULD NOT BE REGARDED AS INDICATING THE EXACT DETAILS OF CONSTRUCTION.

- 01 TANK
 - 02 CABINET BOLTED-ON, REMOVABLE SILLS, OPEN BOTTOM 1.25 INCH FLANGE, HINGED LIFT-OFF DOOR, PROVISION FOR PADLOCK, STOP IN OPEN POSITION.
 - 03 WEATHER COVER, REMOVABLE OR HINGED
 - 04 PROVISIONS FOR TANK TO CABINET GROUND
 - 05 LIFTING HOOKS, 4 TOTAL
 - 06 SHIPPING BRACKETS
 - 07 1 INCH FILL PLUG W/ PRESSURE TEST VALVE
 - 08 1 INCH DRAIN PLUG
 - 09 HANDHOLE, 9.5 INCH X 17.5 INCH, BOLTED-ON COVER
 - 10 NAMEPLATE MOUNTED ON TANK WALL
 - 11 GROUND PAD .50-13-TAP, HV AND LV COMPARTMENT
 - 12 PRESSURE RELIEF DEVICE
 - 13 LV NEUTRAL GROUND PAD .50-13-TAP WITH GROUND STRAP
 - 14 HV/LV BARRIER (STEEL)
 - 17 REAR COOLER
 - 21 HV BUSHING, WELLS 21.1 KV 150 BIL 200 AMP
 - 25 TAP CHANGER
 - 27 LBOR SWITCH, 2 POSITION 38 KV 300 AMP
 - 35 LOW VOLTAGE BUSHING, ANSI SPADES, WITH 6 HOLES
 - 45 DRAWOUT FUSEHOLDERS WITH DRIP SHIELDS
 - 55 ARRESTER MTG GRD PADS - .50-13 TAP
 - 65 PRESSURE VACUUM GAUGE
 - 66 OIL LEVEL GAUGE
 - 67 THERMOMETER
 - 68 DRAIN VALVE WITH SAMPLER
 - 75 PARKING STAND
- ** FUSE LINK - 3544125M71M; COOPER; 15.5KV; 125 AMP
 ** DRAWOUT FUSE - COOPER 65AMP CUR SEN 4000353C14
 ** LOADBREAK INSERTS
 ** 9 KV ELBOW ARRESTERS, COOPER 3238018C09M
 ** SPARE FUSES
 ** NITROGEN BLANKET

STYLE # F6AE777D5S

JOB NAME: ASR - PHASE II	EQUIPMENT DESIGNATION: SWTP2-RIV-ELC-MVT-010
JOB LOCATION: WICHITA	EQUIPMENT TYPE: LIQUID FILLED TRANSFORMER
DRAWN BY: SAMSON	DRAWING TYPE: OUTLINE
ENGR: SAMSON	
DATE: 072210	
DRAWING STATUS: RECORD	DWG# F27280249-005-01-2
	PG 1 OF 1
	REV 01

REV	DESCRIPTION	BY	DATE	REV	DESCRIPTION	BY	DATE	REV	DESCRIPTION	BY	DATE
-----	-------------	----	------	-----	-------------	----	------	-----	-------------	----	------



CLASS ONAN 60 HERTZ
THREE PHASE DISTRIBUTION TRANSFORMER

MADE IN USA

KVA	AT CONTINUOUS RISE C	% IMPEDANCE	SERIAL	MFG DATE	GALLONS OIL			
750	65	5.75	99J999999	MMM-YY	330			
HIGH VOLTAGE			HV BIL KV	HV MTL				
12470			95	CU				
LOW VOLTAGE		LV CURRENT	LV BIL KV	LV MTL				
480Y/277		902	30	CU				
<small>THE 25 C LIQUID LEVEL IS 5.00 INCHES BELOW TOP OF HIGHEST MANHOLE FLANGE. LIQUID LEVEL CHANGES 0.34 INCHES FOR EACH 10 C CHANGE IN AVERAGE LIQUID TEMPERATURE.</small> <small>MAXIMUM OPERATING PRESSURES OF LIQUID PRESERVATION SYSTEM: 7.00 PSI POSITIVE 7.00 PSI NEGATIVE. TANK DESIGNED FOR 7 PSI VACUUM FILLING.</small> <small>INSULATING LIQUID: CONTAINS MINERAL OIL WITH NO DETECTABLE LEVEL OF PCB, LESS THAN 1PPM, AT THE TIME OF MANUFACTURE</small> <small>CAUTION: 1. BEFORE OPERATING READ INSTRUCTION BOOK 43500-054-03R2 2. TANK MUST BE SOLIDLY GROUNDLED.</small>		APPROXIMATE WEIGHTS IN POUNDS		TAP CHANGER RATINGS				
		CORE & COILS	OIL	CASE	TOTAL	TAP	VOLTAGE	CURRENT
		2569	2475	2092	7136	1	13095	33.07
						2	12785	33.87
						3	12470	34.73
						4	12160	35.61
						5	11850	36.54

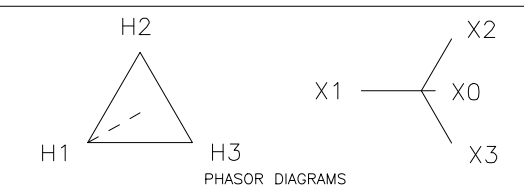

PHASOR DIAGRAMS

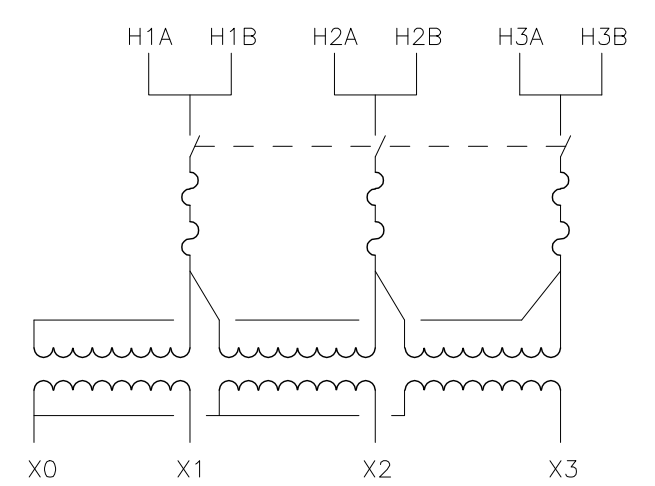

F6AE777D5S
1LUJ

NOTE:
IMPEDANCE, MFG. DATE, AND SERIAL NUMBER WILL BE STAMPED ON NAMEPLATE AFTER FINAL TEST

STYLE # F6AE777D5S

JOB NAME: ASR - PHASE II	EQUIPMENT DESIGNATION: SWTP2-RIV-ELC-MVT-010
JOB LOCATION: WICHITA	EQUIPMENT TYPE: LIQUID FILLED TRANSFORMER
DRAWN BY: SAMSON	DRAWING TYPE: RATED NAMEPLATE
ENGR: SAMSON	
DATE: 072210	
DRAWING STATUS: RECORD	DWG# N27280249-005-01-1

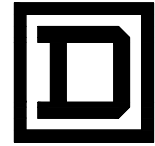

SQUARE D
Schneider Electric

JOB NAME: ASR - PHASE II
JOB LOCATION: HALSTEAD KS

PURCHASER: AMERICAN ELECTRIC CO
PURCHASER PO #: 2-SHEL-09180

USER: WICHITA WATER & SEWER DEPT
USER LOCATION:

DRAWING STATUS: RECORD

SQUARE D QUOTATION NUMBER: 27280249
QUOTATION REVISION #:
SALES CONTACT: R. BURKS
SALES CONTACT LOCATION: 436

CUSTOMER: SHELLEY ELECTRIC, INC.
CUSTOMER PO #:

ARCHITECT: BURNS & MC DONNELL ENGINEERS
CONS. ENGINEER: BURNS & MC DONNELL ENGINEERS

TABLE OF CONTENTS
SQUARE D FACTORY ORDER NUMBER: 27280249-006

EQUIPMENT DESIGNATION:	EQUIPMENT TYPE:	DRAWING TYPE:	DRAWING NUMBER:	PAGE:	REVISION LEVEL:
SWTP2-SWPS-ELC-MVT-010	LIQUID FILLED PADMOUNT	ELEVATION	F27280249-006-01-2	2	02
		GENERALNOTE	F27280249-006-01-1	1	-
		RATINGNP	N27280249-006-01-1	1	-
		WIRINGDIAGRAM			

REV: B

REV	DESCRIPTION	BY	DATE	REV	DESCRIPTION	BY	DATE	REV	DESCRIPTION	BY	DATE
01	SWITCHED TO ABB DRAWOUT FUSE	SS	060910	02	SWITCHED TO COOPER DRAWOUT FUSE & ADDED ARRESTER CAT #	SS	061410				

THIS OUTLINE IS FOR ERECTION OR MOUNTING PURPOSES. IT IS NOT TO SCALE AND SHOULD NOT BE REGARDED AS INDICATING THE EXACT DETAILS OF CONSTRUCTION.

- 01 TANK
 - 02 CABINET BOLTED-ON, REMOVABLE SILLS, OPEN BOTTOM 1.25 INCH FLANGE, HINGED LIFT-OFF DOOR, PROVISION FOR PADLOCK, STOP IN OPEN POSITION.
 - 03 WEATHER COVER, REMOVABLE OR HINGED
 - 04 PROVISIONS FOR TANK TO CABINET GROUND
 - 05 LIFTING HOOKS, 4 TOTAL
 - 06 SHIPPING BRACKETS
 - 07 1 INCH FILL PLUG W/ PRESSURE TEST VALVE
 - 08 1 INCH DRAIN PLUG
 - 09 HANDHOLE, 9.5 INCH X 17.5 INCH, BOLTED-ON COVER
 - 10 NAMEPLATE MOUNTED ON TANK WALL
 - 11 GROUND PAD .50-13-TAP, HV AND LV COMPARTMENT
 - 12 PRESSURE RELIEF DEVICE
 - 13 LV NEUTRAL GROUND PAD .50-13-TAP WITH GROUND STRAP
 - 14 HV/LV BARRIER (STEEL)
 - 17 REAR COOLER
 - 21 HV BUSHING, WELLS 21.1 KV 150 BIL 200 AMP
 - 25 TAP CHANGER
 - 27 LBOR SWITCH, 2 POSITION 38 KV 300 AMP
 - 35 LOW VOLTAGE BUSHING, ANSI SPADES, WITH 6 HOLES
 - 45 DRAWOUT FUSEHOLDERS WITH DRIP SHIELDS
 - 55 ARRESTER MTG GRD PADS - .50-13 TAP
 - 65 PRESSURE VACUUM GAUGE
 - 66 OIL LEVEL GAUGE
 - 67 THERMOMETER
 - 68 DRAIN VALVE WITH SAMPLER
 - 75 PARKING STAND
- ** FUSE LINK - 3544125M71M; COOPER; 15.5KV; 125 AMP
 ** DRAWOUT FUSE - COOPER 65AMP CUR SEN 4000353C14
 ** LOADBREAK INSERTS
 ** 9 KV ELBOW ARRESTERS, COOPER 3238018C09M
 ** NITROGEN BLANKET

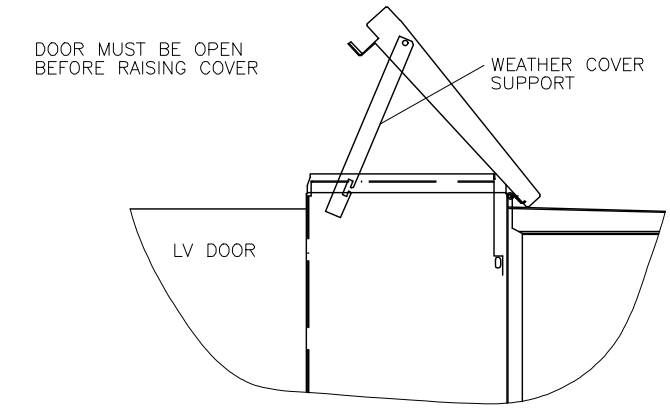
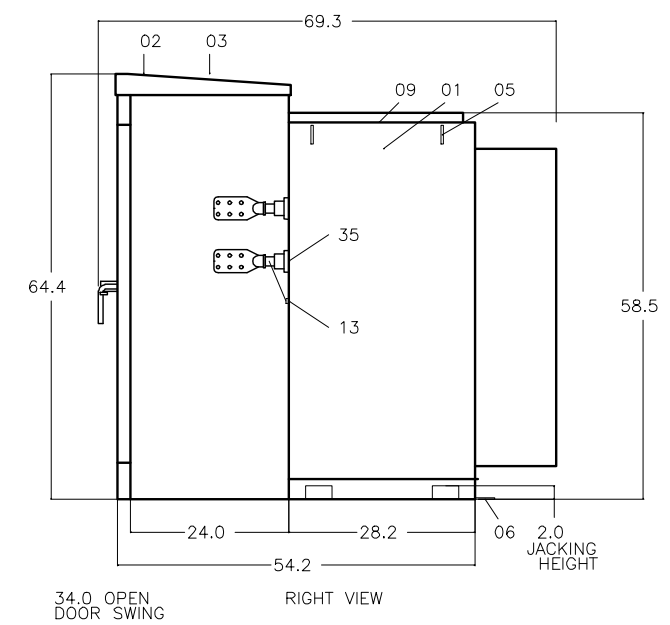
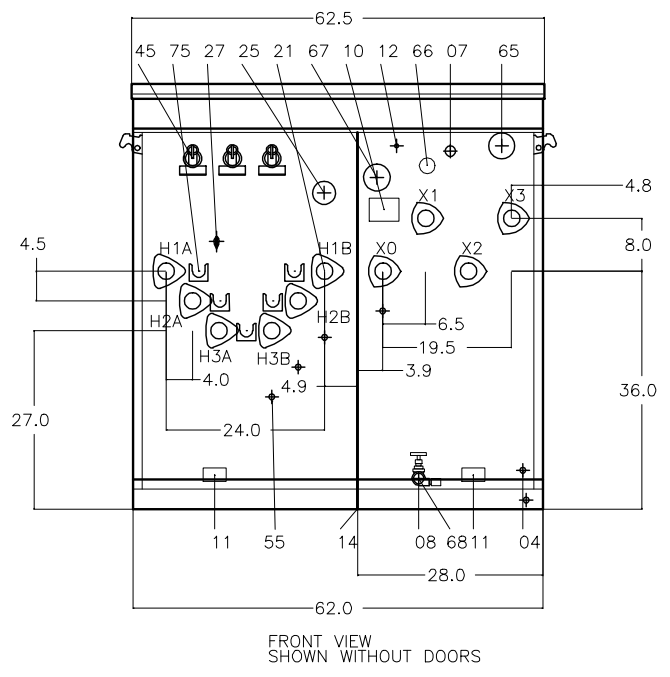
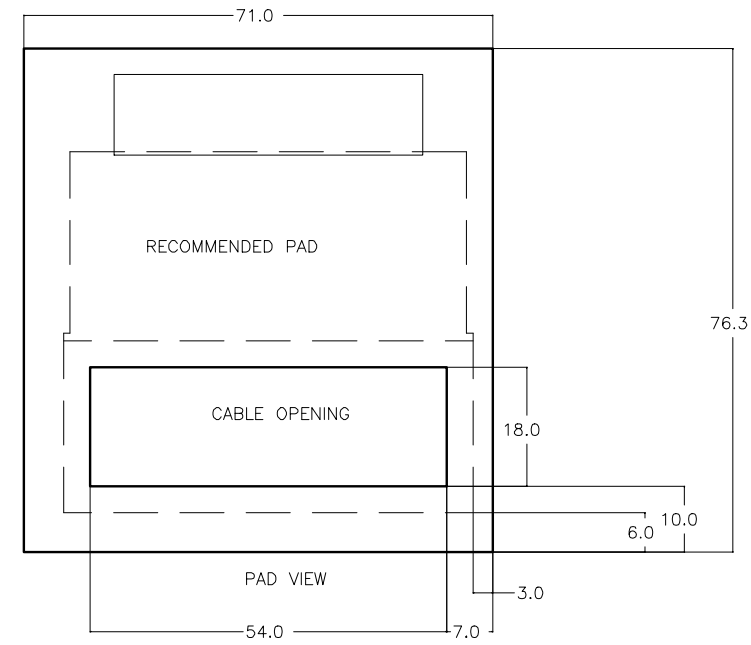
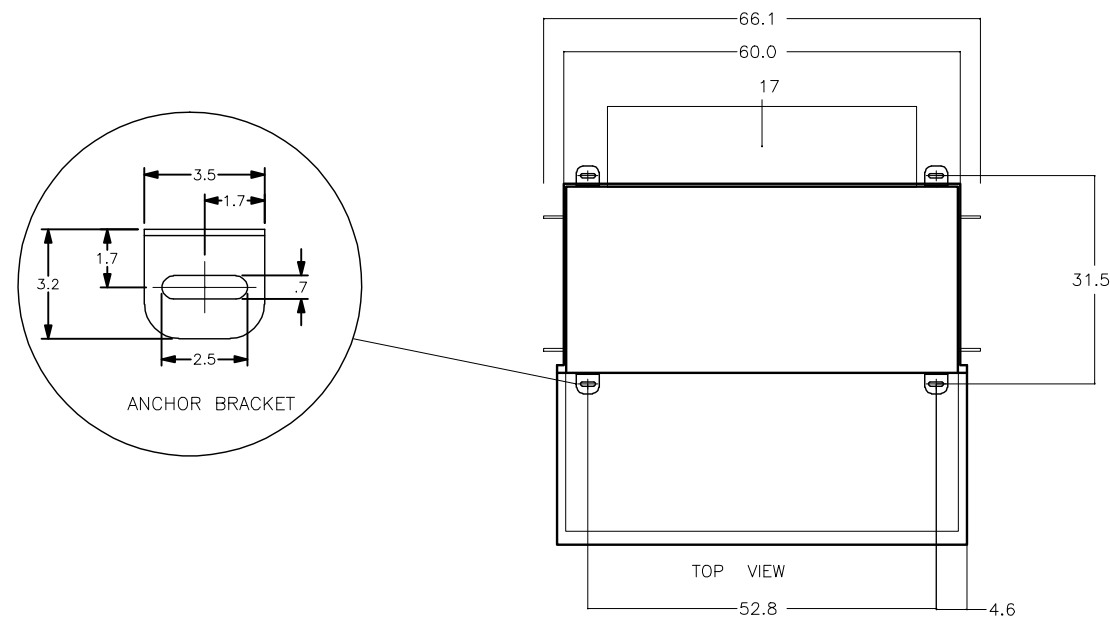

STYLE # F6AE777D5T

JOB NAME: ASR - PHASE II	EQUIPMENT DESIGNATION: SWTP2-SWPS-ELC-MVT-010
JOB LOCATION: WICHITA	EQUIPMENT TYPE: LIQUID FILLED TRANSFORMER
DRAWN BY: SAMSON	DRAWING TYPE: OUTLINE
ENGR: SAMSON	
DATE: 072210	
DRAWING STATUS: RECORD	DWG# F27280249-006-01-2
	PG 1 OF 1
	REV 02

REV	DESCRIPTION	BY	DATE	REV	DESCRIPTION	BY	DATE	REV	DESCRIPTION	BY	DATE



CLASS ONAN 60 HERTZ
THREE PHASE DISTRIBUTION TRANSFORMER

MADE IN USA

KVA 750	AT CONTINUOUS RISE C 65	% IMPEDANCE 5.75	SERIAL 99J999999	MFG DATE MMM-YY	GALLONS OIL 330
HIGH VOLTAGE 12470	HV BIL KV 95	HV MTL CU			
LOW VOLTAGE 480Y/277	LV CURRENT 902	LV BIL KV 30	LV MTL CU		

TAP	TAP CHANGER RATINGS	
	VOLTAGE	CURRENT
1	13095	33.07
2	12785	33.87
3	12470	34.73
4	12160	35.61
5	11850	36.54

THE 25 C LIQUID LEVEL IS 5.00 INCHES BELOW TOP OF HIGHEST MANHOLE FLANGE. LIQUID LEVEL CHANGES 0.34 INCHES FOR EACH 10 C CHANGE IN AVERAGE LIQUID TEMPERATURE.

MAXIMUM OPERATING PRESSURES OF LIQUID PRESERVATION SYSTEM: 7.00 PSI POSITIVE 7.00 PSI NEGATIVE. TANK DESIGNED FOR 7 PSI VACUUM FILLING.

INSULATING LIQUID: CONTAINS MINERAL OIL WITH NO DETECTABLE LEVEL OF PCB, LESS THAN 1PPM, AT THE TIME OF MANUFACTURE

CAUTION: 1. BEFORE OPERATING READ INSTRUCTION BOOK 43500-054-03R2
2. TANK MUST BE SOLIDLY GROUNDING.

APPROXIMATE WEIGHTS IN POUNDS

CORE & COILS 2582

OIL 2475

CASE 2098

TOTAL 7155

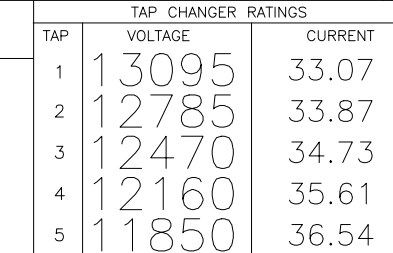

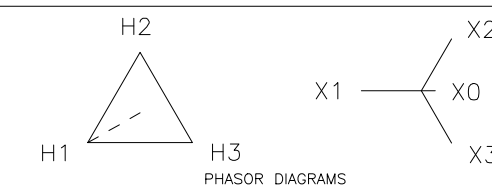

PHASOR DIAGRAMS

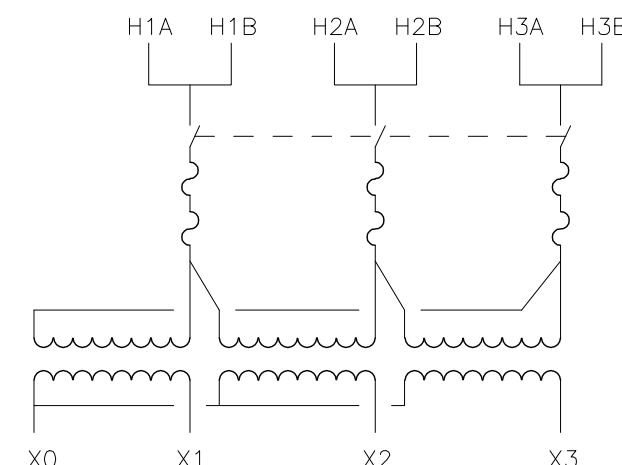

F6AE777D5T
1LUJ

NOTE:
IMPEDANCE, MFG. DATE, AND SERIAL NUMBER WILL BE STAMPED ON NAMEPLATE AFTER FINAL TEST

STYLE # F6AE777D5T

JOB NAME: ASR - PHASE II	EQUIPMENT DESIGNATION: SWTP2-SWPS-ELC-MVT-010
JOB LOCATION: WICHITA	EQUIPMENT TYPE: LIQUID FILLED TRANSFORMER
DRAWN BY: SAMSON	DRAWING TYPE: RATED NAMEPLATE
ENGR: SAMSON	
DATE: 072210	
DRAWING STATUS: RECORD	DWG# N27280249-006-01-1

Three Phase, Liquid Filled, Compartmental Type, Pad Mounted Transformers Class 7230

Instruction Bulletin
Retain for future use.



HAZARD CATEGORIES AND SPECIAL SYMBOLS



Read these instructions carefully and look at the equipment to become familiar with the device before trying to install, operate, service, or maintain it. The following special messages may appear throughout this bulletin or on the equipment to warn of potential hazards or to call attention to information that clarifies or simplifies a procedure.

The addition of either symbol to a “Danger” or “Warning” safety label indicates that an electrical hazard exists which will result in personal injury if the instructions are not followed.

This is the safety alert symbol. It is used to alert you to potential personal injury hazards. Obey all safety messages that follow this symbol to avoid possible injury or death.

⚠ DANGER

DANGER indicates an imminently hazardous situation which, if not avoided, **will result in** death or serious injury.

⚠ WARNING

WARNING indicates a potentially hazardous situation which, if not avoided, **can result in** death or serious injury.

⚠ CAUTION

CAUTION indicates a potentially hazardous situation which, if not avoided, **can result in** minor or moderate injury.

CAUTION

CAUTION, used without the safety alert symbol, indicates a potentially hazardous situation which, if not avoided, **can result in** property damage.

NOTE: Provides additional information to clarify or simplify a procedure.

PLEASE NOTE

Electrical equipment should be installed, operated, serviced, and maintained only by qualified personnel. No responsibility is assumed by Schneider Electric for any consequences arising out of the use of this material.

WARRANTY

WARRANTY TO CUSTOMERS PURCHASING THROUGH AUTHORIZED SCHNEIDER ELECTRIC DISTRIBUTORS AND CUSTOMERS PURCHASING DIRECTLY FROM SCHNEIDER ELECTRIC.

Schneider Electric warrants equipment manufactured by it to be free from defects in materials and workmanship for eighteen (18) months from date of invoice from Schneider Electric or its authorized sales channels. If within the applicable warranty period purchaser discovers such item was not as warranted and promptly notifies Schneider Electric in writing, Schneider Electric shall repair or replace the items or refund the purchase price, at Schneider Electric's option. This warranty shall not apply (a) to equipment not manufactured by Schneider Electric, (b) to equipment which shall have been repaired or altered by others than Schneider Electric, (c) to equipment which shall have been subjected to negligence, accident, or damage by circumstances beyond Schneider Electric's control, or to improper operation, maintenance or storage, or to other than normal use or service. With respect to equipment sold but not manufactured by Schneider Electric, the warranty obligations of Schneider Electric shall in all respects conform and be limited to the warranty actually extended to Schneider Electric by its supplier. The foregoing warranties do not cover reimbursement for labor, transportation, removal, installation, or other expenses which may be incurred in connection with repair or replacement.

Except as may be expressly provided in an authorized writing by Schneider Electric, Schneider Electric shall not be subject to any other obligations or liabilities whatsoever with respect to equipment manufactured by Schneider Electric or services rendered by Schneider Electric.

THE FOREGOING WARRANTIES ARE EXCLUSIVE AND IN LIEU OF ALL OTHER EXPRESS AND IMPLIED WARRANTIES EXCEPT WARRANTIES OF TITLE, INCLUDING BUT NOT LIMITED TO IMPLIED WARRANTIES OF MERCHANTABILITY AND FITNESS FOR A PARTICULAR PURPOSE.

TABLE OF CONTENTS

- Section 1—Standard Features** 5
- Section 2—Introduction** 6
- Section 3— Safety Precautions** 7
- Section 4—Receiving, Handling, and Storage** 8
 - Receiving 8
 - Initial Inspection 8
 - Internal Inspection 9
 - Liquid Sampling 9
 - Liquid Level Inspection 9
 - Handling 10
 - Unloading and Lifting 10
 - Storing 11
- Section 5—Installation** 12
 - Transformer Location 12
 - Restricting Access to the Transformer 12
 - Grounding 13
 - Conduit Area 13
 - Cable Pulling 13
 - Cable Terminations Using Unshielded Cable 13
 - Cable Terminations Using Shielded Cable 14
 - Electrical Connections 14
 - High Voltage Bushing Connections 15
 - Low Voltage Bushing Connections 16
- Section 6—Operation** 16
 - Tap Changer 16
 - Dual Voltage or Delta/Wye Switch Operation 17
 - Parking Stands 17
 - Live-Line Tools (Hot Sticks) 18
 - Load Break Switch Operation 18
 - Fuses 19
 - Bay-O-Net Fuse Operation 19
 - Dry Well Canister Fuse Operation 21
 - Load-Break Fuse Operation 21
 - Non-Load-Break Fuse Operation 21
 - Internal Partial Range Current-Limiting Fuse 22
 - Arc-Strangler Switch Operation 22
 - Weak Link Fuses 23
 - S & C Fused Switch 23
 - Accessories 23
 - Dial Thermometer 23
 - Liquid Level Gauge 24
 - Pressure Vacuum Gauge 24
 - Pressure Relief Valve 24
 - Drain Valve With Sampler 25
 - Surge Arrestors 25
 - Current Transformers 25
 - Molded Case Circuit Breakers 25
- Section 7—Start-Up Testing** 26
 - Pre-energization Tests 26
 - Wye-Wye Transformers With HOXO Bushing 26
 - Insulation Resistance Testing 26
 - Turns Ratio Test 27

Pre-Energizing Procedure Checklist	27
Verifying the Voltage is Correct	29
Inspection Following Energizing	29
Sound Level	29
Cabinet Security	30
Section 8—Maintenance	30
Scheduled Maintenance	30
Maintenance Testing.....	31
Maintenance for Accessories	31
Molded Case Circuit Breakers Inspection and Maintenance	31
Ground Fault Protection Systems	32
Maintenance After a Major Fault	32
Exterior Finish	33
Locating Pressure Leaks Above the Liquid Level.....	33
Liquid Leaks	33
Small Pin-Hole Leaks	34
Bushing Leaks	34
Maintenance of Internal Features	34
Sampling the Liquid	34
Receiving, Storing, and Handling the Liquid.....	35
Draining and Filling the Tank	35
Opening the Transformer Tank.....	36
Entering the Transformer Tank.....	37
Closing the Transformer Tank	37
Repairs	37
Section 9—Replacement Parts	38
Section 10—Reference Publications	38

LIST OF FIGURES

Figure 1: External Features	5
Figure 2: Terminal Compartment Features	5
Figure 3: Lifting the Transformer	11
Figure 4: Dual Voltage Switch	17
Figure 5: Bay-O-Net Expulsion Fuse and Holder with Isolation Link ..	20
Figure 6: Bay-O-Net Current Limiting Full Range Fuse and Holder ...	20
Figure 7: Load-Break Drawout Fuseholders	21
Figure 8: Dead-Break Drawout Fuseholders	21
Figure 9: Arc Strangler	22
Figure 10: Fused Arc-Strangler	22
Figure 11: Arc-Strangler with Clip Fuse	22
Figure 12: Expulsion Type Fuse	23
Figure 13: Instantaneous Trip Setting	25

LIST OF TABLES

Table 1: Torque Guidelines	15
Table 2: QED-3 Circuit Breaker Connector Bolts	15
Table 3: Liquid Level Gauge.....	24
Table 4: Blank Fillers and Extensions.....	28
Table 5: Installation Instructions	38
Table 6: Instruction and Maintenance Bulletins	39
Table 7: Ground Fault Field Test Instructions.....	39
Table 8: Distribution Reference Catalogs	39
Table 9: Other Reference Literature	39

SECTION 1—STANDARD FEATURES

Figure 1: External Features



The pad mounted transformer differs from the substation or pole-style transformer by its applications and external appearance. Designed for application with underground feeders, the pad mounted transformer is tamper resistant and compartmentalized on the front.

Figure 2: Terminal Compartment Features

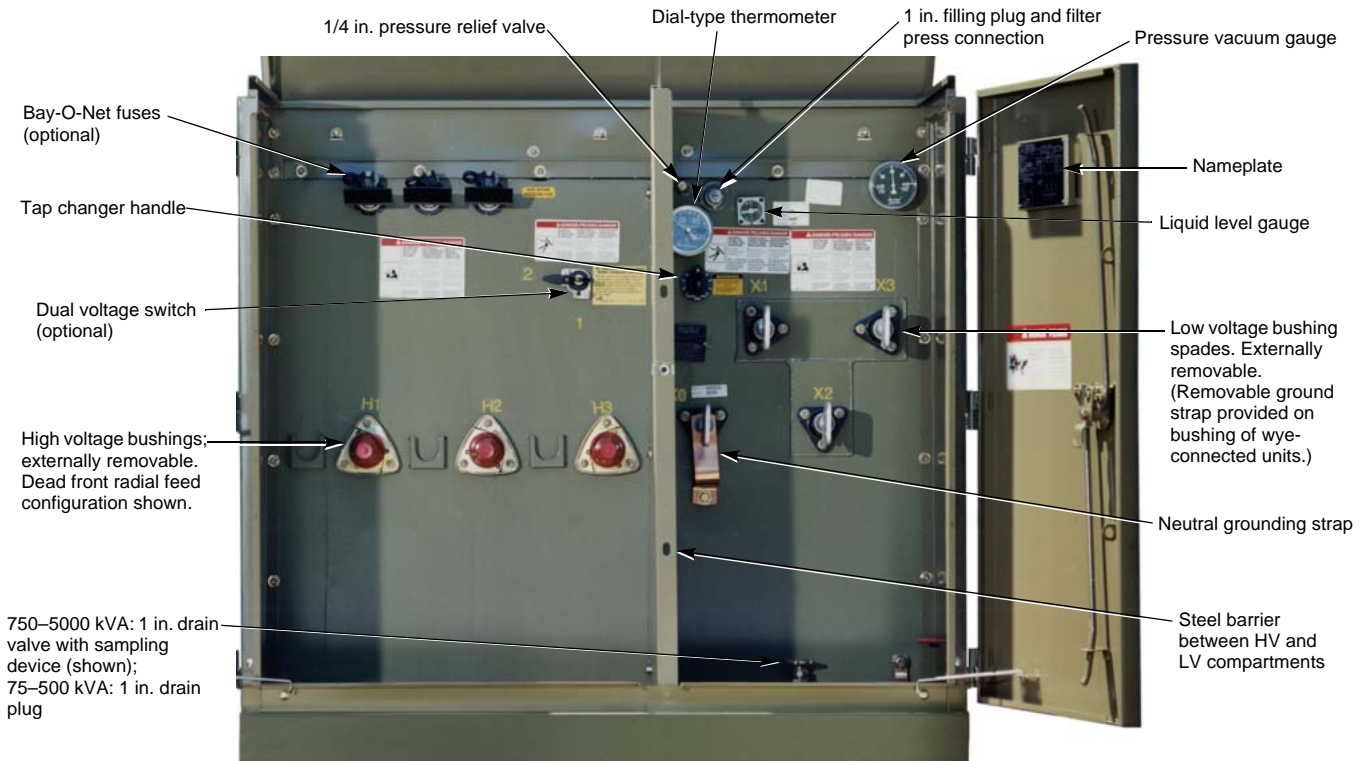

SECTION 2—INTRODUCTION

This instruction bulletin details information about installing, operating, and maintaining liquid filled, compartmental type, pad mounted transformers. Each transformer has its own specification and unique construction features. These features are detailed in the transformer outline and nameplate drawings.

This instruction bulletin is not an application guide for the transformer or a substitute for adequate training in safe working procedures for this and related electrical equipment. Installation of this electrical equipment may require special licenses or training. Consult applicable national, industry, and local codes for specific requirements.

The successful operation of any transformer depends on various factors such as installation, loading, service conditions, and maintenance. Electrical systems in which transformers, along with vacuum or SF⁶ circuit breakers, are used are capable of high frequency overvoltages which will not be suppressed by lightning arrestors. These medium voltage systems may require a detailed, high frequency overvoltage system analysis and/or the addition of high frequency overvoltage protection. The transformer should be installed in conditions as specified in ANSI/IEEE Section C57.12.00 *Usual Service Conditions*, unless the transformer is designed specifically for operation in conditions other than the usual service conditions.

NOTE: If additional information is needed that is not covered by this instruction bulletin, contact the nearest Schneider Electric field sales representative, or Square D Services at 1-800-634-2003.

SECTION 3— SAFETY PRECAUTIONS

⚠ DANGER

HAZARD OF ELECTRIC SHOCK, EXPLOSION, OR ARC FLASH

- Apply appropriate personal protective equipment (PPE) and follow safe electrical work practices. See NFPA 70E.
- Read and understand this entire instruction bulletin before installing, operating, or maintaining a liquid filled transformer. Follow all applicable local and national codes.
- Disconnect all power and verify the transformer is de-energized before servicing the transformer. Operation of a primary protective device may be evidence of a faulted transformer. Do not re-energize the transformer until the cause of operation of the primary protective device is found and corrected.
- Many parts of the transformer operate at high voltages. **DO NOT TOUCH.** Use only electrically insulated tools and clothing, and protective gear when working around electrical equipment.
- Do not rely on visual indications such as switch position or fuse removal for determining a de-energized condition. Always assume that a terminal is energized unless it is checked with a properly rated meter to ensure the terminal is de-energized and grounded.
- Before servicing the transformer, ensure all static charge has been discharged by grounding the coils with an appropriate grounding device.
- This equipment must only be installed and serviced by qualified electrical personnel.
- Turn off all power supplying this equipment before working on or inside equipment.
- Always use a properly rated voltage sensing device to confirm power is off.
- Replace all devices, doors, and covers before turning on power to this equipment.

Failure to follow these instructions will result in death or serious injury.

Do not remove, paint over, or cover the warning labels and nameplates on the transformer.

SECTION 4—RECEIVING, HANDLING, AND STORAGE

Receiving

Initial Inspection

This transformer has been furnished with a pentahead locking bolt that must be loosened to open the compartment. This bolt can be turned with a standard pentahead socket wrench, as used widely in the utility industry. Sockets can be obtained from the Snap-On Company (tool #B2191) or from other tool distributors.

Before unloading the transformer, follow steps 1–3:

1. Verify that the serial number on the transformer nameplate matches the serial number listed on the bill of lading. If the numbers do not match, contact your local Schneider Electric field sales representative immediately.
2. Review the shipping papers to ensure the shipment is complete. Accessories, hardware, or both may arrive in a separate container on a separate pallet. Claims for shortages or errors must be made in writing to Schneider Electric within 60 days after delivery. Failure to give such notice will constitute unqualified acceptance and a waiver of all such claims by the purchaser.

For details concerning claims for equipment shortages and other errors, refer to the Schneider Electric “Terms and Conditions of Sale”.
3. Before unloading the transformer, complete external features checks a–f:
 - a. Check for any obvious dents or scratches in the tank walls or cooling radiator. Such dents and/or scratches in the paint finish can most often be corrected by simple touch-up procedures (see “Exterior Finish” on page 33).
 - b. Check for liquid coolant leaks. Look for oily streaks on the transformer surface, at weld seams, on high or low voltage bushing parts, and any collection of the insulating coolant at the base of the transformer. If found, investigate them thoroughly to determine if a leak does exist on the transformer. A “pinhole” leak or any bushing leak resulting in a very slow loss of liquid is field repairable. Refer to pages 33–34 for information on repairing leaks.
 - c. Check for broken, cracked, or damaged bushings.
 - d. Check for missing or damaged parts, or packaging which shipped separately from the transformer.
 - e. Check the nameplate for design compliance. Voltage, kVA ratings, percentage impedance voltage (%IZ), and other design features must comply with the job specification and outline drawing.
 - f. Check for accessory features by reviewing shipping papers, outline and wiring drawings, instruction bulletins, and other pertinent documents that are supplied with the transformer. The transformer outline drawing for the specific order indicates which accessories should be present and their location on the unit.

Internal Inspection

The objective of the internal inspection is to locate any damage which might have occurred in shipment. **In most cases, an inspection of the internal tank is rarely necessary and is required only if there is obvious indication the tank has sustained severe impact damage in transit. Do not perform an internal inspection unless authorized by Schneider Electric.** Pay particular attention to leads, bolted mechanical and electrical joints, tap changers, current transformers, cores, and insulation structure. If removing the maintenance hand hole cover is necessary, refer to “Opening the Transformer Tank” on page 36.

The tank has been sealed at the factory to eliminate any possibility of contamination of the liquid coolant by moisture. The accumulation of moisture over time can destroy the insulating properties of the liquid coolant. Therefore, if the transformer is opened for internal inspection, do not leave it open for longer than two hours. Initial inspection of the pressure seal is necessary and can be accomplished by either of the following methods. Consult your local Schneider Electric field sales representative before performing any repairs.

1. Observe the pressure/vacuum gauge. A consistent rise and fall in pressure readings with the rise and fall of liquid coolant and ambient temperature demonstrates an effective seal. A flat or unchanged reading over time and at varying temperatures is evidence of a leak that must be located and repaired. Refer to “Locating Pressure Leaks Above the Liquid Level” on page 33.
2. Pull the pressure relief valve ring momentarily, or loosen the vent plug. The sound of rushing air is an indication the unit has maintained an effective seal. If there is no sound of rushing air, the seal may still be effective, as this may only be an indication that the ambient temperature has decreased sufficiently to lower the pressure to zero. If this is the case, repeat this test at a time of day when the temperature is significantly different. If it is apparent the internal pressure is remaining unchanged following this procedure, review “Maintenance of Internal Features” on page 34 before locating and repairing any leak.

Liquid Sampling

An initial visual inspection and testing of the liquid insulating coolant is not required unless there is indication that moisture or other contaminants have accidentally entered the tank during transit. If there are indications of moisture in the insulation, contact your Schneider Electric field sales representative immediately for confirmation of the analysis and for recommendations on the drying procedure to be followed. If sampling the liquid coolant is required, see “Sampling the Liquid” on page 34.

▲ WARNING

HAZARD OF ELECTRIC SHOCK, EXPLOSION, OR ARC FLASH

- Do not energize transformer if the liquid level is low.
- Maintain the proper liquid level when the transformer is energized.

Failure to follow these instructions can result in death or serious injury and damage to equipment.

Liquid Level Inspection

The transformer is shipped with the liquid coolant at the correct operation level. Verify this when the transformer is received by reading the level from the level gauge. The indicator should be halfway between the 25° C mark and the “high” or the “low” mark.

If the transformer is shipped without a liquid level gauge, the liquid level should be checked by removing the liquid level plug located at the 25° C mark. Any unit which does not have the proper liquid level should be checked for leaks and refilled through the vent plug before placing it in service. Refill only with the same type of liquid as that specified on the transformer nameplate.

The transformer was filled or processed at the factory with non-polychlorinated biphenyl (PCB) dielectric fluid in accordance with federal PCB regulations 40 CFR 761, et seq. The non-PCB fluid contained less than 1 ppm at time of processing or filling. The owner should take the necessary precautions so that PCB contamination is not introduced during field filling or maintenance of the transformer.

Consult your Schneider Electric field sales representative if the level is not correct.

Handling

The transformer is shipped on an open carrier trailer to facilitate the use of a crane for unloading. Unloading the unit with a forklift is **NOT** recommended since the weights are often excessive and the coolant radiators are easily damaged. The transformer must be handled in the normal upright position to avoid internal stresses on the core and coil mounting assembly and to prevent trapping air in the windings that could create serious problems when the transformer is energized. The transformer weight is shown on the nameplate.

Unloading and Lifting

⚠ DANGER

HAZARD OF FALLING EQUIPMENT AND CRUSHING

- Use a crane to unload the transformer. **DO NOT UNLOAD** using a forklift. The transformer is top heavy and may become unbalanced.
- Keep all unnecessary personnel away while handling and moving the transformer.

Failure to follow these instructions will result in death or serious injury.

Lifting hooks or lugs are provided for lifting the complete transformer. When using a single point hitch (see Figure 3 on page 11), the angle between the cables (when viewed from the front or long side of the transformer) must not exceed 60 degrees. If the cables are at least as long as the longest dimension of the transformer tank, the angle will not exceed the maximum.

NOTE: Do not use the holes in the lifting hook on the transformer (if provided) for lifting.

Figure 3: Lifting the Transformer

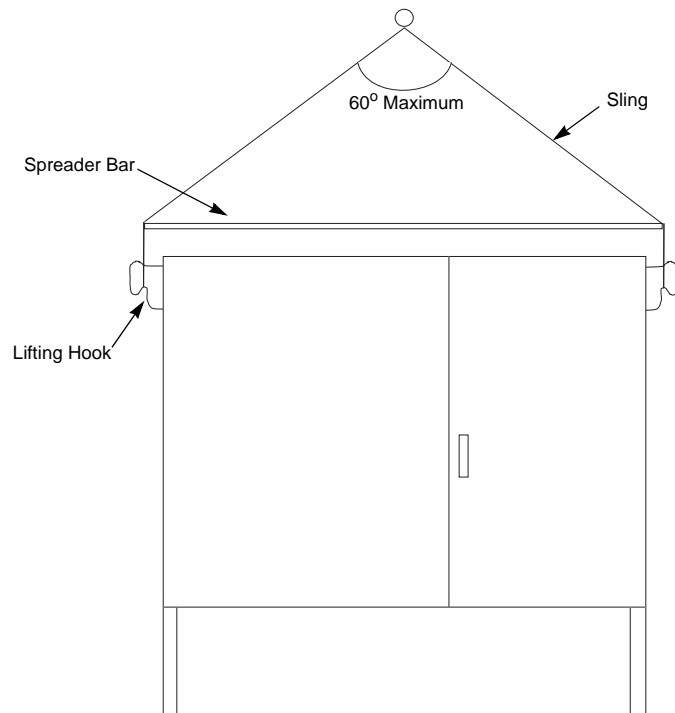

Jacking may be accomplished at the corners of the tank base plate. Do not attempt to raise the transformer by placing jacks under drain valves, pipe connections, or other attachments. When jacking, use all of the jacking pads. Never attempt to lift the transformer by using cranes or jacks on any part of the transformer other than the fittings provided for this purpose.

When the transformer cannot be handled by a crane, it may be skidded or moved on rollers, but be careful not to damage the tank base structure. When using rollers under large transformers, use skids to distribute the stress over the tank base.

Storing

If the transformer must be stored, it should be stored completely assembled, preferably in its permanent location on the concrete pad. If a level concrete pad is not available, a pallet of adequate strength will keep the unit from direct contact with the ground. Maintain adequate ventilation underneath the transformer. Do not store the transformer in the presence of corrosive gases such as chlorine, acid fumes, etc. Periodically inspect the stored transformer just as a unit that is in service. Ensure that an effective pressure seal is maintained and check for leaks and any rust spots.

Transformers should not be stacked on top of one another. Exercise care to prevent submersion in water.

If a transformer is to be stored more than one year, pressurize the gas space above the liquid with dry nitrogen between 2–3 PSIG. This will prevent moisture from being pulled into the tank by a negative pressure.

SECTION 5—INSTALLATION

NOTE: Complete start-up services are available from Square D Services. They can provide assistance in a variety of areas, from installation to comprehensive testing and verification of the new equipment. Contact Square D Services at 1-800-634-2003, 24-hours a day.

Shipping braces may be used to secure the unit while it is transported. There are two kinds: those that do not interfere with the operation of the transformer and need not be removed, and those that must be removed for electrical clearances or other reasons. Always check the notes on the outline drawings for instructions on shipping braces that must be removed.

Transformer Location

Follow all local and national codes when locating the transformer. Make sure the radiators are clear of obstructions. The transformer must be at least 24 inches (710 mm) from walls or other obstructions to allow circulation of air around each unit.

For indoor installations, consult local and national codes to ensure all applicable requirements are satisfied. If the transformer is located near combustible materials, make sure the transformer meets or exceeds the minimum clearances as required by the National Electrical Code® (NEC) or other applicable local codes.

Place transformer on a foundation of sufficient strength to support the weight of the transformer, preferably of reinforced concrete. The transformer cabinet should sit flush on the pad, allowing no gaps which would compromise the tamper resistance of the transformer. Do not place the transformer directly on an earthen surface. Ensure the foundation has adequate drainage. Seismic regulations may require that the transformer be anchored to the pad. When supplied, hold-down cleats or brackets should be used to bolt the transformer securely to the pad.

The unit should not be tilted in any direction greater than 1.5°, as a greater tilt will cause deviations in liquid level near fuses, pressure relief devices, or other accessories specifically located at or near the 25° C liquid level.

At altitudes above 3300 ft. (1006 m), the decreased air density reduces the transformer cooling efficiency and bushing BIL rating. Contact your local Schneider Electric field sales representative to verify the suitability of the unit for application at higher altitudes.

Restricting Access to the Transformer

Compartmental-type pad mounted transformers are designed and constructed to be tamper-resistant and therefore need not be located in a restricted area. However, if for any reason modifications are made to the transformer or compartment that compromise the tamper-resistant construction, the transformer must then be located in a restricted area. Modifications of this type may void the warranty. Consult your local Schneider Electric field sales representative before making any modifications to the transformer.

⚠ DANGER

HAZARD OF ELECTRIC SHOCK, EXPLOSION, OR ARC FLASH

Do not make modifications to the transformer or compartment that will result in compromising the tamper-resistant construction.

Failure to follow this instruction will result in death or serious injury.

Grounding

⚠ DANGER

HAZARD OF ELECTRIC SHOCK, EXPLOSION, OR ARC FLASH

Follow all applicable codes for grounding all equipment. Ensure proper grounding. Improper grounding can cause high voltage on the transformer tank and secondary terminals.

Failure to follow this instruction will result in death or serious injury.

Ground the transformer tank at all times. To ground the tank permanently, use ground pads or nuts at the base of the tank wall in both the high- and low-voltage compartments. A good permanent, low-resistance ground is essential for adequate protection from the tank becoming momentarily energized by internal or external faults or lightning surges. Do not use cubicle hold-down bolts, cleats, or any other plug fitting to establish a tank ground.

Conduit Area

1. Locate and terminate all conduit in the transformer enclosure in the “available conduit area” designated on the equipment drawing.
2. Install the conduit properly. Use hubs and ring connectors to protect the cables.

NOTE: If top entry (such as bus duct), do not use the top of the compartment to support the weight of the conduit or bus duct. Support the conduit or bus duct independently.

Under seismic conditions, the top of the compartment can move as much as 3 inches (76 mm) in any direction. Any top incoming cables must accommodate this motion.

3. Bond all conduit, stubs, and ring connectors to the transformer ground with approved electrical connections.

Cable Pulling

1. Use only cable sizes suitable for a proper fit with the corresponding lugs.
2. Pull the proper number of line-side and load-side cables according to the load served and the NEC.
3. Position the cables inside the compartment so that they are not subject to physical damage.
4. Maintain the maximum possible bending radii and proper clearance to grounded parts. If any cables are lying or bearing on structural members, support them to relieve this condition or place suitable protective material at the bearing point to protect the cable insulation.

Cable Terminations Using Unshielded Cable

1. Strip a length of insulation from the end of the cable sufficient to fit into the full length of the lug barrel, being careful not to nick or ring the strands. Use a proper insulation stripping tool.
2. Thoroughly clean aluminum cable contact surfaces with a wire brush or scrub them with an abrasive cloth to remove oxides and foreign matter.
3. Immediately apply an acceptable joint compound to the bare aluminum surfaces.

4. If compression-type lugs are furnished on any switch or circuit breaker, or as the main incoming power lugs, unbolt and remove them to create sufficient room for crimping the lugs to the cables with the crimping tool.
 - a. Insert the cable into the lug barrel and, using the crimping tool, make the specified number of crimps per the manufacturer's recommendations.
 - b. Wipe excess joint compound from the connector and insulation.
 - c. With the cables connected, remount the lugs onto the bushings, switches, or circuit breakers. Torque the bolts to the values given in "Electrical Connections" below.
5. Set screw-type lugs are standard on molded case circuit breakers. Torque these lugs to, **but do not exceed**, the specified values. Torque values for circuit breaker and switch lugs are marked on these units.

Cable Terminations Using Shielded Cable

For live front transformers, install properly rated cable stress relief terminator kits on each cable. Follow the instructions provided with the stress relief terminator kit. Install the terminator so the top of the terminator (live part) is at approximately the same height as the top of the lightning arrestors, if provided.

For dead front transformers, use properly rated elbow terminators sized to fit the high voltage bushings. Follow the installation instructions provided with the elbow terminators.

Electrical Connections

All mating joints of electrical connections must be clean and properly tightened. Ensure that there are no strains on the terminals that could cause loose connections. See Table 1 and Table 2 on page 15 for the recommended torque values.

Make external electrical connections in such a way as not to exceed a cantilever load of 100 lb (45 kg) on the bushings. Greater loads may cause bushing damage. Inspect the bushing periodically for broken or cracked porcelain and faulty gaskets.

Table 1: Torque Guidelines

Bolt Size	General Torque Values		
	Grade 2 Plated lb-ft (N•m)	18-8 Stainless Steel lb-ft (N•m)	Silicon Bronze lb-ft (N•m)
1/4-20	4–6 (5–8)	4–6 (5–8)	4–6 (5–8)
5/16-18	6–12 (8–16)	6–12 (8–16)	6–12 (8–16)
3/8-16	15–20 (20–27)	15–20 (20–27)	15–20 (20–27)
1/2-13	25–30 (34–41)	25–30 (34–41)	—

Table 2: QED-3 Circuit Breaker Connector Bolts

Circuit Breaker Type	Torque Value Line/Load Connector Bolts lb-in (N•m)
FA, FH, FC, FI	55–65 (6–7)
KA, KH, KC, KI	65–75 (7–8)
LA, LH	145–160 (16–18)
MA, MH, MX, ME	130–150 (15–17)
NA, NC, NX, NE	130–150 (15–17)

High Voltage Bushing Connections

High voltage bushings are provided according to the job specification as either porcelain live-front with exposed metal eyebolt terminals or as a molded dead-front. Lugs are not required to terminate the cable on a live front bushing. However, with the live front design and the use of shielded cable, a cable stress relief terminator kit must be installed on each high voltage cable. An elbow terminator kit must be installed on the cable to permit connection to the dead front bushing. On the dead front design, the elbow terminator kit includes the necessary cable stress relief. Contact your local Schneider Electric field sales representative for application or order information on the live front or dead front terminator kits. Installation instructions are provided with the terminator kits.

⚠ WARNING
HAZARD OF ELECTRIC SHOCK, EXPLOSION, OR ARC FLASH
Unused dead front bushings that are energized must be properly terminated with a grounding cap.
Failure to follow this instruction can result in death or serious injury and damage to equipment.

The one-piece integrated bushing is shipped with a plastic protective cap that should be left in place until the transformer is energized to avoid dirt or moisture contaminating the internal bushing contact points. On an energized transformer, a ground cap must be plugged onto any unused bushing well or insert to avoid partial discharge and subsequent bushing damage.

The transformer nameplate illustrates the internal wiring and external marking of each bushing. Refer to the nameplate on the transformer for clarity on where to connect each incoming cable.

On live front designs, ensure adequate air clearances between all live parts.

Low Voltage Bushing Connections

Low voltage bushings through 600 volts are supplied with NEMA standard hole drillings and spacings but are not supplied with lugs. Lugs may be stacked or mounted on either face of the spade. A minimum 1 in. (25.4 mm) air clearance must be maintained between live parts, phase-to-phase and phase to ground for 600 volts or less.

Low voltage terminations are high current carrying devices. All bolted or crimped points should be checked prior to energizing the unit to ensure the joints are tight. When threaded terminators are attached to the threaded secondary stud, install a backup nut on the threaded secondary stud and back it up tightly against the threaded terminator to ensure maximum contact and to minimize joint resistance and reduce the possibility of overheating.

SECTION 6—OPERATION

⚠ DANGER

HAZARD OF ELECTRIC SHOCK, EXPLOSION, OR ARC FLASH

De-energize the transformer before operating the tap changer.

Failure to follow this instruction will result in death or serious injury and damage to equipment.

Tap Changer

The no-load, de-energized tap changer is provided to adjust the output voltage to its rated voltage. Do not use it to raise or lower the output (secondary) voltage to any voltage other than the rating appearing on the nameplate. If the tap changer is used to set the voltage different from the rated voltage, it will result in a high noise level, higher core loss, and possible core saturation.

The no-load tap changer is provided with an operating handle, tap position indicator, and provision for padlocking. Some no-load tap changers may have provisions for a Kirk Key, or equivalent, interlock system.

Before energizing or applying voltage to the transformer, turn the tap changer to the desired voltage position. Positions are marked 1, 2, 3, 4, and 5 (or A, B, C, D, and E), and correspond to the primary voltages stamped on the transformer nameplate. The unit is shipped with the tap switch in the rated voltage position, normally position 3 (or C). Each position changes the primary-to-secondary winding ratio by 2.5% and can alter the secondary voltage by this increment. Tap positions of 2.5% are typical but not the rule. Other percentages are supplied as required.

To raise the secondary voltage, move the tap switch to position 4 (or D) or 5 (or E). To lower the secondary voltage, move the tap switch to position 1 (or A) or 2 (or B).

To change the voltage position, perform the following steps:

1. Make sure the transformer is de-energized.
2. Back out the locking screw until it is clear of the locking hole.
3. Turn the operating handle to the desired tap position.
4. Re-tighten the locking screw to minimize the possibility of unintentional movement.

Some large-size units are furnished with a power-transformer tap changer drive which requires pulling of a locking pin and a full turn of the handle for each change in tap position.

Dual Voltage or Delta/Wye Switch Operation

⚠ DANGER

HAZARD OF ELECTRIC SHOCK, EXPLOSION, OR ARC FLASH

De-energize the transformer before operating the dual voltage or delta/wye switch.

Failure to follow this instruction will result in death or serious injury and damage to equipment.

⚠ WARNING

HAZARD OF ELECTRIC SHOCK, EXPLOSION, OR ARC FLASH

When changing the dual voltage switch, replace fuses with those of the proper rating before energizing the transformer.

Failure to follow this instruction can result in death or serious injury and damage to equipment.

Transformers designed with dual voltage windings or reconnectable delta/wye windings as indicated on the nameplate have a de-energized, two-position, dual voltage or delta/wye switch. The voltage source must be disconnected before operating the hand-operated switch. If the voltage source is not disconnected before the switch is operated, the transformer will be permanently damaged.

Figure 4: Dual Voltage Switch

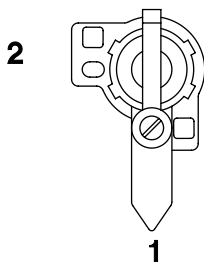

On a dual voltage switch (see Figure 4), position 1 is the low (or multiple connected) position, while position 2 is the high (or series connected) position. To change the voltage position, perform the following steps:

1. Make sure the transformer is de-energized.
2. Back out the locking screw until it is clear of the locking hole.
3. Pull out the handle until it will rotate.
4. Turn the operating handle to the new position.
5. Release the handle.
6. Re-tighten the locking screw to minimize the possibility of unintentional movement.

Parking Stands

Parking stands, or brackets, are provided with dead-front bushings, and are located next to the bushings. These brackets provide a storage location for parking bushings, to be used for storage of disengaged elbow terminators.

⚠ WARNING

HAZARD OF ELECTRIC SHOCK, EXPLOSION, OR ARC FLASH

Unused dead front bushings that are energized must be properly terminated with a grounding cap.

Failure to follow this instruction can result in death or serious injury and damage to equipment.

Live-Line Tools (Hot Sticks)

⚠ DANGER

HAZARDOUS VOLTAGE. HAZARD OF ELECTRIC SHOCK, EXPLOSION, OR ARC FLASH

- Do not attempt to operate by hand any device that is designed to be operated by a live-line tool.
- Do not use any live-line tools that have not been inspected and tested in accordance with OSHA 1910.269(j).

Failure to follow these instructions will result in death or serious injury

Some devices such as load-break under-liquid switches, Bay-O-Net fuses, dry well canister fuses, and dead front elbow terminators are designed to be operated with live-line tools such as “shot-gun sticks” or “hot sticks”. Before using any live-line tool, it must be wiped clean, and inspected and tested per OSHA 1910.269(j).

Follow the instructions of the live-line tool manufacturer for proper operation. Do not attempt to operate by hand any device that is designed to be operated with a live-line tool.

Load Break Switch Operation

If provided, a spring-loaded, gang-operated, load-break under-liquid switch is located in the high voltage compartment. This switch is either a two-position (ON-OFF) switch or a three- or four-position switch and is operated with a live-line tool (hot stick). The switch positions are marked on the tank front plate and shown on the transformer nameplate.

The two-position switch is operated by inserting the hot stick into the operating handle and rotating the switch to either the ON or OFF position.

CAUTION

RISK OF EQUIPMENT DAMAGE

Do not stop and reverse direction of the switch until it has changed position.

Failure to follow this instruction will result in equipment damage.

The three- or four-position switch is operated by inserting the hot stick in the index plate and moving the plate over the peg between its present setting and the next setting. The index plate prevents the switch from switching more than 90°, or one position at a time. Next, insert the hot stick into the handle of the switch and turn it approximately 180° until the switch snaps into the next position. (Do not stop and reverse direction of the switch until it has changed position, as this will damage the switch mechanism.) Repeat this procedure until the switch is in the desired position.

Fuses

⚠ DANGER

HAZARD OF ELECTRIC SHOCK, EXPLOSION, OR ARC FLASH

- Completely de-energize the transformer before replacing fuses.
- Do not energize or de-energize the transformer with single phase switches or fuses.
- Use only ganged three phase switches to energize or de-energize the transformer.
- Do not operate the transformer with any phases open.
- Only qualified personnel with appropriate measurement devices should measure the voltages on the transformer.

Failure to follow these instructions will result in death, personal injury, or damage to the equipment.

⚠ WARNING

RISK OF ELECTRIC SHOCK, EXPLOSION, OR ARC FLASH

Operation of a fuse may indicate a faulted transformer. Do not replace the fuse unless the cause of the fuse operation has been positively identified and corrected.

Failure to follow this instruction can result in death or serious injury and damage to equipment.

Operation of a fuse may indicate a faulted transformer. Do not replace the fuse unless the cause of the fuse operation has been positively identified and corrected. If the cause of the fuse operation cannot be positively identified, contact Schneider Electric before testing or energizing the transformer.

Fuses should be operated within their ratings. Replacement fuses must have the equivalent voltage and time-current characteristics of the original fuses.

Bay-O-Net Fuse Operation

The Bay-O-Net fuse is a dead-front, individual-phase disconnect device that is load-break rated and operated by a live-line tool (hot stick). This type of fuse is located in the high voltage compartment above the primary bushings. The Bay-O-Net fuse can be either an expulsion type or a full range current-limiting type fuse (Figures 5 and 6). Before energizing, ensure the Bay-O-Net fuse is properly latched into place.

Figure 5: Bay-O-Net Expulsion Fuse and Holder with Isolation Link

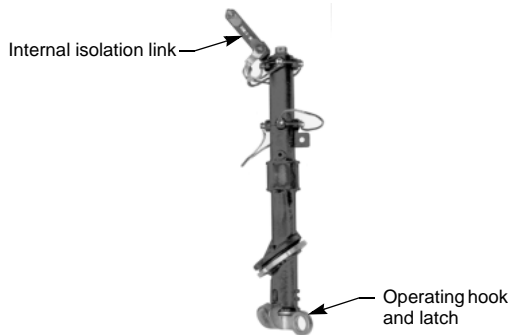
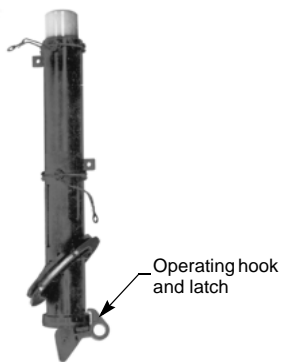

Figure 6: Bay-O-Net Current Limiting Full Range Fuse and Holder



⚠ DANGER

HAZARD OF FUSE AND LIQUID EXPULSION

Release built-up air pressure in the tank before removing the fuse.

Failure to follow this instruction will result in death or serious injury.

To operate the Bay-O-Net Loadbreak Fuseholders, on some models you must first raise the hinged, flip-top weather cover.

1. With both cabinet doors fully open (over 90°), push upward on the front edge of the cover assembly.
2. Tilt the hinged cover backward until the supporting arm (connected to the high-low barrier) can be securely latched in place on the inside of the cover.

With the cover in place, proceed with the operating instructions for the Bay-O-Net Loadbreak Fuseholder.

Remove Fuseholder

1. Vent the transformer by operating the pressure relief valve. See “Pressure Relief Valve” on page 24.
2. Attach a live-line tool to the handle eye.
3. Stand to one side and unlock the handle.
4. Push down and rotate the handle 90° clockwise in the housing to break any adhesion between the gasket and the housing.
5. Firmly pull the fuseholder out approximately 6 in. to open the circuit. Wait a few seconds while the liquid drains back into the tank, then completely withdraw the fuseholder.

Replace Fuse

Replace the fuse by following the fuse manufacturer's instructions that are shipped with the fuse.

Reinstall Fuseholder

1. Attach a live-line tool to the handle eye.
2. Stand to one side and place the end of the fuseholder just inside the housing.
3. Quickly push the fuseholder in until the dust cap seats against the housing.
4. Push down and rotate the locking handle, hooking it over the shoulder of the housing.

When the Bay-O-Net operations are complete, close the hinged weather cover, when provided, as follows:

1. Release the latch on the hinged weather cover by tilting the cover slightly backwards.
2. Lower the cover, making sure it is all the way down. (The upper high-voltage door bolt should engage through the hole in the hinged weather cover.)

⚠ DANGER

HAZARD OF ELECTRIC SHOCK, EXPLOSION, OR ARC FLASH

Operation of a primary protective device may be evidence of a faulted transformer. Do not re-energize the unit if there is any indication of a failure.

Failure to follow this instruction will result in death or serious injury.

Dry Well Canister Fuse Operation

The dry well canister is a fluid-tight, current-limiting fuse holder that extends under fluid into the tank above the high voltage bushings.

The canister fuse normally supplied is a non-load-break-and-make, individually-phased fuse device. If required, the dry well canister is supplied in conjunction with a mechanical interlock to a load-break switch (see "Load Break Switch Operation" on page 18) that prevents removal of the fuse unless the switch is in the "OFF" or de-energized position. When required, a load break-and-make rated canister is supplied (not available on all kVA sizes.)

Load-Break Fuse Operation

To operate or change fuses in load-break fuseholders, follow these instructions:

Figure 7: Load-Break Drawout Fuseholders

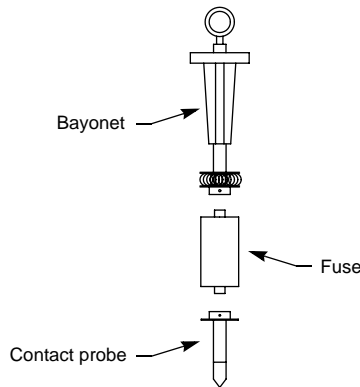

Load Break

1. Attach a live-line tool to the hook eye.
2. Quickly pull the fuseholder assembly completely from the housing.

Replace Fuse

1. Unscrew the fuse from the insulating bayonet and contact probe.
2. Replace with new fuse of equivalent rating and characteristics.
3. Tightly screw the new fuse onto the insulating bayonet and contact probe.

Load Make

1. Attach a live-line tool to the hook eye.
2. Insert the end of the fuseholder until the contact spring has just entered the housing.
3. Quickly push the fuseholder assembly straight into the housing in until the dust cap seats against the housing and grounding clip.

Non-Load-Break Fuse Operation

To operate or change fuses in non-load-break (dead-break) fuseholders, follow these instructions:

Figure 8: Dead-Break Drawout Fuseholders

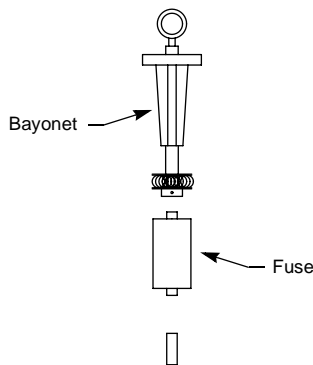

Remove Fuseholder

1. Attach a live-line tool to the hook eye.
2. Pull the fuseholder straight out from the housing.

Replace Fuse

1. Unscrew the fuse from the insulating bayonet.
2. Replace with new fuse of equivalent rating and characteristics.
3. Tightly screw the new fuse onto the insulating bayonet.

Reinstall Fuseholder

1. Attach a live-line tool to the hook eye.
2. Insert the fuseholder into the housing.
3. Push the fuseholder in firmly until the dust cap seats against the housing and grounding clip.

Internal Partial Range Current-Limiting Fuse

The internal partial range current-limiting fuse is used in series with a low current interrupting device, such as a protective link or bayonet.

The partial range fuse is designed to clear low impedance (high current) faults, with the expulsion fuse clearing any high impedance faults or overloads. When properly applied, the partial range fuse will only operate for internal transformer faults. Upon operation of a partial range fuse, Schneider Electric recommends removing the unit from service and returning it to Schneider Electric for repair.

Arc-Strangler Switch Operation

The Arc-Strangler is a 200 A load-break rated, individual-phase switch device, operated with a live-line tool (hot stick). The Arc-Strangler may incorporate a full range, current-limiting fuse on the switch blade or, depending on design, may be tandem-mounted with a clip-style, current-limiting fuse (see Figures 9, 10, and 11).

Figure 9: Arc Strangler



Figure 10: Fused Arc-Strangler



Figure 11: Arc-Strangler with Clip Fuse

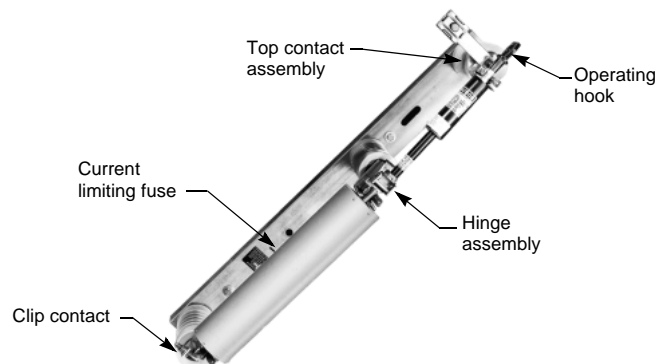

To operate the switch, insert the hot stick in the operating hook and pull forward. The Arc-Strangler should swing open. To remove the Arc-Strangler, insert the hot stick in the hinge opening and lift up.

The top and hinge contact assemblies must be rigidly fastened to the insulators to prevent rotation and misalignment of the contacts. The contact spacings are set at the factory and normally do not require adjustment. If contact adjustment is ever required, consult your local Schneider Electric field sales representative.

Weak Link Fuses

When supplied, weak-link expulsion-type cartridge fuses are factory installed under fluid on a terminal block at the top of the internal core and coil assembly (see Figure 12). To replace these fuse elements, remove the tank hand hole cover. See “Opening the Transformer Tank” on page 36.

Figure 12: Expulsion Type Fuse



S & C Fused Switch

When an S & C fused switch is provided, follow the manufacturer's instructions for operating this equipment. Use only S & C tools to operate these switches. Schneider Electric does not recommend using S & C switches to energize or de-energize the transformer.

Accessories

Accessories supplied with the transformer are shown on the outline drawing. When accessories have control wiring or are equipped with alarm contacts, refer to the control wiring diagram or outline drawing for contact type, ratings, and terminal points.

Dial Thermometer

The liquid temperature indicator is a dial-type precision instrument with an indicator pointer coupled to a bi-metallic element. The bi-metallic element fits into a sealed dry well located under the liquid level. This device can be easily installed or removed from the dry well without exposing the transformer liquid. See Figure 2 on page 5 for the location of the dial thermometer.

NOTE: Do not fill the well with liquid before inserting the stem of the thermometer as this may damage the thermometer. Do not tighten the thermometer in the well any more than necessary to place the dial in an upright position.

The dial is calibrated in degrees centigrade and has a red maximum indicating pointer that indicates the maximum temperature reached since the last reset. To reset the indicator pointer, turn the middle knob on the dial face or, on some models, push the Reset button.

Temperature limits for any specific condition of loading should be in accordance with ANSI C57.91, Guide for Loading Mineral-Oil Immersed Transformers. To ensure normal transformer life, the average temperature for any 24-hour period must not exceed 95 °C.

If specified, switch contacts are supplied inside the dial thermometer and brought out through control wires at the bottom of the dial. A variety of contact arrangements are available. Consult your Schneider Electric field sales representative for a specific application.

Liquid Level Gauge

The liquid level gauge is a precision dial-type instrument with the indicating pointer magnetically coupled to an internal float arm. The level gauge is located at the normal 25 °C fill line (see Figure 2 on page 5). The complete device, including the gauge and float arm, can be installed or removed in the field, although removing the tank cover or hand hole may be necessary.

The liquid level rises and falls around the 25 °C level mark depending on the ambient temperature and the transformer loading conditions. Use Table 3 to determine the variation above or below the normal level before adjusting the fluid level. The indicator comes mounted on the transformer tank and requires no maintenance other than the periodic inspection recommended in “Section 8—Maintenance” on page 30.

Table 3: Liquid Level Gauge

Average Liquid Temperature (°C)	Correct Level (percent of scale above or below 25° C level)
85 (high)	100
70	75
55	50
40	25
25 (normal)	0
10	-33
-5	-67
-20 (low)	-100

Contact your Schneider Electric field sales representative if the liquid level gauge does not agree the readings shown in Table 3. On an energized transformer, a liquid level reading of LOW is unacceptable, since a dangerous flashover condition on internal parts may result. Refer to “Draining and Filling the Tank” on page 35 for information on filling the transformer with liquid coolant.

If specified, switch contacts are supplied inside the level gauge housing with control wires brought out at the bottom of the gauge. The controls will operate if the liquid level drops to the LOW setting or below. Contact your Schneider Electric field sales representative for a specific application.

Pressure Vacuum Gauge

The pressure vacuum gauge is a dial-type precision instrument calibrated in pounds per square inch and has a dial reading of ±10 psi maximum. The gauge is located near the top of the transformer above the liquid level (see Figure 2 on page 5). It is easily installed or replaced by tightening or loosening the gauge from its pipe fitting support.

The internal air pressure varies with liquid level and ambient conditions. Pressure readings between ±5 psi are considered normal as long as there is some variation of readings between changing liquid levels. A flat or unchanging pressure reading indicates a defective gauge or a pressure leak. A pressure leak must be corrected to avoid “breathing” of external moist air.

Over a period of time, this condition can destroy the dielectric strength or insulating properties of the liquid coolant. Refer to “Locating Pressure Leaks Above the Liquid Level” on page 33 for information on locating and correcting a pressure leak. Pressure in excess of ±5 psi can be lowered by releasing the pressure relief valve.

Pressure Relief Valve

The pressure relief valve is located near the top above the liquid level (see Figure 2 on page 5). The device is threaded into the tank wall for easy installation or removal. The valve automatically opens when the internal gas pressure increases by 9–11 psi. Once the pressure is relieved, the device

Drain Valve With Sampler

automatically reseals. To manually relieve internal pressure, apply a hook stick to the valve pull ring and gently pull.

A one- or two-inch drain valve and drain plug with a side-mounted 3/8 in. sampler fitting is located at the bottom of the tank wall (see Figure 2 on page 5). Replacement or addition of this valve to a tank filled with liquid is possible, although not recommended. Consult your Schneider Electric field sales representative for this procedure. See “Sampling the Liquid” on page 34 and “Draining and Filling the Tank” on page 35 for the liquid sampling and draining procedure.

Surge Arrestors

Surge arrestors intercept and divert to ground various overvoltage transients (such as lightning surges) which occur on the distribution system. On transformers with surge arrestors, the arrestors must be disconnected whenever high potential or induced potential tests are made.

NOTE: Surge arrestors will not operate for high frequency overvoltages.

Current Transformers

⚠ DANGER

HAZARD OF ELECTRIC SHOCK, EXPLOSION, OR ARC FLASH

Current transformer secondaries must be connected to a load or short-circuited before the transformer is energized to avoid hazardous voltage at the terminals.

Failure to follow this instruction will result in death or serious injury and equipment damage.

If current transformers are provided, their secondary leads are wired to terminal blocks in the low voltage compartment. Refer to the transformer wiring diagram to identify the location of current transformer secondary leads. Current transformer leads are shorted and grounded for transformer shipment. If the current transformers are not connected to a load, they must remain shorted and grounded to avoid hazardous voltage at the secondary terminations.

Molded Case Circuit Breakers

Factory-installed molded case circuit breakers, 250 A frames or larger, have an adjustable magnetic trip, which is shipped on the “LO” setting. The markings between “LO” and “HI” settings represent a range of instantaneous magnetic trip values of 5–10 times the circuit breaker’s continuous current rating. To provide coordinated operation during a fault, adjust the magnetic trip as outlined in the respective instruction manual. All poles are adjusted simultaneously, using a screwdriver, by the single setting (see Figure 13).

Figure 13: Instantaneous Trip Setting

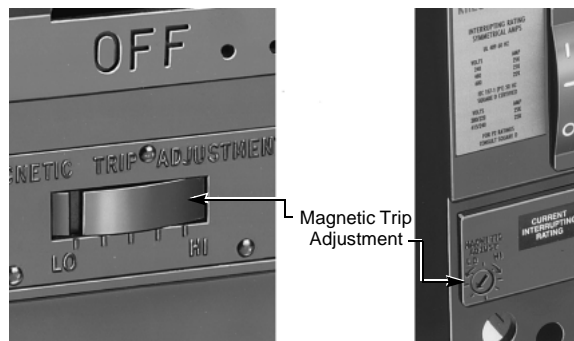

SECTION 7—START-UP TESTING

NOTE: Complete start-up services are available from Square D Services. They can provide assistance in a variety of areas, from installation to comprehensive testing and verification of the new equipment. Contact Square D Services at 1-800-634-2003, 24-hours a day.

⚠ DANGER

HAZARD OF ELECTRIC SHOCK, EXPLOSION, OR ARC FLASH

- Only qualified personnel should perform these tests.
- Disconnect ALL high voltage, low voltage, and neutral connections.
- Disconnect auxiliary equipment such as lightning arrestors, the fan and temperature control system, meters, or any other low voltage control system connected to the windings involved in these tests.
- DO NOT disconnect the ground connection to the transformer frame.

Failure to follow these instructions will result in death or serious injury.

Pre-energization Tests

Before energizing the transformer and placing it in service, perform the following tests at the installation site:

- **Insulation Resistance:** Measures the resistance of the insulation between the primary and secondary windings and from each winding to ground.
- **Turns Ratio:** Measures the ratio of the primary to secondary turns to check for possible insulation degradation in the windings.

Wye-Wye Transformers With HOXO Bushing

Transformers with a wye-wye connection and an HOXO bushing have the neutral of the high and low voltage windings connected together inside the tank. Before the insulation resistance or megger test is performed, separate the two neutrals by following steps 1–7:

1. Open the transformer hand hole cover following the procedure in “Opening the Transformer Tank” on page 36.
2. Locate the HO disconnect inside the tank approximately 10 in. (254 mm) below the tank cover. This is approximately 4 in. (102 mm) under the liquid.
3. Remove the nut securing the HO terminal, being careful not to drop it in the tank.
4. Remove the HO lead and bend it away from the connection point and away from any metal parts.
5. Perform the insulation resistance (megger) tests.
6. Replace the HO lead and tighten the nut.
7. Replace the hand hole cover following the procedure in “Closing the Transformer Tank” on page 37.

Insulation Resistance Testing

Measure the resistance of each winding to ground using a megohm meter. Do not apply greater than 2500 Vdc to any winding.

Turns Ratio Test

Perform the turns ratio test at each tap position and for the full winding.

1. Use a Transformer Turns Ratio (TTR) to measure the ratio between the primary and secondary windings. Follow the manufacturer's instructions for the TTR.
2. Compare these measurements to the transformer nameplate voltage ratio. The measurements should be within .5% of the nameplate voltage ratio. Refer to ANSI C57.12.91 for additional information.

NOTE: A High-Potential (Hi-Pot) test is not recommended. If this test is performed, it must be done with a 60 Hz ac voltage at approximately 75% of the factory-applied test. A dc voltage must not be used for this test without first contacting your Schneider Electric field sales representative.

Pre-Energizing Procedure Checklist

Conduct a complete inspection before the transformer is energized to ensure that all components function and operate properly. **Complete steps 1–22 before energizing the transformer.**

1. Check all field-installed electrical connections. Torque values are listed in Table 1 on page 15.
2. Check all accessible connections for tightness.
3. Check all factory and field-installed lug terminations for tightness.
4. Check the rigidity of all bushing and cable supports.
5. Check the enclosure for dents or other damage that reduce electrical clearances inside the compartment.
6. Remove all foam blocks, or other temporary cushioning or retaining material, from the electrical devices.
7. Manually open and close all switches, circuit breakers, and other operating mechanisms, checking for correct alignment and free operation.
8. Check all relays, meters, and instrumentation to verify that all field installed wiring connections are made properly and that the devices function properly.
9. Current transformers (CTs) supplied require connection to a metering device load before energizing. Verify that the metering device load is properly connected.

⚠ DANGER

HAZARD OF ELECTRIC SHOCK, EXPLOSION, OR ARC FLASH

Current transformer secondaries must be connected to a load or short-circuited before the transformer is energized to avoid hazardous voltage at the terminals.

Failure to follow this instruction will result in death or serious injury and equipment damage.

10. All CT circuits supplied by Schneider Electric for metering use are shorted for shipment. Remove shorting terminal screws on shorting terminal blocks or jumpers and store in the block.
11. On transformers with an electronic trip circuit breaker, set the tripping characteristic curve of the adjustable electronic trip unit as outlined in the respective instruction manual.

NOTE: For molded case circuit breakers, Schneider Electric manual number 0600PD9602, Field Testing Industrial Molded Case Circuit Breakers, provides more in-depth information. Contact your Schneider Electric field sales representative to obtain this manual.

⚠ DANGER

HAZARD OF ELECTRIC SHOCK, EXPLOSION, OR ARC FLASH

- If circuit breaker settings are adjusted, do not set the long time trip rating at a higher ampacity than the rating of the bus bar or load cables it supplies; overheating can occur.
- Before energizing the transformer, all unused I-Line® circuit breaker mounting spaces must be filled with blank fillers and/or extensions as listed in Table 4.

Failure to follow these instructions will result in death or serious injury.

Table 4: Blank Fillers and Extensions

	Height	Catalog No.
Blank Fillers	1.5 in. (38 mm)	HNM1BL
	4.5 in. (114 mm)	HNM4BL
Blank Extensions	1.5 in. (38 mm)	HLW1BL
	4.5 in. (114 mm)	HLW4BL

⚠ CAUTION

HAZARD OF EQUIPMENT DAMAGE

Do not remove the protective lubricant on the plug-on connectors.

Failure to follow this instruction can result in injury or equipment damage.

NOTE: If additional lubrication is required, apply a coating of electrical joint compound, catalog number PJC7201, to the plug-on connectors' contact surfaces.

12. Check all control wiring (when present) with the wiring diagrams to ensure that connections are properly made.
13. Inspect all insulation surfaces for dirt and moisture, including the primary support insulators and isolation barriers. If necessary, wipe with a clean cloth.
14. Fasten all barriers and covers in place.
15. Insert the proper keys in the interlocks, when used.
16. Verify that all grounding connections are correctly made.

⚠ CAUTION

HAZARD OF EQUIPMENT DAMAGE

Do not pry open or spread the fuse mounting clips. This can cause a loose connection, resulting in overheating.

Failure to follow this instruction can result in injury or equipment damage.

17. Conduct an electrical insulation resistance (megger) test to ensure that the transformer is free from short circuits and undesirable grounds.

18. After completing the electrical insulation resistance test, replace all control power fuses that may have been removed and close power disconnects that have been opened.
19. Check all field-installed wiring. Make certain it is clear of all live parts and secured to withstand fault currents.
20. Verify that all control wiring is properly connected.
21. Verify the position of the tap changer against the transformer nameplate information.
22. Remove all hand tools, equipment, or any other foreign materials from inside the compartment.

Verifying the Voltage is Correct

Do not energize the transformer with single phase switching and do not operate the transformers with any phases open. Use only ganged three phase switches to energize or de-energize the transformer. When steps 1 through 22 above have been completed, energize the transformer and follow steps 1–2 below to verify the voltage is correct.

⚠ DANGER

HAZARD OF ELECTRIC SHOCK, EXPLOSION, OR ARC FLASH

- Do not energize or de-energize the transformer with single phase switches.
- Do not operate the transformer with any phases open.
- Only qualified personnel with appropriate measurement devices should measure the voltages on the transformer.

Failure to follow these instructions will result in death, personal injury, or damage to the equipment.

1. Verify that the rating of the voltmeter is adequate for measuring the high voltage and low voltage rating of the transformer as listed on the transformer nameplate.
2. Using the voltmeter, verify the voltages on the transformer secondary. If the voltages are not as required, verify the primary voltage. Use the tap changer to adjust the voltage. See “Tap Changer” on page 16.

Inspection Following Energizing

After energizing the transformer, check the following:

- Inspect the dial-type thermometer and confirm the proper liquid temperature (see “Dial Thermometer” on page 23).
- Confirm that there are no leaks around bushing parts or weld seams.
- Confirm that there is no blue glow or partial discharge effect at the high voltage or low voltage terminations.
- When it is first energized, keep the transformer under observation during the first few hours.
- Make a periodic check of the load to ensure the transformer is not being subjected to excessive overload. Planned overloading should be in accordance with the ANSI Loading Guide (C57.91).

Sound Level

All transformers have an inherent sound level that varies with the size of the units. Sound waves may be amplified by means of reflected waves and/or radiated waves via walls, floors, ceilings, mechanical vibrations of air ducts, conduits, and mounting bases. For average expected sound levels, refer to NEMA ST-20.

To meet NEMA listed average sound levels, each unit should be installed in a location which provides a 10-foot clearance on all sides except floor or ground. Units located in close proximity to hard surfaces may produce higher than average sound levels. When transformers must be located in noise sensitive areas, precautions should be taken to avoid amplification of the transformer sound.

Install the unit in an area where the noise will be least objectionable. Avoid areas where hard surfaces are in close proximity to the transformer.

If the unit is installed indoors, use acoustic absorbing materials on walls, floors, and ceilings. Avoid installation of units in corners, hallways, and stairways, and near heating and air conditioning ducts.

Cabinet Security

⚠ DANGER

HAZARD OF ELECTRIC SHOCK, EXPLOSION, OR ARC FLASH

Properly secure the cabinet to prevent access by unauthorized personnel.

Failure to follow this instruction will result in death or serious injury or damage to equipment.

Before leaving the site of an energized transformer, make sure any protective or insulating barriers are in place, the cabinet is completely closed, and all locking provisions are properly installed.

Follow these procedures to help ensure cabinet security:

1. Close the high voltage (left) door and secure it in place with the captive bolts supplied (pentahead or hexhead).
2. Close the low voltage (right) door and secure it in place by rotating the handle in a clockwise direction until seated (the handle should then be in a vertical orientation).
3. Tighten the safety bolt (pentahead or hexhead) located in the locking tube until it is fully seated.
4. Install a padlock through the door handle and locking tube and secure it in place.
5. Check both the high and low voltage doors for proper fit and security.

SECTION 8—MAINTENANCE

Complete maintenance services are available from Square D Services. They can provide assistance in a variety of areas, from installation to comprehensive testing and verification of the new equipment. Contact Square D Services at 1-800-634-2003, 24-hours a day.

Scheduled Maintenance

Inspect the transformer regularly. The frequency of inspection depends on operating conditions. If the transformer is operating in usual service conditions as defined in ANSI/IEEE C57.12.00, an inspection every year may be sufficient. However, for unusual locations where the air is contaminated with particles such as dust or chemical fumes, inspect the transformer every three months or sooner. After the first few inspections, determine a more definite schedule based on the existing conditions. Complete the following maintenance checks.

⚠ DANGER

HAZARD OF ELECTRIC SHOCK, EXPLOSION, OR ARC FLASH

- Before performing these checks, review “Section 3— Safety Precautions”.
- Before servicing the transformer, ensure all static charge has been discharged by grounding the coils with an appropriate grounding device.

Failure to follow these instructions will result in death or serious injury.

- ❑ De-energize the transformer following the safety messages above and your facility’s lock-out/tag-out procedures.
- ❑ Check the transformer tank, radiators, and bushings for leaks and repair any leaks found (see “Liquid Leaks” on page 33).
- ❑ Check the liquid temperature and level. Add the proper liquid as required.
- ❑ Check and clean dirty bushings and surge arrestors with a clean, dry cloth, and replace any corroded hardware.
- ❑ Repair and repaint any damaged or corroded areas on the tank (see “Exterior Finish” on page 33).
- ❑ Check the torque values on all electrical connections, including the ground connections and tighten as necessary (see Table 1 on page 15).
- ❑ Ensure that all accessories (fans, gauges, relays, etc.) are operational.
- ❑ Replace any damaged or unreadable safety labels.
- ❑ Check enclosure integrity (hinges, locking provisions, corrosion, etc.)
- ❑ Check transformer tilt.

Maintenance Testing

The following tests are recommended to determine the condition of the transformer:

1. Insulation resistance (see page 26).
2. Insulation power factor.
3. Transformer Turns Ratio (TTR) (see page 27).
4. Dielectric strength, power factor, moisture content, and combustible gas analysis of the insulating liquid.

Maintenance for Accessories

Accessories such as the liquid temperature and level indicators, pressure vacuum gauge, pressure relief valve and pressure relief diaphragm, and drain and sampler valve require no maintenance except to be replaced in the event of accidental damage. Monitor each gauge on a regular basis to ensure internal pressures, liquid level, and temperature are within design limits.

Molded Case Circuit Breakers Inspection and Maintenance

Molded case circuit breakers manufactured by Schneider Electric are designed as totally sealed units requiring minimal periodic maintenance.

Exercise circuit breakers at least once a year to ensure proper operation. For general maintenance:

- Trip the circuit breaker by pushing the Push to Trip button located on the face of the circuit breaker. (On most molded case circuit breakers this button will be yellow). This procedure tests alarm switches if they are built into the circuit breaker, or electrical interlocks between two circuit breakers. This also exercises the trip mechanism.
- Manually open and close the circuit breaker two to three times.

Refer to individual circuit breaker instruction manuals shipped with the transformer for additional maintenance information, such as changing rating columns or adjustable settings and removing circuit breakers. If the instruction manual is not available, see “Section 10—Reference Publications” on page 38 of this manual for the appropriate number, and contact your Schneider Electric field sales representative to obtain this manual.

The universal test set, catalog number UTS3, is available to test all Schneider Electric circuit breakers equipped with Micrologic® trip units. It runs trip unit tests automatically, with prompts to the user for initial information. Test modules for each circuit breaker frame are used to store data necessary for automatic tests. Series B MICROLOGIC trip units require test module CBTMB, which is included in UTS3.

NOTE: Tests may be conducted with a circuit breaker installed; circuit breaker removal is not required. The transformer must be de-energized.

Ground Fault Protection Systems

Check the terminal connections on the ground fault protection system at least once a year for tightness and corrosion. If the system can be tested with or without tripping the main or branch device, directions for testing the system are in the device manual. Otherwise, testing the ground fault protection system will trip the main or branch device to which it is connected. If the ground fault sensor or relay is physically or electrically damaged, replace it.

If the ground fault protection system does not operate properly and additional equipment has been connected to the installation since the last maintenance test/check, de-energize the entire system and check for grounds on the neutral downstream from the main bonding jumper. If no downstream grounds are detected and the ground fault system is not operating properly, contact Square D Services at 1-800-634-2003. Likewise, if no additions have been made to the installation, and the ground fault protector does not operate properly, contact Square D Services.

Refer to the ground fault field test instruction manual for additional testing information. If the manual is not available, refer to “Section 10—Reference Publications” on page 38 to obtain the appropriate number. Contact your Schneider Electric field sales representative to obtain this manual.

Maintenance After a Major Fault

To perform maintenance after a major fault, follow steps 1–3:

1. If the transformer is not de-energized, de-energize the transformer following the safety messages on page 7 and your facility's lock-out/tag-out procedures.
2. Inspect the transformer for any evidence of damage (broken and/or leaking bushings, operation of pressure relief device or valve, etc.).

⚠ DANGER

HAZARD OF ELECTRIC SHOCK, EXPLOSION, OR ARC FLASH

Do not re-energize the transformer if it has been damaged.

Failure to follow this instruction will result in death or serious injury.

3. Perform the tests described in “Scheduled Maintenance” on page 30. DO NOT re-energize the transformer if the test results are not acceptable. If no damage has occurred and all test results are acceptable, perform maintenance by following the procedures in “Scheduled Maintenance” on page 30.

Exterior Finish

The standard outside finish for liquid insulated transformers is satisfactory for widely diverse atmospheric conditions. However if the paint is damaged, the tank exterior metal is susceptible to rusting. All exposed metal surfaces must be thoroughly cleaned and prepared for the application of touch-up paint since the proper preparation of surfaces to be finished is an important factor in securing a satisfactory and lasting finish and maximizing the tank wall and radiator cooling effectiveness. Touch-up paint may be ordered from Schneider Electric. See "Section 9—Replacement Parts" on page 38.

Regardless of how good the paint may be, it will fail as a protector if applied over a wet, dirty, rusty, or greasy surface. Rust and scale will absorb and hold moisture. Therefore, to obtain a durable finish, it is absolutely essential that no moisture be sealed in by the application of paint. For large areas, to obtain a clean, dry surface with sufficient roughness for good adhesion of the priming coat, shot- or sand-blast the exposed surfaces of the transformer tank.

Locating Pressure Leaks Above the Liquid Level

Each transformer is pressure tested at the factory to ensure a pressure-tight seal, preventing moisture contamination of the liquid coolant. Review "Receiving" on page 8 for initial inspection and methods of verifying the pressure seal. If the seal is broken due to mishandling or other adverse conditions, locate and repair the leak point as follows:

Apply dry air or nitrogen with a dew point of -50 °C (-58 °F) through the Schraeder valve in the tank wall. Do not apply through the pressure-vacuum bleeder valve. Apply a solution of soap and glycerin to all seams and joints above the liquid level. As the pressure rises to 5 psi, any bubbling of the soap solution will pinpoint the location of a pressure leak. Patch the leak by tightening devices at the point of the leak, applying epoxy patches, or welding.

Liquid Leaks

<p>⚠ DANGER</p> <p>HAZARD OF ELECTRIC SHOCK, EXPLOSION, OR ARC FLASH</p> <p>De-energize the transformer before performing any maintenance procedures.</p> <p>Failure to follow this instruction will result in death or serious injury.</p>
--

Liquid coolant leaks are rare, but if detected, repair them at once to avoid the liquid level dropping below energized parts, creating a possibility of flashover or transformer overheating. To repair a weld leak in a tank seam or around one of the fittings, follow steps 1–9:

1. De-energize the transformer following the safety precautions listed on page 7 and your facility's lock-out/tag-out procedures. Check the liquid level in relation to the area to be welded. It should be 4 in. (102 mm) or more above the area to be welded. Should the area to be welded be above the liquid or if the liquid has been removed from the tank, blanket the transformer with dry nitrogen.
2. If the liquid has not been removed, pull a vacuum of several psi above the liquid to stop the liquid leak. This may be done with a vacuum pump or by sealing all fittings on the tank and draining sufficient liquid to obtain the necessary vacuum.

NOTE: Vacuum is not always required, especially when a sweating leak is to be repaired and the tank wall is relatively thick.

3. Peen the weld leak closed, if possible, with the ball end of a ball-peen hammer or with a blunt or round-nosed chisel.
4. Grind or scrape the paint from the area to be welded and prepare a suitable point for attaching the ground lead to the arc welding machine.
5. Select a 1/8 in. diameter all-purpose coated electrode. Either ac or dc welding current may be used. When dc current is used, straight polarity (the electrode is negative) is preferred. Adjust the welding machine to supply the desired welding current. Depending on the welding operator's

ability and the individual task at hand, set the welding current between 115 and 125 A.

6. Apply a string bead sealing weld over the weld defect in a single, quick pass. This weld may be deposited horizontally or vertically depending upon circumstances. If the weld is deposited vertically, make it downward to drive any liquid seepage ahead of the weld. Remove the slag from the deposited weld before depositing each successive weld pass.

Liquid interferes with the welding operation and the quality of the deposited metal. Wipe off any liquid with a dry cloth. Deposit all welds in a sequence as described above to prevent any liquid seepage from interfering with the welding operation other than the final sealing at the lowest point of the weld leak.

7. Clean the repaired area and check with a suitable leak detector to be sure the leak has been stopped.
8. After testing for leaks, reclean the area and apply touch-up paint.
9. If required, refill the transformer to its proper operating level (see “Draining and Filling the Tank” on page 35).

Small Pin-Hole Leaks

⚠ DANGER

HAZARD OF ELECTRIC SHOCK, EXPLOSION, OR ARC FLASH

De-energize the transformer before performing any maintenance procedures.

Failure to follow this instruction will result in death or serious injury.

Small pin-hole leaks in the exterior metal, weld seam, etc., resulting in slow dripping, can be repaired with a durable epoxy patch kit. First de-energize the transformer following the safety precautions listed on page 7 and your facility’s lock-out/tag-out procedures, then apply a temporary liquid stick before the epoxy. In most cases this eliminates the need for a vacuum pump to stop the liquid leak while the epoxy is curing. Larger leaks may require the use of a vacuum pump. Detailed instructions are included with the epoxy repair kit.

Welding of small leaks can also be accomplished in the field on de-energized transformers, however avoid penetrating the metal and creating a more serious leak. **Welding on radiator metal is not recommended due to the thinner gauge material. See “Liquid Leaks” on page 33.**

Bushing Leaks

Some bushing leaks at the bushing connector may be corrected by tightening the metal terminator part of the bushing. Leaks between the bushing and the tank wall may be corrected by tightening the bushing clamp bolts.

NOTE: Do not exceed 40–60 lb-in. (5–7 N•m) torque on the bushing clamp bolts or terminals to avoid cracking the bushing material.

Maintenance of Internal Features

The transformer normally does not require internal maintenance throughout its life except for periodic sampling of the liquid coolant. The unit is shipped from the factory with the tank sealed. If inspection or repair of the internal tank parts is necessary, be careful to reseal the openings properly on completion of the work.

Sampling the Liquid

The dielectric strength of liquid is affected by the most minute traces of certain impurities, particularly water. To avoid contamination, use great care in obtaining and handling the samples. When sampling the liquid, use a clean, dry, dark glass bottle or jar with a cork stopper. Do not use a rubber stopper or a sealing lid with a rubber gasket since the sulfur in natural rubber can easily contaminate the liquid. Clean the bottle by washing it with non-leaded gasoline followed by strong soap, and rinsing it with distilled water before drying. Be careful to procure a sample that fairly represents the liquid at the bottom of the tank by drawing off a sufficient amount of liquid

before taking the sample. This ensures that the sample is not liquid that was stored in the sampling pipe.

Open the drain valve or plug and release a small amount of the liquid coolant to flush out the valve and plug opening. The valve and drain pipe should be small enough to be emptied conveniently and large enough to give an even flow of liquid and avoid clogging by sediment. Take a quart sample, leaving space in the jar for expansion. Seal the jar and send it to the nearest testing facility for testing in accordance with ANSI standards. Testing must include as a minimum dielectric strength, power factor, and moisture content.

It is essential that the sample of insulating liquid represent the actual condition of the liquid in the transformer. Take every precaution to keep the sample and container free from foreign impurities or moisture. If the transformer is installed outdoors, be careful to prevent contamination of the sample by rain, snow, etc.

Receiving, Storing, and Handling the Liquid

If liquid is received in drums, as soon as they are unloaded, examine the bungs for damage or leaks. Store the drums in a closed room. Do not store the liquid outdoors since it is hazardous to the liquid. Store the drums with the bung down so the bung is under positive pressure. Do not open a drum until the liquid is needed. Tightly reseal any partially emptied containers and store them the same as new drums.

Like liquid purchased in drums, do not expose one- and five-gallon cans of liquid to the weather. Keep the seal intact until the liquid is needed. It is not necessary to perform dielectric tests on liquid in sealed cans. If a can is not completely emptied, use the provided screw cap to prevent contamination by moisture and dirt. The liquid in a partially used can must be tested before using it.

Draining and Filling the Tank

De-energize the transformer following the safety message on page 7 and your facility's lock-out/tag-out procedures.

<p style="text-align: center;">⚠ DANGER</p> <p>FLAMMABLE LIQUID. RISK OF FIRE OR EXPLOSION</p> <ul style="list-style-type: none">• Purge the gas space with nitrogen before adding/filling the transformer with liquid.• Ground the transformer, transformer bushings, and all liquid-handling equipment. <p>Failure to follow this instruction will result in death or serious injury and damage to equipment.</p>

Transformer liquid should be considered and handled as a flammable liquid. Under certain conditions, the closed transformer tank may contain combustible gases, and filling procedures may generate static electricity. Purge the gas space with nitrogen and ground all equipment following the safety message above.

When adding liquid to the transformer, take the precautions necessary to prevent PCB contamination. When draining or filling the tank, be careful to avoid contamination of the stored liquid. Use chemically cleaned and dry barrels or storage containers. Before opening the storage containers, allow them to reach the ambient temperature to avoid condensation. Use hoses and fittings that are liquid-resistant to avoid sulfur contamination. Remove the fill plug to equalize the tank pressure while draining. Drain the tank from the drain valve and plug location into the storage containers. When filled, properly seal the storage containers.

Before filling the tank, tightly seal all fittings. Fill the tank through the upper fill plug. Use of a filter press is recommended when filling to ensure the liquid is free from moisture, air, or solid contamination. After filling the tank, test the liquid quality and tank seal.

NOTE: Never fill or add liquid to the transformer through the drain valve.

⚠ DANGER

HAZARD OF ELECTRIC SHOCK, EXPLOSION, OR ARC FLASH

Do not re-energize the transformer before draining or adding liquid.

Failure to follow this instruction will result in death or serious injury and damage to equipment.

Reconditioning the liquid consists of removing water, carbon gases, and sludge. Four types of equipment are generally used: centrifuge, blotter filter press, and a combination of fullers earth and vacuum dehydration process.

In general, when large quantities of liquid have been contaminated, it is preferable to replace the liquid rather than attempt to reclaim it. When small quantities of liquid have been contaminated, the reclamation process depends on the kind and degree of contamination. Contact your local Schneider Electric field sales representative for recommendations and instructions.

Opening the Transformer Tank

Transformers are shipped sealed and in most cases need not be opened. If it should become necessary to open the tank to gain internal access, follow steps 1–7:

⚠ DANGER

HAZARD OF ELECTRIC SHOCK, EXPLOSION, OR ARC FLASH

De-energize the transformer before opening the transformer.

Failure to follow this instruction will result in death or serious injury and damage to equipment.

1. De-energize the transformer following the safety message above and on page 7, and your facility's lock-out/tag-out procedures.

⚠ DANGER

HAZARDOUS PRESSURE. RISK OF FLYING OBJECTS.

Release the internal pressure before removing accessories or hand-hole inspection covers.

Failure to follow this instruction will result in death or serious injury and damage to equipment.

2. Release the internal pressure by operating the pressure relief valve, or by slowly removing the filling plug a thread at a time until the pressure starts to relieve itself.
3. Do not open the transformer in an area that is unprotected from the weather if there is a possibility of precipitation, or in an area where the air contains dirt or other particles. When the transformer is opened, protect the opening from foreign matter. Do not permit anyone on the tank cover until they have emptied all pockets of loose objects, and removed watches, rings, etc.

4. Clean off the cover of the transformer to prevent the entrance of any dirt or foreign material when the cover is opened.
5. Remove the tamper-proof cover over the hand hole cover by removing the nuts holding it in place. These nuts are located inside the high- and low-voltage compartments. Slide the tamper-proof cover back and lift it off.
6. Remove the hand hole cover by removing the nuts holding it in place and lifting it off.

⚠ DANGER

HAZARD OF SUFFOCATION

Purge the gas space with dry air before entering the transformer tank.

Failure to follow this instruction will result in death or serious injury.

7. Purge the gas space with dry air. Never enter the transformer tank until an analysis of the air in the tank shows at least 19.5% oxygen.
8. To ventilate the inside of the tank while it is open, use dry air with a dew point of -50 °C (-58 °F) or lower. If dry air is not available, outside air may be used to ventilate the transformer as long as the outside relative humidity is less than 60% and the temperature of the transformer is at least 10 °C higher than the dew point of the outside air.
9. Tie off all tools outside the cover opening before using them inside the tank. Air hoses may be placed inside the transformer tank if they are clean and are made of material resistant to the liquid in the transformer.
10. If it is necessary to lower the liquid level, see “Draining and Filling the Tank” on page 35.

The maximum time that the transformer can be open is 12 hours. If this time must be exceeded, contact your local Schneider Electric field sales representative for instructions.

Entering the Transformer Tank

If it is necessary to enter the tank, first make sure an analysis of the air in the tank shows at least 19.5% oxygen. Use clean drop cloths under the working area to prevent objects from falling into the core and coil assembly. Wear clean cloth covers over shoes and never stand on any electrical insulation. Whenever anyone is inside the tank, station a second person at the opening in the cover of the tank to ensure the safety of the person inside. Follow all OSHA “confined space” entry rules and regulations.

Closing the Transformer Tank

After completing work inside the transformer tank, follow steps 1–3:

1. Clean the contact surfaces of the hand hole gasket and cover. If the gasket has been damaged in any way, replace the gasket.
2. Replace the transformer hand-hole cover and tighten the nuts evenly around the cover. Refill the transformer with any liquid that was removed. See “Draining and Filling the Tank” on page 35.
3. Perform the tests described in “Scheduled Maintenance” on page 30.
4. Pressure test the transformer for leaks as described in “Locating Pressure Leaks Above the Liquid Level” on page 33.
5. Replace the tamper-proof cover over the hand hole cover.

Repairs

It is the responsibility of the owner to inspect and maintain the transformer and keep it in good repair.

Report all problems during the warranty period to your Schneider Electric field sales representative. All warranty repairs must be made by Schneider Electric or an approved service facility.

To assure proper operation, use only Schneider Electric approved replacement parts.

Schneider Electric recommends that the owner limit repairs to replacing broken parts, unless the owner has well-trained repair personnel.

Some internal parts can be replaced without completely draining the tank. In such cases, only the liquid necessary to expose the part should be drained. There may be occasions when complete draining of the transformer tank is required.

The core and coil assembly can be repaired or replaced by Schneider Electric personnel at either the factory, or at an authorized repair facility. For details, contact Schneider Electric.

SECTION 9—REPLACEMENT PARTS

The following parts are possible field-replaceable parts. Because of the wide variety of sizes, ratings, types, and styles used on different ratings and types of transformers, it is not possible to give a part number that will match your specific transformer. If a replacement or spare is needed, order by its name, along with the serial number, voltage ratings, and kVA size of the transformer, and any other information that will enable us to locate the original records on a specific transformer. Order from your local Schneider Electric representative.

- Thermometer
- Pressure/vacuum gauge
- Pressure relief valve
- Liquid level gauge
- Pressure relief device
- Drain valve
- Touch-up paint
- Fill valve
- Current transformer
- Safety labels
- Circuit breaker
- Terminal or ground lugs
- High voltage bushing
- Low voltage bushing
- Neutral bushing
- Tap changer

SECTION 10—REFERENCE PUBLICATIONS

The following Schneider Electric publications are available through your Schneider Electric field sales representative. These include device replacement procedures and spare parts listings to make ordering and servicing of replacement parts quick and convenient. Any maintenance procedure or device not listed, such as an I-Line® panel, is not customer serviceable. Contact your field sales representative for information.

Table 5: Installation Instructions

Title	Publication Number
FA, FH, FC, SFH Circuit Breakers	48940-158-02
NA, NC, SL 1200 I-Line® Circuit Breakers	48040-797-04
LI, LC I-LINE Circuit Breakers	48040-732-03
KA, KH, KC, KI, SKC, SKI Instructions	48049-031-02
FI Instructions	48049-033-01
LA, LH, SLA, Q4 Instructions	48049-034-02
Q2 Instruction Sheet	48040-008-08
MA, MH, SMA, SMH Instructions	48049-032-02
PA, PH Instruction Sheet	48040-189-05
FA-M01 and KA-M01 Motor Operator	48049-085-01
LA-M01 and MA-M01 Motor Operator	48049-086-01

Table 5: Installation Instructions

Title	Publication Number
PA-M02 Motor Operator	48040-884-06
SE Electronic Trip Circuit Breaker with Micrologic® Trip System	48040-495-07
Ground Fault Module (GFM)	48040-756-05
Ground Fault Protection System—Type GC	40268-292-01
Masterpact® Universal Power Circuit Breaker	48049-071-02
QMB Fusible Switches	40268-525-02

Table 6: Instruction and Maintenance Bulletins

Title	Publication Number
LE/LX Manual	48049-027-02
ME, MX Electronic Trip Circuit Breakers	48049-028-02
NE, NX Drawout Circuit Breakers	48049-029-01
PE/PX Manual	48040-940-03
SE Electronic Trip Circuit Breaker	48040-495-06

Table 7: Ground Fault Field Test Instructions

Title	Publication Number
Ground Fault Module (GFM) Field Test Procedure	48040-757-04
ME/NE/PE and MX/NX/PX Electronic Trip Circuit Breakers	63020-271-01
Type GC—Ground Fault Protection System	80043-054-01

Table 8: Distribution Reference Catalogs

Title	Section Number
Molded Case Circuit Breakers	600
QMB Fusible Switches	4620
QMB Circuit Breaker Adapter Units	4620

Table 9: Other Reference Literature

Title	Publication Number
Application Guide for Ground Fault Protective Devices for Equipment	NEMA Publication PB2.2
Circuit Breakers	NEMA Publication AB-4
Enclosed and Miscellaneous Distribution Switches	NEMA Publication KS-1
Electrical Equipment Maintenance	NFPA 70B-1999
Molded Case Circuit Breakers Field Test and Maintenance	Schneider Electric Bulletin No. 0600PD9602

For information about obtaining NEMA documents, write to:

National Electrical Manufacturers Association (NEMA)
Attention: Customer Service
1300 North 17th Street
Suite 1847
Rosslyn, VA 22209

You can also visit the NEMA web site at www.nema.org.

Instruction Bulletin
Three Phase, Liquid Filled, Compartmental Type, Pad Mounted Transformers

Schneider Electric

1010 Airpark Center Drive
Nashville, TN 37217 USA
1-888-SquareD
(1-888-778-2733)
www.SquareD.com

Electrical equipment should be installed, operated, serviced, and maintained only by qualified personnel. No responsibility is assumed by Schneider Electric for any consequences arising out of the use of this material.

43500-054-03R2 © 2002–2004 Schneider Electric All Rights Reserved
Replaces 43500-054-03R1 dated June 2002

**SQUARE D COMPANY
CERTIFIED TRANSFORMER TEST REPORT**

Serial Number :	27280249-005-01	Shop Order :	10J595127
Customer Name :	AMERICAN ELECTRIC CO	Project Name :	ASR - PHASE II
Purchase Order :	2-SHEL-09180	Sub/Phase Polarity:	N/A
3PH 60 Hertz Coolant - MINERAL OIL		K Factor:	NA
Winding High Voltage		Winding Low Voltage	
750 KVA PAD		750 KVA	
12470 Volts		480Y/277 Volts	
Taps :	13095 12785 12470 12160 11850		

Resistance, losses, impedance and regulation corrected to 85 degree C and are based on wattmeter reading unless otherwise stated. The resistance for 3 phase transformers is the sum of the 3 phases in series.

Test Date	Resistance(Ohms)		%Exc Amps	Losses			%Imp	%R	%X	X/R	
	H.V	L.V		No Load	Load	Total					
10/25/2010	8.7375	.00342	0.18	953	6,617	7,569	5.57	0.88	5.50	6.23	
	Guarantee						5.75				

Regulation					
PF	100%	90%	85%	80%	75%
	1.03	3.31	3.75	4.08	4.35

Temperature rise calculated from basic design data which has been verified by test results of similar unit (Serial Number = 06J528200, High Voltage = 11000, Date = 04/09/2006)

Winding Rise by Resistance in degree C				
Load	H.V	L.V	Guarantee	Top Fluid
Base	48.7	55.8	65	45.1

Insulation Test			
Applied Potential Test			
Winding	Rated Volts	Test Volts applied	Duration of test
H.V	12470	34000	60 Sec
L.V	480	10000	60 Sec

Qa` & aA[c) cae` d
X[ca^ A^i €
C]] a a^ i a@ A^ &] a a^` D

Insulation Power factor % Corrected to 20 Deg C		
CH	CL	CHL
N/A	N/A	N/A

Sound Test : Test result from a similar unit
(Serial Number = 07J795291, High Voltage = 13200, Date = 6/11/2007)

ONAN(db)	ONAF(db)
50.2	N/A

Efficiency				
125%	100%	75%	50%	25%
98.81	99.00	99.18	99.31	99.29

Liquid Testing		
PF	Water	Dielectric
N/A	N/A	N/A

Unit contained less than 1PPM PCB at the time of manufacture.

Pressure Test Results:
Unit Successfully Passed QC Impulse Test.
Unit was leak tested and no detectable leaks were found.

I hereby certify that this is a true report based on factory tests made in accordance with the latest IEEE/ANSI C571290 and C571200 and that each transformer withstood the insulation tests.



>c\b`K `7fchmz`D`9"
9b[]bYYf]b[`A UbU[Yf
8]grf]Vi h]cb HfUbgzcf a Yfg 8]]g]cb

**SQUARE D COMPANY
CERTIFIED TRANSFORMER TEST REPORT**

Ratio Test Results

DV Position	Tap Position	Tap	Phase A	Phase B	Phase C	Vector
	1	13090	47.23030	47.23000	47.23100	DY1
	2	12780	46.11570	46.11830	46.11950	DY1
	3	12470	45.00750	45.00720	45.01010	DY1
	4	12160	43.89860	43.89950	43.89990	DY1
	5	11850	42.78690	42.78690	42.78890	DY1

**SQUARE D COMPANY
CERTIFIED TRANSFORMER TEST REPORT**

Serial Number : 27280249-004-01	Shop Order : 10J595126
Customer Name : AMERICAN ELECTRIC CO	Project Name : ASR - PHASE II
Purchase Order : 2-SHEL-09180	Sub/Phase Polarity: N/A
3PH 60 Hertz Coolant - MINERAL OIL	K Factor: NA
Winding High Voltage	Winding Low Voltage
1500/1680 KVA PAD	1500/1680 KVA
12470 Volts	480Y/277 Volts
Taps : 13095 12785 12470 12160 11850	

Resistance, losses, impedance and regulation corrected to 75 degree C and are based on wattmeter reading unless otherwise stated. The resistance for 3 phase transformers is the sum of the 3 phases in series.

Test Date	Resistance(Ohms)		%Exc Amps	Losses			%Imp	%R	%X	X/R	
	H.V	L.V		No Load	Load	Total					
10/26/2010	3.6669	.00124	0.24	1,918	10,401	12,319	5.91	0.71	5.87	8.24	
	Guarantee						5.75				

Regulation					
PF	100%	90%	85%	80%	75%
	0.88	3.34	3.82	4.18	4.48

Temperature rise calculated from basic design data which has been verified by test results of similar unit (Serial Number = 06J649179, High Voltage = 13200, Date = 10/24/2006)

Winding Rise by Resistance in degree C				
Load	H.V	L.V	Guarantee	Top Fluid
Base	49.2	49.5	55	48.8

Insulation Test			
Applied Potential Test			
Winding	Rated Volts	Test Volts applied	Duration of test
H.V	12470	34000	60 Sec
L.V	480	10000	60 Sec

Qä` & äÄj () ääe` d
X[ää^Äj €
() ääÄj ää^Äj) ääe` d

Insulation Power factor % Corrected to 20 Deg C		
CH	CL	CHL
N/A	N/A	N/A

Sound Test : Test result from a similar unit
(Serial Number = 07J778165, High Voltage = 12470, Date = 3/1/2007)

ONAN(db)	ONAF(db)
55.9	N/A

Efficiency				
125%	100%	75%	50%	25%
99.04	99.19	99.32	99.40	99.33

Liquid Testing		
PF	Water	Dielectric
N/A	N/A	N/A

Unit contained less than 1PPM PCB at the time of manufacture.

Pressure Test Results:
Unit Successfully Passed QC Impulse Test.
Unit was leak tested and no detectable leaks were found.

I hereby certify that this is a true report based on factory tests made in accordance with the latest IEEE/ANSI C571290 and C571200 and that each transformer withstood the insulation tests.



>c\b`K `7fchmz`D`9"
9b[]bYYf]b[`A UbU[Yf
8]gfr]Vi h]cb HfUbgzcfA Yfg8j]]g]cb

**SQUARE D COMPANY
CERTIFIED TRANSFORMER TEST REPORT**

Ratio Test Results

DV Position	Tap Position	Tap	Phase A	Phase B	Phase C	Vector
	1	13090	47.23940	47.23890	47.24110	DY1
	2	12780	46.16370	46.16430	46.16610	DY1
	3	12470	45.01080	45.01160	45.01330	DY1
	4	12160	43.85750	43.85810	43.85880	DY1
	5	11850	42.78020	42.77890	42.78280	DY1

**SQUARE D COMPANY
CERTIFIED TRANSFORMER TEST REPORT**

Serial Number :	27280249-003-01	Shop Order :	10J595125
Customer Name :	AMERICAN ELECTRIC CO	Project Name :	ASR - PHASE II
Purchase Order :	2-SHEL-09180	Sub/Phase Polarity:	N/A
3PH 60 Hertz Coolant - MINERAL OIL		K Factor:	NA
Winding High Voltage		Winding Low Voltage	
1500/1680 KVA PAD		1500/1680 KVA	
12470 Volts		480Y/277 Volts	
Taps :	13095 12785 12470 12160 11850		

Resistance, losses, impedance and regulation corrected to 75 degree C and are based on wattmeter reading unless otherwise stated. The resistance for 3 phase transformers is the sum of the 3 phases in series.

Test Date	Resistance(Ohms)		%Exc Amps	Losses			%Imp	%R	%X	X/R	
	H.V	L.V		No Load	Load	Total					
10/26/2010	3.5913	.00125	0.24	1,892	10,300	12,192	5.84	0.71	5.80	8.22	
	Guarantee						5.75				

Regulation					
PF	100%	90%	85%	80%	75%
	0.87	3.30	3.77	4.13	4.43

Temperature rise calculated from basic design data which has been verified by test results of similar unit (Serial Number = 06J649179, High Voltage = 13200, Date = 10/24/2006)

Winding Rise by Resistance in degree C				
Load	H.V	L.V	Guarantee	Top Fluid
Base	49.2	49.5	55	48.8

Insulation Test			
Applied Potential Test			
Winding	Rated Volts	Test Volts applied	Duration of test
H.V	12470	34000	60 Sec
L.V	480	10000	60 Sec

Qä` & äÄj () ääe` d
X[ää^Äj €
() ääÄj ää^Äj ää` D

Insulation Power factor % Corrected to 20 Deg C		
CH	CL	CHL
N/A	N/A	N/A

Sound Test : Test result from a similar unit
(Serial Number = 07J778165, High Voltage = 12470, Date = 3/1/2007)

ONAN(db)	ONAF(db)
55.9	N/A

Efficiency				
125%	100%	75%	50%	25%
99.05	99.19	99.32	99.41	99.34

Liquid Testing		
PF	Water	Dielectric
N/A	N/A	N/A

Unit contained less than 1PPM PCB at the time of manufacture.

Pressure Test Results:
Unit Successfully Passed QC Impulse Test.
Unit was leak tested and no detectable leaks were found.

I hereby certify that this is a true report based on factory tests made in accordance with the latest IEEE/ANSI C571290 and C571200 and that each transformer withstood the insulation tests.



>c\b`K `7fchmz`D`9"
9b[]bYYf]b[`A UbU[Yf
8]grf]Vi h]cb HfUbgzcfA Yfg8j]]g]cb

SQUARE D COMPANY
CERTIFIED TRANSFORMER TEST REPORT

Ratio Test Results

DV Position	Tap Position	Tap	Phase A	Phase B	Phase C	Vector
	1	13090	47.23920	47.24170	47.24380	DY1
	2	12780	46.16590	46.16700	46.16970	DY1
	3	12470	45.00960	45.01390	45.01630	DY1
	4	12160	43.85700	43.85980	43.86130	DY1
	5	11850	42.77790	42.78090	42.78380	DY1

**SQUARE D COMPANY
CERTIFIED TRANSFORMER TEST REPORT**

Serial Number :	27280249-002-01	Shop Order :	10J595124
Customer Name :	AMERICAN ELECTRIC CO	Project Name :	ASR - PHASE II
Purchase Order :	2-SHEL-09180	Sub/Phase Polarity:	N/A
3PH 60 Hertz Coolant - MINERAL OIL		K Factor:	NA
Winding High Voltage		Winding Low Voltage	
1500 KVA PAD		1500 KVA	
12470 Volts		480Y/277 Volts	
Taps :	13095 12785 12470 12160 11850		

Resistance, losses, impedance and regulation corrected to 85 degree C and are based on wattmeter reading unless otherwise stated. The resistance for 3 phase transformers is the sum of the 3 phases in series.

Test Date	Resistance(Ohms)		%Exc Amps	Losses			%Imp	%R	%X	X/R	
	H.V	L.V		No Load	Load	Total					
10/26/2010	3.58785	.00126	0.29	1,911	10,579	12,490	5.73	0.71	5.69	8.07	
	Guarantee						5.75				

Regulation					
PF	100%	90%	85%	80%	75%
	0.87	3.25	3.71	4.06	4.35

Temperature rise calculated from basic design data which has been verified by test results of similar unit (Serial Number = 06J591213, High Voltage = 11000, Date = 08/07/2006)

Winding Rise by Resistance in degree C				
Load	H.V	L.V	Guarantee	Top Fluid
Base	57.1	60.1	65	62.5

Insulation Test			
Applied Potential Test			
Winding	Rated Volts	Test Volts applied	Duration of test
H.V	12470	34000	60 Sec
L.V	480	10000	60 Sec

Qä` & äÄj () ääe • d
X[ää ^ ÄÄj €
()] ä ä Ä ä @ Ä ^ & } ä ä ð D

Sound Test : Test result from a similar unit
(Serial Number = 07J778165, High Voltage = 12470, Date = 3/1/2007)

Insulation Power factor % Corrected to 20 Deg C		
CH	CL	CHL
N/A	N/A	N/A

ONAN(db)	ONAF(db)
55.9	N/A

Efficiency				
125%	100%	75%	50%	25%
99.03	99.17	99.31	99.40	99.33

Liquid Testing		
PF	Water	Dielectric
N/A	N/A	N/A

Unit contained less than 1PPM PCB at the time of manufacture.

Pressure Test Results:
Unit Successfully Passed QC Impulse Test.
Unit was leak tested and no detectable leaks were found.

I hereby certify that this is a true report based on factory tests made in accordance with the latest IEEE/ANSI C571290 and C571200 and that each transformer withstood the insulation tests.



>c\b`K `7fchmz`D`9"
9b[]bYYf]b[`A UbU[Yf
8]gfr]Vi h]cb HfUbgzcf a Yfg 8j]]gcb

SQUARE D COMPANY
CERTIFIED TRANSFORMER TEST REPORT

Ratio Test Results

DV Position	Tap Position	Tap	Phase A	Phase B	Phase C	Vector
	1	13090	47.23780	47.24010	47.23920	DY1
	2	12780	46.16350	46.16340	46.16350	DY1
	3	12470	45.01060	45.01150	45.01330	DY1
	4	12160	43.85570	43.85610	43.85930	DY1
	5	11850	42.77780	42.77890	42.78030	DY1

**SQUARE D COMPANY
CERTIFIED TRANSFORMER TEST REPORT**

Serial Number :	27280249-001-01	Shop Order :	10J596172
Customer Name :	AMERICAN ELECTRIC CO	Project Name :	ASR - PHASE II
Purchase Order :	2-SHEL-09180	Sub/Phase Polarity:	N/A
3PH 60 Hertz Coolant - MINERAL OIL		K Factor:	NA
Winding High Voltage		Winding Low Voltage	
1500/1680 KVA PAD		1500/1680 KVA	
12470 Volts		480Y/277 Volts	
Taps :	13095 12785 12470 12160 11850		

Resistance, losses, impedance and regulation corrected to 75 degree C and are based on wattmeter reading unless otherwise stated. The resistance for 3 phase transformers is the sum of the 3 phases in series.

Test Date	Resistance(Ohms)		%Exc Amps	Losses			%Imp	%R	%X	X/R	
	H.V	L.V		No Load	Load	Total					
10/27/2010	3.60705	.00128	0.26	1,892	10,427	12,319	5.74	0.71	5.70	7.98	
	Guarantee						5.75				

Regulation					
PF	100%	90%	85%	80%	75%
	0.88	3.26	3.72	4.07	4.37

Temperature rise calculated from basic design data which has been verified by test results of similar unit (Serial Number = 06J649179, High Voltage = 13200, Date = 10/24/2006)

Winding Rise by Resistance in degree C				
Load	H.V	L.V	Guarantee	Top Fluid
Base	49.2	49.5	55	48.8

Insulation Test			
Applied Potential Test			
Winding	Rated Volts	Test Volts applied	Duration of test
H.V	12470	34000	60 Sec
L.V	480	10000	60 Sec

Qä` & äÄj () ääe` d
X[ää^Äj €
() ääÄj ää^Äj) ääe` D

Insulation Power factor % Corrected to 20 Deg C		
CH	CL	CHL
N/A	N/A	N/A

Sound Test : Test result from a similar unit
(Serial Number = 07J778165, High Voltage = 12470, Date = 3/1/2007)

ONAN(db)	ONAF(db)
55.9	N/A

Efficiency				
125%	100%	75%	50%	25%
99.04	99.19	99.32	99.40	99.33

Liquid Testing		
PF	Water	Dielectric
N/A	N/A	N/A

Unit contained less than 1PPM PCB at the time of manufacture.

Pressure Test Results:
Unit Successfully Passed QC Impulse Test.
Unit was leak tested and no detectable leaks were found.

I hereby certify that this is a true report based on factory tests made in accordance with the latest IEEE/ANSI C571290 and C571200 and that each transformer withstood the insulation tests.



>c\b`K `7fchmz`D`9"
9b[]bYYf]b[`A UbU[Yf
8]gfr]Vi h]cb HfUbgzcf a Yfg 8j]]gcb

SQUARE D COMPANY
CERTIFIED TRANSFORMER TEST REPORT

Ratio Test Results

DV Position	Tap Position	Tap	Phase A	Phase B	Phase C	Vector
	1	13090	47.25670	47.24700	47.25890	DY1
	2	12780	46.17900	46.16910	46.18110	DY1
	3	12470	45.02500	45.01790	45.02800	DY1
	4	12160	43.87040	43.86220	43.87330	DY1
	5	11850	42.79410	42.78450	42.79670	DY1

**SQUARE D COMPANY
CERTIFIED TRANSFORMER TEST REPORT**

Serial Number : 27280249-006-01	Shop Order : 10J595128
Customer Name : AMERICAN ELECTRIC CO	Project Name : ASR - PHASE II
Purchase Order : 2-SHEL-09180	Sub/Phase Polarity: N/A
3PH 60 Hertz Coolant - MINERAL OIL	K Factor: NA
Winding High Voltage	Winding Low Voltage
750 KVA PAD	750 KVA
12470 Volts	480Y/277 Volts
Taps : 13095 12785 12470 12160 11850	

Resistance, losses, impedance and regulation corrected to 85 degree C and are based on wattmeter reading unless otherwise stated. The resistance for 3 phase transformers is the sum of the 3 phases in series.

Test Date	Resistance(Ohms)		%Exc Amps	Losses			%Imp	%R	%X	X/R	
	H.V	L.V		No Load	Load	Total					
10/23/2010	9.006	.00334	0.22	973	6,802	7,775	6.16	0.91	6.09	6.71	
	Guarantee						5.75				

Regulation					
PF	100%	90%	85%	80%	75%
	1.09	3.62	4.10	4.47	4.78

Temperature rise calculated from basic design data which has been verified by test results of similar unit (Serial Number = 06J528200, High Voltage = 11000, Date = 04/09/2006)

Winding Rise by Resistance in degree C				
Load	H.V	L.V	Guarantee	Top Fluid
Base	48.7	55.8	65	45.1

Insulation Test			
Applied Potential Test			
Winding	Rated Volts	Test Volts applied	Duration of test
H.V	12470	34000	60 Sec
L.V	480	10000	60 Sec

Qa` & aA[c) cae` d
X[ca^ A^i €
C]] a a^ i a@ A^ & } aæ` D

Insulation Power factor % Corrected to 20 Deg C		
CH	CL	CHL
N/A	N/A	N/A

Sound Test : Test result from a similar unit
(Serial Number = 07J795291, High Voltage = 13200, Date = 6/11/2007)

ONAN(db)	ONAF(db)
50.2	N/A

Efficiency				
125%	100%	75%	50%	25%
98.78	98.97	99.16	99.29	99.27

Liquid Testing		
PF	Water	Dielectric
N/A	N/A	N/A

Unit contained less than 1PPM PCB at the time of manufacture.

Pressure Test Results:
Unit Successfully Passed QC Impulse Test.
Unit was leak tested and no detectable leaks were found.

I hereby certify that this is a true report based on factory tests made in accordance with the latest IEEE/ANSI C571290 and C571200 and that each transformer withstood the insulation tests.



>c\b`K `7fchmz`D`9"
9b[]bYYf]b[`A UbU[Yf
8]grf]Vi h]cb HfUbgzcf a Yfg 8]]g]cb

**SQUARE D COMPANY
CERTIFIED TRANSFORMER TEST REPORT**

Ratio Test Results

DV Position	Tap Position	Tap	Phase A	Phase B	Phase C	Vector
	1	13094	47.23170	47.22950	47.22960	DY1
	2	12782	46.11930	46.11850	46.12140	DY1
	3	12470	45.01080	45.00950	45.01250	DY1
	4	12158	43.89970	43.89800	43.89940	DY1
	5	11846	42.73160	42.72990	42.73240	DY1

Fusing Equipment

Electrical Apparatus
240-50

ELSP Current-Limiting Backup Fuse

GENERAL

The Cooper Power Systems ELSP Current-limiting Backup Fuse is used in series with low current primary protection devices such as a Bay-O-Net Fuse or MagneX® Interrupter.

The ELSP fuse is designed for use in transformer oil, Envirotemp® FR3® fluid, or an approved equivalent.

The fuse's highly efficient current-limiting section minimizes the effects of high fault current stresses on equipment and the distribution system. Its minimum interrupting rating is coordinated with that of a low current interrupter to avoid undesirable low current operation; yet its maximum interrupting rating will clear the highest fault currents likely to occur. Higher continuous current ratings can be achieved by connecting two fuses in parallel.

APPLICATION

The ELSP fuse is used in transformers to protect and isolate faulted equipment. When connected in series with a low current primary protection device, the fuse becomes an element of a two-part protection system that gives a full range of fault protection.

This two-part system provides low current protection with the replaceable expulsion fuse or resettable MagneX Interrupter, and it adds the energy-limiting protection of a current-limiting fuse. Together, they coordinate easily with upstream and downstream devices.



Figure 1.
ELSP Current-Limiting Backup Fuse.

INSTALLATION

No special tools are required. The fuse is liquid immersed, mounted as near as possible to the incoming primary bushing to which it is connected. Normal liquid dielectric clearances should be used. Refer to Installation Instructions Sheet S240-50-1 for details.

PRODUCTION TESTS

Tests are conducted on 100 percent of production in accordance with Cooper Power Systems requirements.

- Physical Inspection
- I²t Testing
- Resistance Testing
- Helium Mass Spectrometer Leak Testing

TABLE 1
Electrical Ratings and Characteristics

Fuse Type	Maximum Interrupting Current
Backup (Partial Range) "C" Rated	50,000 A rms symmetrical*

*See Table 2 for fuses with ratings other than 50,000 A rms symmetrical

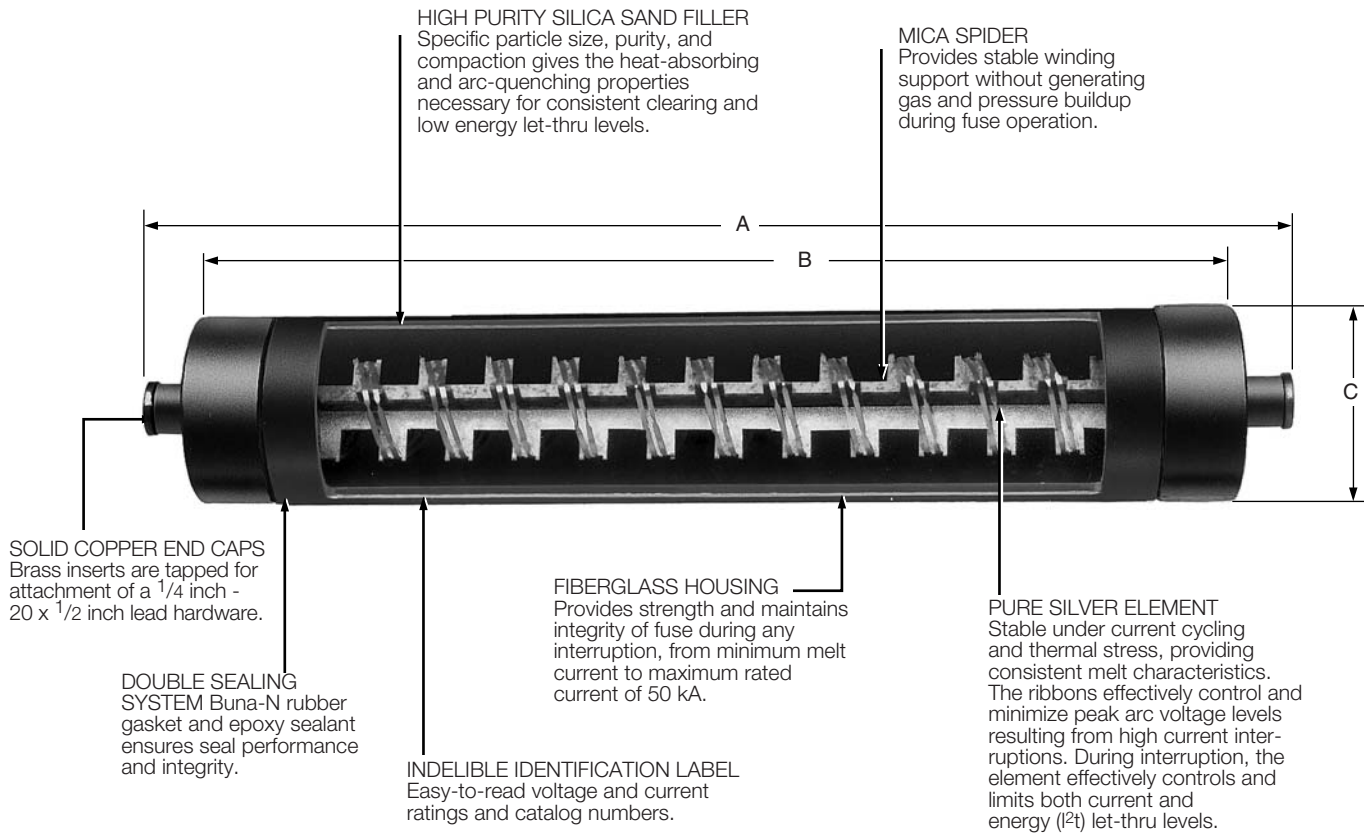

Figure 2.
2" diameter ELSP Current-Limiting Back-up Fuse cutaway shows design characteristics.

Note: Dimensions given are for reference only.

TABLE 2
Interrupting Ratings

Continuous Current Rating (A)	8.3 kV ₁			15.5 kV ₂			23 kV ₃		
	Minimum Interrupting Capacity (A)	Minimum Melt I ² t (A ² •s)	Maximum Clear I ² t (A ² •s)	Minimum Interrupting Capacity (A)	Minimum Melt I ² t (A ² •s)	Maximum Clear I ² t (A ² •s)	Minimum Interrupting Capacity (A)	Minimum Melt I ² t (A ² •s)	Maximum Clear I ² t (A ² •s)
30	100	1,200	5,800	100	1,200	7,600	125	1,200	10,500
40	125	1,800	8,200	150	1,800	11,000	200	1,800	15,100
50	165	4,100	16,500	200	4,100	23,000	325	4,100	34,300
65	300	6,200	26,700	350	6,200	33,000	400	6,200	38,400
80	200	9,600	42,900	250	9,600	52,900	300	9,600	68,300
100	350	17,100	62,000	350	17,100	93,800	400	17,100	121,000
125	375	30,500	97,800	400	30,500	125,700	500	30,500	149,700
150	450	43,900	148,000	450	43,900	162,300	600	43,900	196,700
165	500	68,600	245,000	—	—	—	700	68,600	307,300
250**	800	122,000	369,000	800	122,000	408,000	900	122,000	391,100
300**	1000	175,600	566,000	1000	175,600	660,700	1200	175,600	563,000
330**	1200	274,400	875,700	—	—	—	1400	274,400	882,000

Notes:

- The 8.3 kV, 30 A through 100 A ratings have been tested and approved for application at 9.9 kV. The maximum interrupting capacity for the 65 A through 100 A ratings at 9.9 kV is 18 kA.
 - The 15.5 kV, 30 through 125 A and 250 A ratings have been tested and approved for application at 17.2 kV. The maximum interrupting rating for the 15.5 kV fuse, 30 A through 125 A at 17.2 kV is 43 kA. For the 15 kV, 250 A fuse at 17.2 kV the maximum interrupting rating is 12 kA.
 - The maximum interrupting rating for the 23 kV fuse, 80 A through 165 A, 300 A and 330 A, is 30 kA. For the 23 kV, 250 A fuse the maximum interrupting rating is 12 kA.
- ** Parallel Fuses

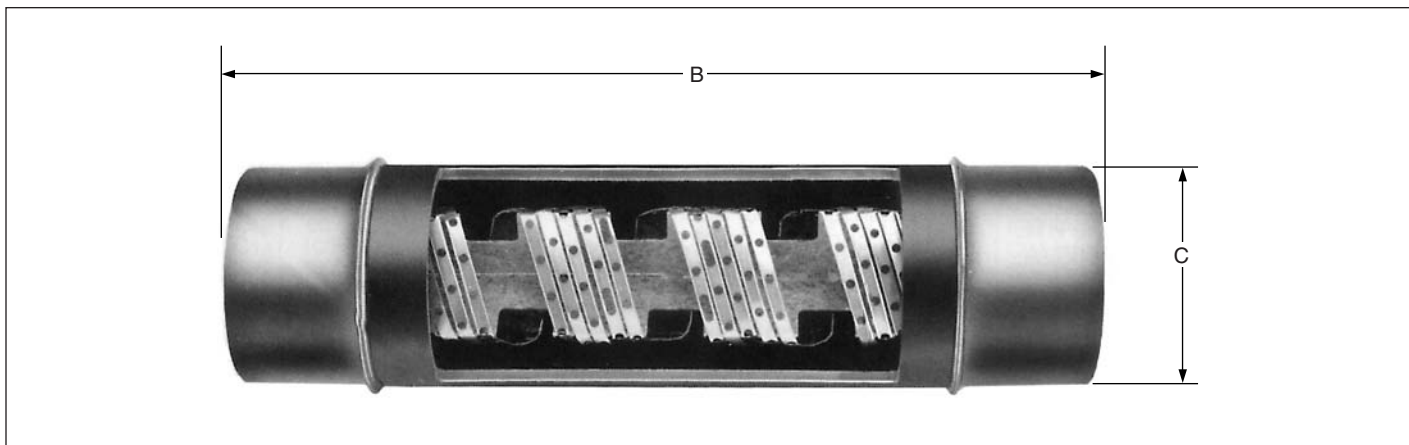

Figure 3.
3" diameter ELSP Current-Limiting Backup Fuse cutaway shows design characteristics.

Note: Dimensions given are for reference only.

TABLE 3
Dimensional Information

Voltage (kV)	Current Rating (A)	A Dim. in/ (mm)	B Dim. in/ (mm)	C Dim. in/ (mm)	Ref. Figure
8.3	30-65	7.2 (183)	6.0 (152)	2.1 (53)	2
	80-125	9.6 (244)	8.4 (214)	2.1 (53)	2
	150-165	10.9 (277)	9.7 (247)	2.1 (53)	2
15.5	30-65	9.7 (247)	8.5 (216)	2.1 (53)	2
	80-125	14.0 (356)	12.8 (325)	2.1 (53)	2
	150	16.3 (414)	15.1 (384)	2.1 (53)	2
23	30-65	12.7 (323)	11.5 (292)	2.1 (53)	2
	80-125	16.9 (429)	15.6 (396)	2.1 (53)	2
	150-165	n/a	18.9 (480)	3.0 (76)	3

ORDERING INFORMATION

To order an ELSP current-limiting fuse, determine the amperage and voltage ratings of the application and specify the fuse required from Table 4. For parallel fusing, order two fuses.

TABLE 4
ELSP Back-Up Fuse Catalog Numbers

Current Rating (A)	Catalog Number		
	8.3 kV	15.5 kV	23 kV
30	3543030M61M	3544030M61M	3545030M61M
40	3543040M61M	3544040M61M	3545040M61M
50	3543050M61M	3544050M61M	3545050M61M
65	3543065M61M	3544065M61M	3545065M61M
80	3543080M71M	3544080M71M	35475080M71M
100	3543100M71M	3544100M71M	3545100M71M
125	3543125M71M	3544125M71M	3545125M71M
150	3543150M71M	3544150M71M	3545150M71M
165	3543165M71M	N/A	3545165M71M
250*	3543125M71M	3544125M71M	3545125M71M
300*	3543150M71M	3544150M71M	3545150M71M
330*	3543165M71M	N/A	3545165M71M

* Parallel fuse application (ORDER TWO FUSES)

Method A

CORRELATION INFORMATION

Use the correlation information in Tables 5, 6 and 7 to determine the amperage and voltage ratings of the ELSP fuse combination required for the application. Then use Table 4 to determine the appropriate ELSP fuse catalog number.

Correlation is based on **IEEE Standard C57.92™** Loading Guide and **IEEE Standard C57.109™** Through-Fault Guide, and the Fuse Application Guide CP7662A.

Tables 5, 6 and 7 indicate the recommended Bay-O-Net fuse link or MagneX Interrupter and ELSP combination for each application.

To order a current sensing Bay-O-Net Fuse, complete catalog number 4000353_____.

To order a dual sensing Bay-O-Net Fuse, complete catalog number 4000358_____.

To order a dual element Bay-O-Net Fuse, complete catalog number 4038108_____.

To order a High Ampere Overload Bay-O-Net Fuse Link, complete catalog number 4038361_____.

Examples:

To order an ELSP and dual element Bay-O-Net fuse combination for a single-phase, 7.2 kV phase-to-ground, 50 kVA transformer, specify:

- 1-50 A ELSP Fuse 3543050M61M
- 1-Bay-O-Net Fuse 4038108C07

TABLE 6 (Continued)
Recommended Three-Phase Transformer Bay-O-Net and ELSP Combinations

Three-Phase Transformer (kVA)	Nominal Three-Phase Voltage (kV) Phase-to-Phase											
	12-12.47			13.2-14.4			20.8d			24.9d		
	Assumed Trans. Impedance (%)	ELSP Rating (A)	Link Cat. No.	Assumed Trans. Impedance (%)	ELSP Rating (A)	Link Cat. No.	Assumed Trans. Impedance (%)	ELSP Rating (A)	Link Cat. No.	Assumed Trans. Impedance (%)	ELSP Rating (A)	Link Cat. No.
ELSP and Current Sensing Bay-O-Net Fuse Combinations ^a												
45	1.6	30	C04	1.6	30	C04	1.6	30	C04	1.6	30	C04
75	1.6	30	C06	1.6	30	C06	1.6	30	C04	1.6	30	C04
112.5	1.8	30	C06	1.8	30	C06	1.8	30	C06	1.8	30	C04
150	2.0	40	C08	2.0	40	C08	2.0	30	C06	2.0	30	C06
225	3.0	65	C10	3.0	65	C10	3.0	30	C08	3.0	30	C06
300	3.5	65	C10	3.5	65	C10	3.5	30	C08	3.5	30	C08
500	4.0	100	C12	4.0	100	C12	4.0	65	C10	4.0	50	C10
750	5.75	125	C14	5.75	125	C14	5.75	80	C12	5.75	80	C12
1000	5.75	250	C16	5.75	125	C14	5.75	125	C14	5.75	80	C12
1500	5.75	250	C17	5.75	250	C17	5.75	125	C14	5.75	125	C14
2000	5.75	—	—	5.75	250	C17	5.75	250	C16	5.75	250	C16
ELSP and Dual Sensing Bay-O-Net Fuse Combinations ^b												
45	1.6	30	C03	1.6	30	C03	1.6	30	C03	1.6	30	C03
75	1.6	30	C05	1.6	30	C05	1.6	30	C03	1.6	30	C03
112.5	1.8	65	C08	1.8	50	C08	1.8	30	C05	1.8	30	C05
150	2.0	65	C08	2.0	65	C08	2.0	30	C05	2.0	30	C05
225	3.0	100	C10	3.0	100	C10	3.0	50	C08	3.0	50	C08
300	3.5	100	C10	3.5	100	C10	3.5	50	C08	3.5	50	C08
500	4.0	150	C12	4.0	125	C12	4.0	100	C10	4.0	100	C10
750	5.75	250	C14	5.75	250	C14	5.75	125	C12	5.75	125	C12
1000	5.75	250	C14	5.75	250	C14	5.75	125	C12	5.75	125	C12
1500	5.75	—	—	5.75	—	—	5.75	250	C14	5.75	250	C14
2000	5.75	—	—	5.75	—	—	5.75	—	—	5.75	250	C14
ELSP and Dual Element Bay-O-Net Fuse Combinations ^b												
45	1.6	30	C03	1.6	30	C03	1.6	30	C03	1.6	30	C03
75	1.6	30	C04	1.6	30	C04	1.6	30	C03	1.6	30	C03
112.5	1.8	40	C06	1.8	40	C06	1.8	30	C05	1.8	30	C04
150	2.0	50	C07	2.0	50	C07	2.0	40	C06	2.0	30	C05
225	3.0	80	C09	3.0	80	C09	3.0	50	C07	3.0	30	C06
300	3.5	80	C09	3.5	80	C09	3.5	80	C09	3.5	50	C07
500	4.0	100	C12	4.0	100	C12	4.0	80	C11	4.0	80	C09
750	5.75	125	C14	5.75	125	C14	5.75	100	C12	5.75	80	C11
1000	5.75	—	—	5.75	—	—	5.75	125	C14	5.75	100	C12
1500	5.75	—	—	5.75	—	—	5.75	—	—	5.75	—	—
2000	5.75	—	—	5.75	—	—	5.75	—	—	5.75	—	—
High Amp Overload Bay-O-Net/ELSP Combinations												
150	2.0	—	—	2.0	—	—	2.0	—	—	2.0	—	—
225	3.0	—	—	3.0	—	—	3.0	—	—	3.0	—	—
300	3.5	—	—	3.5	—	—	3.5	—	—	3.5	—	—
500	4.0	—	—	4.0	—	—	4.0	—	—	4.0	—	—
750	5.75	125	C03CB	5.75	—	—	5.75	—	—	5.75	—	—
1000	5.75	250	C04CB	5.75	125	C03CB	5.75	—	—	5.75	—	—
1500	5.75	250	C04CB**	5.75	250	C04CB	5.75	125	C03CB	5.75	125	C03CB
2000	5.75	250	C05CB***	5.75	250	C05CB	5.75	250	C04CB	5.75	250	C04CB
2500	5.75	250	C05CB***	5.75	250	C05CB***	5.75	250	C04CB**	5.75	250	C04CB

Indicates parallel fuse application

Note: Table shows minimum recommended ELSP fuse rating. Recommended ELSP backup fuse will coordinate with protecting fuse and melt only on internal transformer faults. Recommended Bay-O-Net fuses meet inrush criterion of 12 times transformer full load current for 0.1 second.

a. Current sensing Bay-O-Net fuse is selected to melt at 3 to 4 times transformer full load in 300 seconds.

b. Dual sensing and Dual element Bay-O-Net fuses are selected to limit transformer load to approximately 160% for 7 hours and 200% for 2 hours with the transformer initially carrying 75% of rated load at ambient temperature of 35°C.

c. 23 kV delta primary transformer connection.

d. Recommended fuse is limited to gnd Y/gnd Y transformer with no more than 50% delta connected secondary load and with neutral internally grounded.

Phase-to-ground rated fuses are frequently recommended for gnd Y-gnd Y connections.

** The use of these fuses will provide 175% of rated load for 2 hours and 150% of rated load for 7 hours. The use of the next larger fuse is recommended for greater overload capacity. Contact your Cooper Power Systems representative for specific overload capability.

*** The specified fuse provides slightly less than 175% of rated load for 2 hours and 150% of rated load for 7 hours. Contact your Cooper Power Systems representative for specific overload capability.

See the Following Catalog Sections for Additional Information:

- ELSP Fuse Holder — Section 240-53
- Bay-O-Net Fuse Holder Assembly — Section 240-40
- Current Sensing Bay-O-Net Fuse Link — Section 240-45
- Dual Sensing Bay-O-Net Fuse Link — Section 240-46
- Dual Element Bay-O-Net Fuse Link — Section 240-48
- High Ampere Overload Bay-O-Net Fuse Link — Section 240-49
- MagneX Interrupter — Section 240-34 (previously 800-50)

Contact your Cooper Power Systems representative for further information or other applications.

Method B

TIME CURRENT CURVES

To determine or confirm the ELSP fuse that will coordinate with upstream and downstream system requirements, use the time-current characteristic curves and specify the fuse indicated from Table 4.

For full size TCC curves R240-91-71 (8.3 kV), R240-91-72 (15.5 kV), and R240-91-73 (23.0 kV), contact your Cooper Power Systems representative.

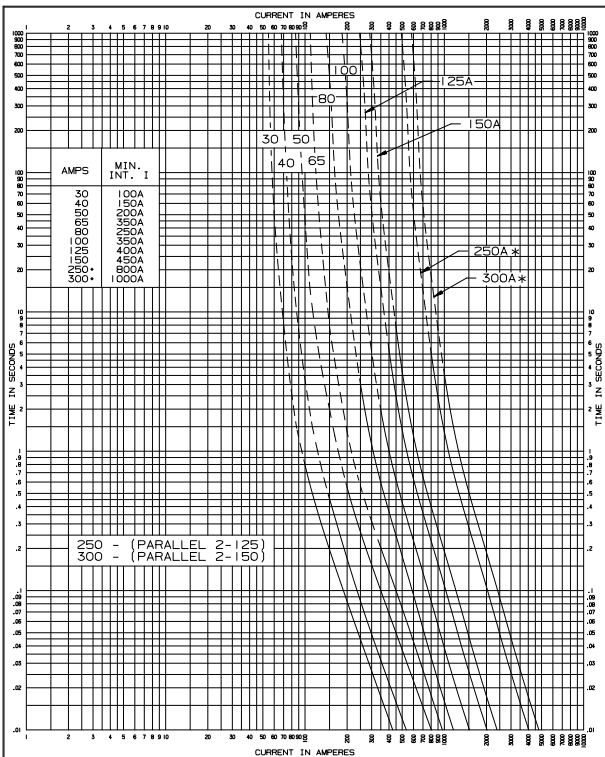



COMPONENTS AND PROTECTIVE EQUIPMENT

DATE 02/14/03 DRAWN BY ALJ
REV 01
DWG NO. 42 39732 B 00

TIME-CURRENT CHARACTERISTIC CURVES

MINIMUM MELT 15.5KV MINI-MID RANGE, AMULTI-COIL ELSP
BACKUP TYPE OIL-IMMERSIBLE CURRENT LIMITING FUSE

Tests made at LOW Volts ac at HIGH pf at 25°C with no initial load
Standards used as basis for data: ANSI C37.47-1991 (R1992)

MINIMUM TEST POINTS PLOTTED 50 VARIATIONS SHOULD BE PLUS

THIS DRAWING WAS PRODUCED ON A CAD SYSTEM, ANY MANUAL REVISION WILL VOID IT.

Reference Data
 R240-91-72
 Page 1 of 2

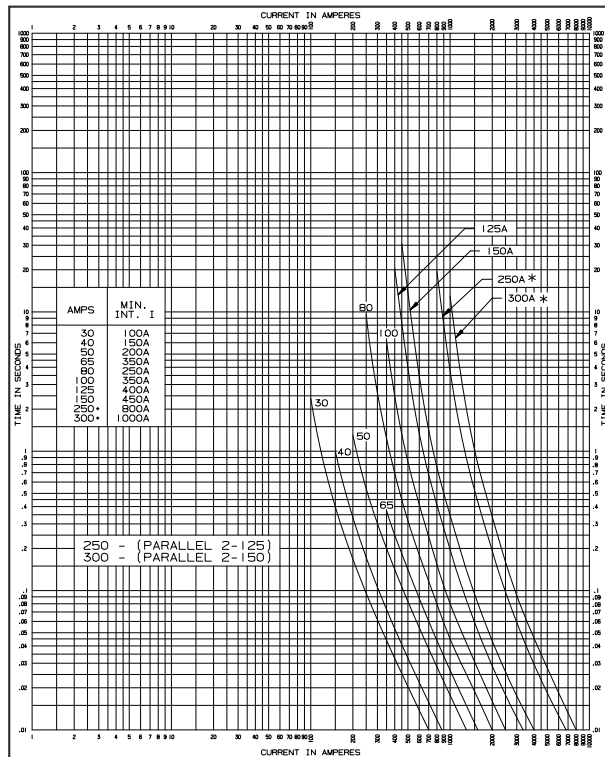



COMPONENTS AND PROTECTIVE EQUIPMENT

DATE 02/14/03 DRAWN BY ALJ
REV 01
DWG NO. 42 39732 B 00

TIME-CURRENT CHARACTERISTIC CURVES

MAXIMUM CLEAR 15.5KV MINI-MID RANGE, AMULTI-COIL ELSP
BACKUP TYPE OIL-IMMERSIBLE CURRENT LIMITING FUSE

Tests made at RATED Volts ac at LOW pf at 25°C with no initial load
Standards used as basis for data: ANSI C37.47-1991 (R1992)

MINIMUM TEST POINTS PLOTTED 50 VARIATIONS SHOULD BE MINUS

THIS DRAWING WAS PRODUCED ON A CAD SYSTEM, ANY MANUAL REVISION WILL VOID IT.

Reference Data
 R240-91-72
 Page 2 of 2

Fusing Equipment

Electrical Apparatus
240-49

High Ampere Overload Bay-O-Net Fuse Link

GENERAL

The Cooper Power Systems High Ampere Overload Bay-O-Net fuse link is used in the Cooper Power Systems silver-plated Bay-O-Net assemblies (see Section 240-40) to protect distribution apparatus from damaging currents and to protect distribution systems from failed apparatus.

High ampere overload links provide better heat dissipation when used at higher load current levels. These lower operating temperatures will extend Bay-O-Net applications to larger kVA units.

APPLICATION

High current overload Bay-O-Net fuses were designed to allow the fusing of larger kVA distribution transformers, both single-phase and three-phase.

Its ideal use is in a two-fuse protection scheme with a current-limiting backup fuse. In this arrangement, secondary faults and overload currents are cleared by the Bay-O-Net fuse, and high level faults are cleared by the current-limiting fuse. The two fuses are connected in series and are coordinated so that the current-limiting fuse operates only upon internal transformer failure (see Section 240-50 to order a Cooper Power Systems ELSP current-limiting back-up fuse). If the Bay-O-Net will not be used in series with a current-limiting fuse, an isolation link is required (see Section 240-47).

The High Ampere Overload Bay-O-Net fuse is an integrated fuse link and cartridge design specially engineered to reduce operation temperatures. The Bay-O-Net design allows the integral (link) cartridge to be easily field replaceable.

High Ampere Overload Links should only be used in silver-plated Flapper Bay-O-Net assemblies in order to ensure the intended operating characteristics.

INSTALLATION

No special tools are required. A hotstick is used to remove the Bay-O-Net fuse cartridge holder from non-pressurized apparatus. The entire fuse cartridge is then replaced. No field installation of the fuse link into the cartridge is required. The fuse



Figure 1. High Ampere Overload Bay-O-Net Fuse Link with integral cartridge.

holder is then reinstalled into the apparatus using a hotstick. Refer to Service Section S240-40-3 for refusing instruction.

ORDERING INFORMATION

To order a Cooper Power Systems High Ampere Overload Bay-O-Net Fuse Link, determine the requirements of the application from Tables 3 and 4 and specify the fuse required from Table 2.

Method A

USING THE CORRELATION TABLES

Use the following correlation information (Tables 3 and 4) to complete Catalog Number 4038361C-CB.

For single-phase and three-phase applications, a Cooper Power Systems ELSP current-limiting backup fuse is recommended (see Section 240-50 for more information).

Correlation is based on **IEEE Standard C57.92TM** Loading Guide, **IEEE Standard C57.109TM** Through-Fault Guide and Fusing Application Guide CP7662A.

TABLE 1
Electrical Ratings and Characteristics

Voltage (kV)	Maximum Single-Phase Interrupting Rating*	
	Sidewall Mount Assembly (rms symmetrical) in Mineral Oil	Sidewall Mount Assembly (rms symmetrical) in Envirotemp® FR3® Fluid
8.3	3500 A	2000 A
15.5	2500 A	2500 A
23.0	***	***

* In Cooper Power Systems Bay-O-Net assemblies only. Where available fault current exceeds rated value, coordinated current-limiting fusing, such as an ELSP (Section 240-50) or approved equivalent, must be provided.

*** Not rated for 23.0 kV

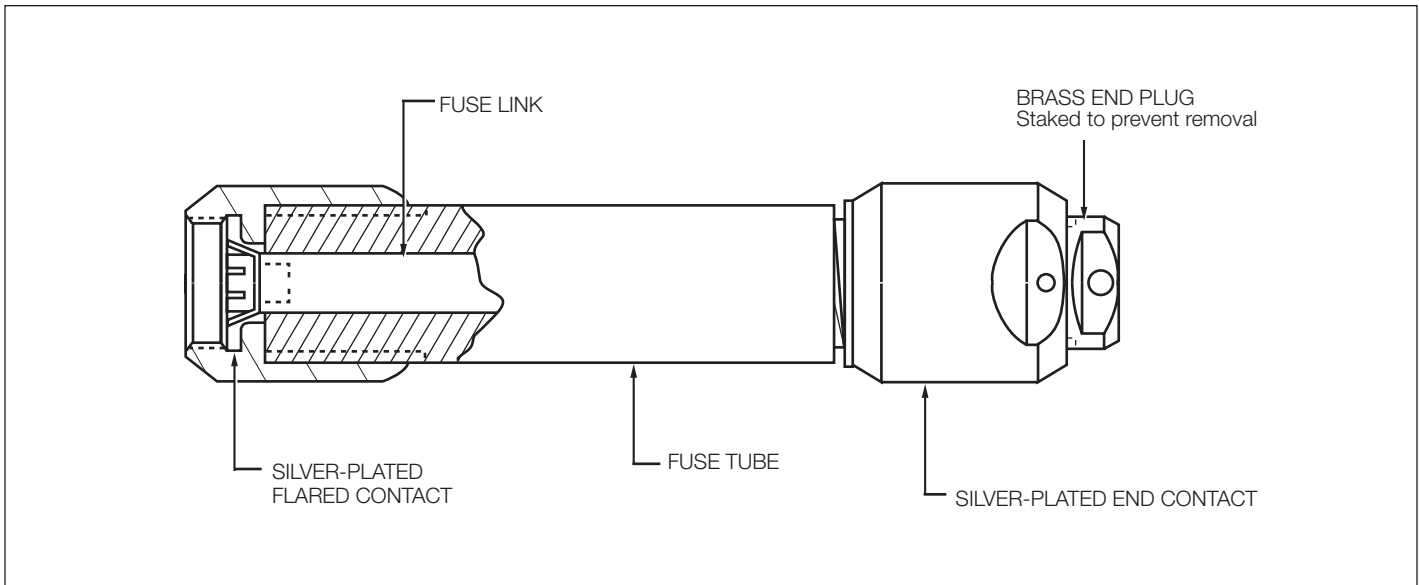

Figure 2. Cutaway drawing of High Ampere Overload Bay-O-Net Fuse Link with feature information.

TABLE 2
High Ampere Overload Bay-O-Net Fuse Link

Current Rating (A)	Continuous Current Rating at 25°C*	Catalog Number**
65	135	4038361C03CB
100	165	4038361C04CB
125	185	4038361C05CB
Shorting Bar (Solid link)	200	4038361C10CB

* For current ratings at temperatures above 25°C, refer to deration curves in Figure 3.
** Catalog number is an integral element/cartridge/end plug design.

Method B
USING TIME CURRENT CURVES

To determine or confirm the High Ampere Overload Bay-O-Net fuse that will coordinate with upstream and downstream requirements, use time-current characteristic curves and specify the fuse indicated from Table 2.

Deration curves for the High Ampere Overload Links are shown in Figure 3. Long term overload curves for selected transformer ratings are also available upon request.

For full size TCC curves R240-91-53, long term overload curves, and further information regarding either of these ordering methods, contact your Cooper Power Systems representative.

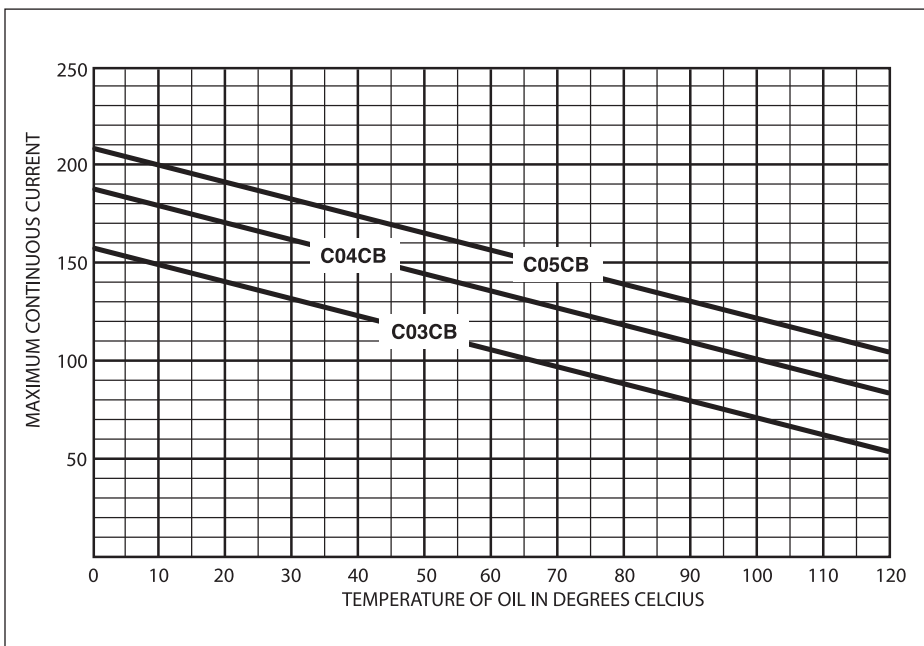

Figure 3. Deration curves for high ampere overload links.

TABLE 3
Correlation Information
Single-Phase Transformer (Phase-to-Ground) Applications

Transformer kVA	Transformer Primary Voltage (kV)										
	2.4	4.16	4.8	7.2	7.62	8.32	12.0	12.47	13.2	13.8	14.4
100	C03CB	*	*	*	*	*	*	*	*	*	*
167	C04CB**	C03CB	C03CB	*	*	*	*	*	*	*	*
250	C05CB***	C04CB	C04CB	*	*	*	*	*	*	*	*
333		C05CB	C04CB**	C03CB**	C03CB	C03CB	*	*	*	*	*
500		C05CB***	C05CB***	C04CB**	C04CB	C04CB	C03CB	C03CB	C03CB	C03CB	C03CB
833				C05CB***	C05CB***	C05CB**	C04CB**	C04CB**	C04CB	C04CB	C04CB

Notes: Coordination recommendations are based on 12X transformer full load for 0.10s, 3X transformer full load for 10s, 200% of rated load at 2 hours and 160% of rated load at 7 hours. Overload protection based on 65 degrees rise transformers per **IEEE C57.91**TM-1981.

* For additional application recommendations, refer to other Bay-O-Net link catalog sections (240-45 Current Sensing, 240-46 Dual Sensing, and 240-48 Dual Element links).

** The use of these fuses will provide 175% of rated load at 2 hours and 150% of rated load at 7 hours. The use of the next larger fuse is recommended for greater overload capacity. Contact your Cooper Power Systems representative for specific overload capability.

*** The specified fuse provides slightly less than 175% of rated load at 2 hours and 150% of rated load at 7 hours. Contact your Cooper Power Systems representative for specific overload capability.

TABLE 4
Correlation Information
Three-Phase Transformer (Phase-to-Phase) Applications

Transformer kVA	Transformer Primary Voltage (kV)											
	2.4	4.16	4.8	8.32	12.0	12.47	13.2	13.8	14.4	20.8a	22.9a	24.9a
150	C03CB	*	*	*	*	*	*	*	*	*	*	*
225	C04CB	*	*	*	*	*	*	*	*	*	*	*
300	C04CB**	C03CB	C03CB	*	*	*	*	*	*	*	*	*
500	C05CB***	C04CB**	C04CB	C03CB	*	*	*	*	*	*	*	*
750		C05CB***	C05CB	C04CB	C03CB	C03CB	*	*	*	*	*	*
1000			C05CB***	C04CB**	C04CB	C04CB	C03CB	C03CB	C03CB	*	*	*
1500				C05CB***	C04CB**	C04CB**	C04CB	C04CB	C04CB	C03CB	C03CB	C03CB
2000					C05CB***	C05CB***	C05CB	C05CB	C05CB	C04CB	C04CB	C04CB
2500					C05CB***	C05CB***	C05CB***	C05CB***	C05CB***	C04CB**	C04CB	C04CB

Notes: Coordination recommendations are based on 12X transformer full load for 0.10s, 3X transformer full load for 10s, 200% of rated load at 2 hours and 160% of rated load at 7 hours. Overload protection based on 65 degrees rise transformers per **IEEE C57.91**TM-1981.

a. Recommended fuse is limited to gndY/gndY transformer with less than 50% delta loading.

* For additional application recommendations, refer to other Bay-O-Net link catalog sections (240-45 Current Sensing, 240-46 Dual Sensing, and 240-48 Dual Element links).

** The use of these fuses will provide 175% of rated load at 2 hours and 150% of rated load at 7 hours. The use of the next larger fuse is recommended for greater overload capacity. Contact your Cooper Power Systems representative for specific overload capability.

*** The specified fuse provides slightly less than 175% of rated load at 2 hours and 150% of rated load at 7 hours. Contact your Cooper Power Systems representative for specific overload capability.

© 2006 Cooper Power Systems, Inc., or its affiliates.
Envirotemp® and FR3 are registered trademarks of Cooper Power Systems, Inc., or its affiliates.
IEEE Standard C57.92™, IEEE Standard C57.109™, IEEE Standard C57.91 and IEEE Standard C57.91™ are trademarks of the Institute of Electrical and Electronics Engineers, Inc.



1045 Hickory Street
Pewaukee, WI 53072 USA
www.cooperpower.com

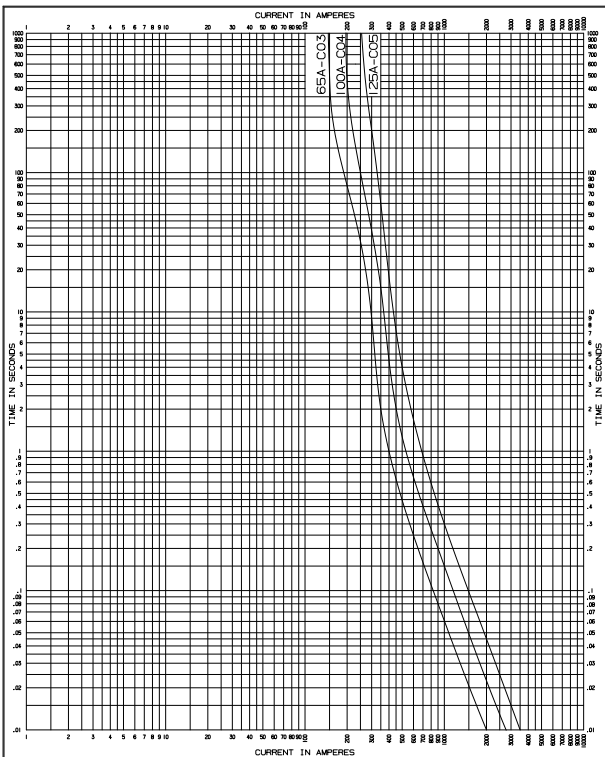

TIME-CURRENT CHARACTERISTIC CURVES

MINIMUM MELT
HIGH AMP TRANSFORMER OVERLOAD LINK (65, 100, 125A)

Tests made at LOW Volts ac at HIGH pf at 25°C with no initial load

Standards used as basis for data: ANSI C37.47-1981

MINIMUM TEST POINTS PLOTTED SO VARIATIONS SHOULD BE PLUS

THIS DRAWING WAS PRODUCED ON A CAD SYSTEM, ANY MANUAL REVISION WILL VOID IT.

Reference Data
R240-91-53
Page 1 of 2

COOPER
COOPER POWER SYSTEMS DIVISION
COMPONENTS & PROTECTIVE EQUIPMENT

DRAWN BY: EKS
DATE: 06-07-00
REPLACES: 07/97/REV 03
DWG NO.: 42 39326 B 00

CHKD: []
REV 03
REG NO. 19793

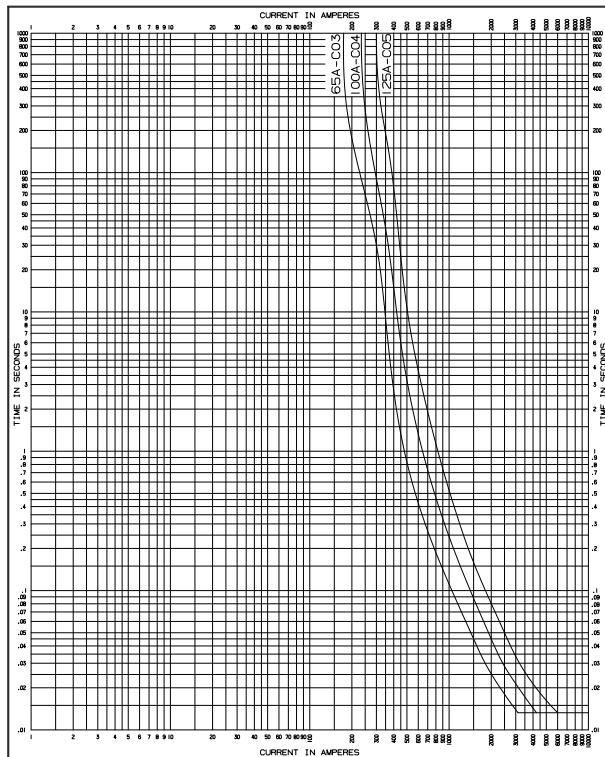

TIME-CURRENT CHARACTERISTIC CURVES

MAXIMUM CLEAR
HIGH AMP TRANSFORMER OVERLOAD LINK (65, 100, 125A)

Tests made at RATED Volts ac at LOW pf at 25°C with no initial load

Standards used as basis for data: ANSI C37.47-1981

MINIMUM TEST POINTS PLOTTED SO VARIATIONS SHOULD BE MINUS

THIS DRAWING WAS PRODUCED ON A CAD SYSTEM, ANY MANUAL REVISION WILL VOID IT.

Reference Data
R240-91-53
Page 2 of 2

COOPER
COOPER POWER SYSTEMS DIVISION
COMPONENTS & PROTECTIVE EQUIPMENT

DRAWN BY: EKS
DATE: 06-07-00
REPLACES: 07/97/REV 03
DWG NO.: 42 39326 B 00

CHKD: []
REV 03
REG NO. 19793

Fusing Equipment

Electrical Apparatus-
240-45

Current Sensing Bay-O-Net Fuse Link

GENERAL

The Cooper Power Systems Current Sensing Bay-O-Net fuse link is used in Cooper Power Systems Bay-O-Net fuse assemblies (see Section 240-40) to protect distribution apparatus from damaging currents and to protect distribution systems from failed apparatus. They are used on single-phase conventional and self-protected distribution transformers and other apparatus rated through 500 kVA, and on three-phase equipment through 1500 kVA.

A Bay-O-Net fuse is ideal for use in a two-fuse protection scheme with a current-limiting backup fuse. In this arrangement, secondary faults and overload currents are cleared by the Bay-O-Net fuse, and high level faults are cleared by the current-limiting fuse. The two fuses are connected in series, and are coordinated so that the current-limiting fuse operates only upon internal equipment failure. (See Section 240-50 to order an ELSP current-limiting backup fuse.) If the Bay-O-Net fuse will not be used in series with a current-limiting fuse, an isolation link is required. (See Section 240-47.)

Bay-O-Net fuses are comparable in cost to internal cartridge fuses but have the advantages of being field-replaceable. Bay-O-Net fuses can easily be coordinated with upstream devices.

INSTALLATION

No special tools are required. A hotstick is used to remove the Bay-O-Net fuse cartridge holder from non-pressurized apparatus. The fuse cartridge is then replaced, and the holder reinserted using a hotstick. Refer to Service Section S240-40-3 (5000023080) for re-fusing instructions.



Figure 1.
Bay-O-Net Fuse Link with contacts.

TABLE 1
Electrical Ratings and Characteristics

Voltage (kV)	Catalog Number	Maximum Single-Phase Interrupting Rating*		
		Cover Mount Assembly (rms asymmetrical) in Mineral Oil	Sidewall Mount Assembly (rms symmetrical) in Mineral Oil	Sidewall Mount Assembly (rms symmetrical) in Envirotemp® FR3™ Fluid
8.3	353C04-C08	3000 A	3500 A	3500 A
	353C10-C12	3000 A	3500 A	2500 A
	353C14-C17	3000 A	3500 A	2500 A
15.5	353C04-C08	1800 A	2500 A	2500 A
	353C10-C12	1800 A	2500 A	1500 A
	353C14-C17	1800 A	2500 A	2500 A
23.0	353C04-C17	600 A	1000 A	1000 A

* In Cooper Power Systems Bay-O-Net assemblies only. Where available fault current exceeds rated value, coordinated current-limiting fusing such as an ELSP (Section 240-50) or approved equivalent must be provided.

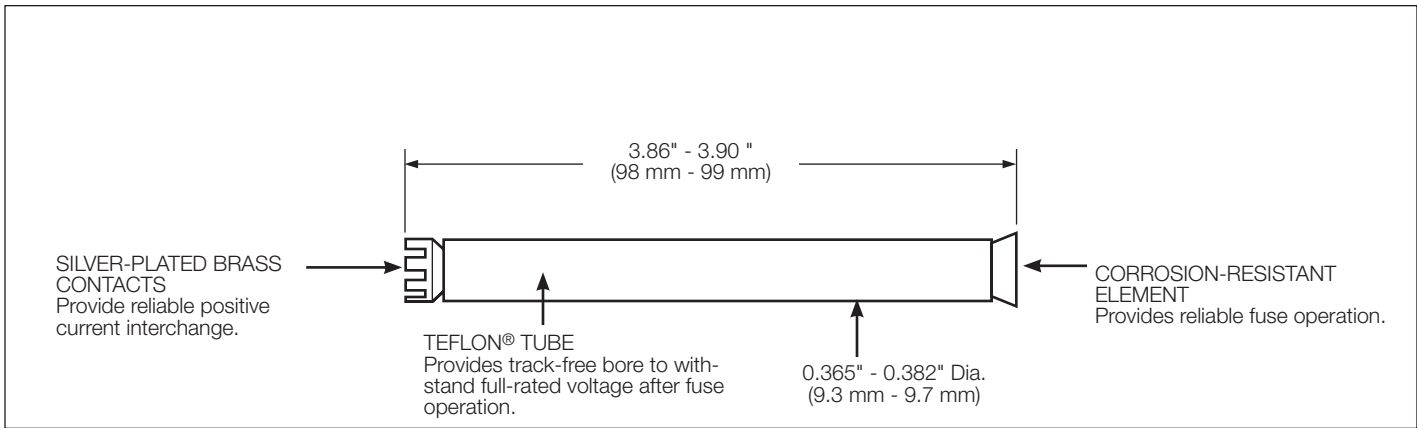

Figure 2.
Fuse Link features and dimensional information.

Note: Dimensions given are for reference only.

ORDERING INFORMATION

To order a current sensing Bay-O-Net fuse link, determine the requirements of the application from Tables 3 and 4 and specify the fuse required from Table 2.

TABLE 2
Bay-O-Net Fuse Link

Continuous Current Rating (A)	Catalog Number*
6	4000353C04
10	4000353C06
15	4000353C08
25	4000353C10
40	4000353C12
65	4000353C14
100	4000353C16
140	4000353C17



* Add suffix "B" to order individual fuse; add "M" to order bag of 50.

METHOD A**Using the Correlation Charts**

Use Tables 3 and 4 to complete catalog number 4000353__. For 19.9 kV single-phase and 34.5 kV three-phase applications, an ELSP current-limiting backup fuse is recommended. (See Section 240-50 for more information).

If the Bay-O-Net link is not used with a current-limiting fuse, an isolation link is required. (See Section 240-47).

Correlation is based on **IEEE Standard C57.92™** Loading Guide, **IEEE Standard C57.109™** Through-Fault Guide, and Fusing Application Guide CP7662A.

METHOD B**Using Time Current Curves**

To determine or confirm the current sensing Bay-O-Net fuse that will coordinate with upstream and downstream system requirements, use time-current characteristic curves and specify the fuse indicated from Table 2.

For full size TCC curves R240-91-50, contact your Cooper Power Systems representative.

TABLE 3
Single-Phase Transformer (Phase-to-Ground) Applications^a

Transformer kVA	Transformer Primary Voltage (kV)										
	2.4	4.16	4.8	7.2	7.62	8.32	12.0	12.47	13.2	13.8	14.4
10	C06*	C04*	C04*	C04*	C04*	C04*	C04*	C04*	C04*	C04*	C04*
15	C08*	C06*	C06*	C04*	C04*	C04*	C04*	C04*	C04*	C04*	C04*
25	C10*	C08*	C06	C06*	C04*	C04*	C04*	C04*	C04*	C04*	C04*
37.5	C10	C08	C08	C06	C06	C06	C06*	C06*	C04*	C04*	C04*
50	C12	C10	C10*	C08*	C08*	C08*	C06*	C06*	C06*	C06*	C06*
75	C14*	C12*	C10	C10*	C08*	C08*	C08*	C08*	C08*	C06	C06
100	C14	C12	C12	C10	C10	C10	C08	C08	C08	C08	C08*
167	C17*	C14*	C14*	C12	C12	C12	C10	C10	C10	C10	C10
250	–	C16	C16*	C14*	C14*	C14*	C12	C12	C12	C12*	C12*
333	–	C17*	C17*	C16*	C14	C14*	C14*	C12	C12	C12	C12
500	–	–	–	C17*	C17*	C16	C14	C14*	C14*	C14*	C14*

TABLE 4
Three-Phase Transformer (Phase-to-Phase) Applications^a

Transformer kVA	Transformer Primary Voltage (kV)									
	2.4	4.16	4.8	8.32	12.0, 12.47	13.2	13.8, 14.4	20.8 ^{b,c}	22.9 ^{b,c}	24.94 ^b
45	C10*	C08*	C06	C06*	C04*	C04*	C04*	C04*	C04*	C04*
75	C12*	C10*	C08	C06	C06*	C06*	C06*	C04*	C04*	C04
112.5	C12	C10	C10	C08	C06	C06	C06	C06*	C04*	C04
150	C14*	C12	C12*	C10*	C08*	C08*	C08*	C06*	C06*	C06
225	C16*	C14*	C12	C10	C10*	C10*	C08	C08*	C08*	C06
300	C17*	C14	C14*	C12	C10	C10	C10	C08	C08	C08
500	–	C17*	C16	C14*	C12	C12	C12	C10	C10	C10
750	–	–	C17	C16*	C14*	C14*	C14*	C12	C12	C12
1000	–	–	–	C17*	C16*	C14	C14	C14*	C12	C12
1500	–	–	–	–	C17*	C17*	C16	C14	C14*	C14*
2000	–	–	–	–	–	C17	C17	C16*	C16*	C16*
2500	–	–	–	–	–	–	–	C17*	C17*	C16

NOTE: Recommendations are based on fuse melting at 3 to 4 times transformer rated current at 5 minutes. Recommended fuses meet inrush current requirement of 12 times transformer rated current for 0.1 second.

* Recommended fuses provide more than 4 times transformer rated current for 5 minutes.

a. Bay-O-Net links alone should not be used at voltages greater than 17100 V for delta configurations or 24940 gnd Y/14400. For applications through 23 kV delta or 34500 gnd Y/19920, a 23 kV rated ELSP fuse (Section 240-50) is recommended in series with the Bay-O-Net link.

b. Recommended fuse is limited to gnd Y/gnd Y transformer with less than 50% delta loading.

c. For voltages greater than 17100 V for delta configurations or 24940 gnd Y/14400 and through 23 kV delta or 34500 gnd Y/19920, an ELSP 23 kV rated current-limiting back-up fuse (Section 240-50) in series with the Bay-O-Net fuse link is recommended.



© 2006 Cooper Power Systems or its affiliates.
FR3™ is a trademark of Cooper Power Systems, Inc., or its affiliates.
Envirotemp® is a registered trademark of Cooper Power Systems, Inc., or its affiliates.
Teflon® is a registered trademark of E.I. du Pont de Nemours and Company.
IEEE Standard C57.92™ and C57.109™ are trademarks of the Institute of Electrical and
Electronics Engineers, Inc.

1045 Hickory Street
Pewaukee, WI 53072
www.cooperpower.com

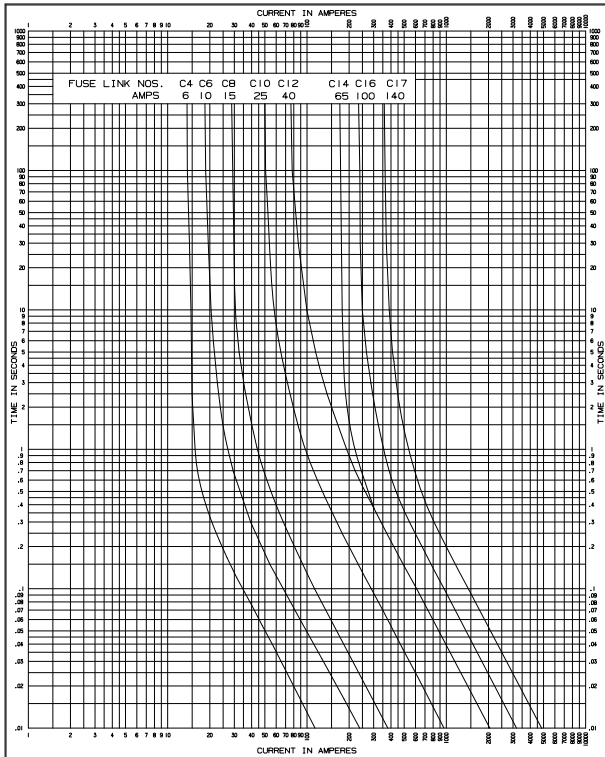

COOPER Power Systems
COMPONENTS AND PROTECTIVE EQUIPMENT

TIME-CURRENT CHARACTERISTIC CURVES
MINIMUM MELT BAY-O-NET CURRENT (FAULT) SENSING
353C FUSE LINKS IN TRANSFORMER OIL

DRAWN BY: BKS CHK'D: _____
DATE: 07-16-97 DATE: _____
REPLACES: 11/92/REV 01/REG NO. 17661
DWG NO.: 42 01553 B 00

Tests made at LOW Volts ac at HIGH pf at 25°C with no initial load
Standards used as basis for data: ANSI C37.47-1991 [R1992]
MINIMUM TEST POINTS PLOTTED SO VARIATIONS SHOULD BE PLUS
THIS DRAWING WAS PRODUCED ON A CAD SYSTEM, ANY MANUAL REVISION WILL VOID IT.

Reference Data
R240-91-50
Page 1 of 2

0, 0
R240-91-50

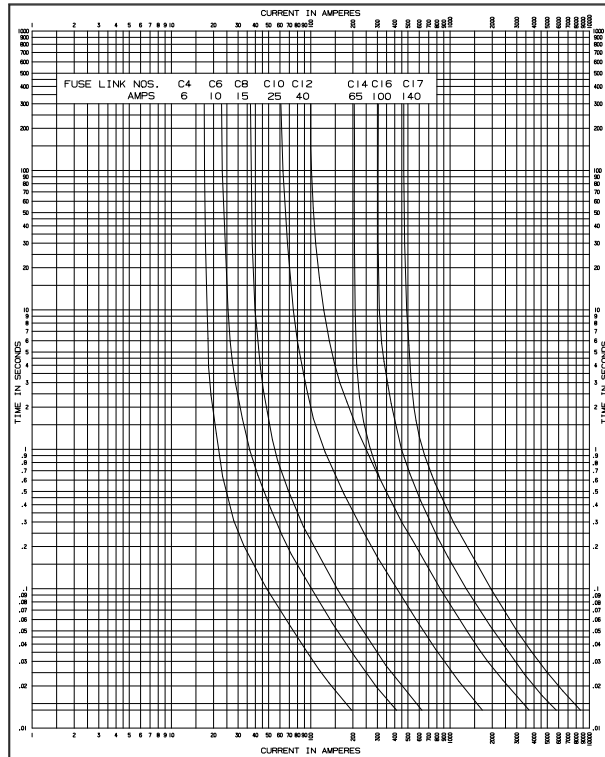

COOPER Power Systems
COMPONENTS AND PROTECTIVE EQUIPMENT

TIME-CURRENT CHARACTERISTIC CURVES
MAXIMUM CLEAR BAY-O-NET CURRENT (FAULT) SENSING
353C FUSE LINKS IN TRANSFORMER OIL

DRAWN BY: BKS CHK'D: _____
DATE: 07-16-97 DATE: _____
REPLACES: 11/92/REV 01/REG NO. 17661
DWG NO.: 42 01553 B 00

Tests made at RATED Volts ac at LOW pf at 25°C with no initial load
Standards used as basis for data: ANSI C37.47-1991 [R1992]
MAXIMUM TEST POINTS PLOTTED SO VARIATIONS SHOULD BE MINUS
THIS DRAWING WAS PRODUCED ON A CAD SYSTEM, ANY MANUAL REVISION WILL VOID IT.

Reference Data
R240-91-50
Page 2 of 2

13, 0
R240-91-50

Metal Oxide Varistor Elbow (M.O.V.E.) Surge Arrester

Electrical Apparatus
235-65

GENERAL

The M.O.V.E. Surge Arrester combines metal (zinc) oxide varistor technology in a premolded rubber elbow to provide overvoltage system protection in an insulated, fully shielded, submersible, deadfront device.

The arrester housing interface conforms to **IEEE Standard 386™** — Separable Insulated Connector Systems. The arrester housing is molded of EPDM insulating rubber, which provides deadfront safety in a small, hotstick operable unit.

M.O.V.E. Arresters are used on underground systems in pad-mounted transformer and entry cabinets, vaults, switching enclosures and other installations to provide shielded deadfront arrester protection. They are designed for use with 200 A loadbreak interfaces that conform to **IEEE Standard 386™** to limit overvoltages to acceptable levels, protect equipment and extend cable life.

CONSTRUCTION

The rubber body is constructed of high quality precision molded peroxide-cured EPDM insulation and semi-conductive materials.

The copper alloy probe and probe retainer are connected to the MOV block stack via welded flexible tin-plated copper leads. This ensures that the column cannot be damaged during installation and that a reliable current path to the MOV blocks is maintained. The disk column is composed of MOV disks bonded together with high-conductivity, silver-loaded epoxy to yield the most reliable electrical connection and eliminate air voids. The #4 AWG flexible copper ground lead, which reliably carries current to ground during voltage surges, is attached to the housing by a brass magneformed end cap. The brass end cap provides a tight, weatherproof seal.

OPERATION

Installing a M.O.V.E. Arrester at the end of a radial system or at both ends of an open point on a loop system provides excellent overvoltage protection. The addition of a second M.O.V.E. Arrester at the mid-point on a rotatable feedthru insert provides optimum protection.



Figure 1.
M.O.V.E. Surge Arresters shown from left to right: 35 kV, 25 kV and 15 kV.

600 A feeder circuits can be protected with elbow arresters installed on the Cooper T-OP II Separable Connector Systems.

STANDARDS

The M.O.V.E. Arrester complies with the latest revisions of **IEEE Standard C62.11™** "IEEE Standard for Metal Oxide Surge Arresters for AC Power Circuits" and **IEEE Standard 386™** "Separable Insulated Connectors for Power Distribution Systems Above 600 Volts."

INSTALLATION

All Cooper M.O.V.E. Arresters can be installed or removed from energized bushings with a hotstick. No special tools are required. The arrester is placed on a 200 A interface by using a hotstick. Refer to Installation Instruction Sheet S235-55-1 for more details.

PRODUCTION TESTS

Tests conducted in accordance with **IEEE Standard 386™**:

- Corona Extinction Voltage Level
- AC 60 Hz 1 Minute Withstand

Tests conducted in accordance with Cooper Power Systems requirements:

- Physical Inspection
- Periodic Dissection
- MOV Blocks:
 - Voltage at 1 mA
 - Batch Life Test
- Arrester Assembly:
 - Voltage at 1 mA
- Periodic X-ray Analysis

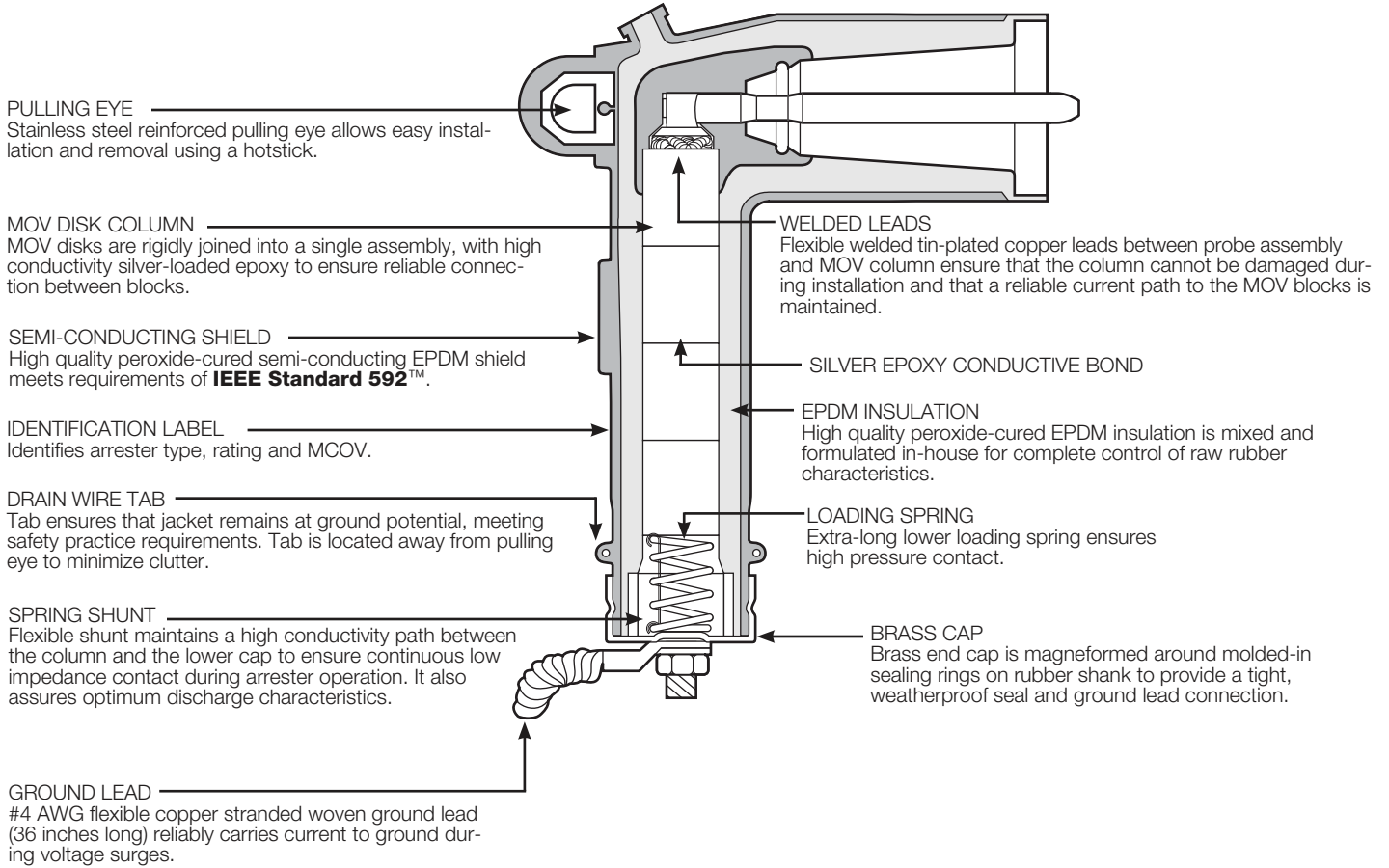

Figure 2. Cutaway illustration shows 25 kV Class Metal Oxide Varistor Elbow Surge Arrester.

PROTECTIVE CHARACTERISTICS

The protective characteristics of the M.O.V.E. Surge Arresters are shown in Table 1.

TABLE 1
Electrical Ratings and Characteristics

Duty Cycle Voltage Rating (kV)	MCOV (kV)	Equivalent Front-of-Wave (kV crest)*	Maximum Discharge Voltage (kV crest) 8/20 μ s Current Wave				
			1.5 kA	3 kA	5 kA	10 kA	20 kA
3	2.55	13.7	10.7	12.0	12.8	13.4	15.7
6	5.1	27.4	21.9	24.5	26.2	28.6	34.9
9	7.65	37.4	27.4	29.9	31.4	34.7	38.4
10	8.4	39.7	28.4	30.6	32.9	36.7	40.4
12	10.2	56.1	41.1	44.8	47.1	52.0	57.6
15	12.7	63.0	45.0	49.2	52.5	57.8	66.0
18	15.3	74.8	54.7	59.7	62.7	69.3	76.8
21	17.0	81.7	58.7	64.2	68.2	75.2	85.2
24	19.5	95.8	69.7	76.1	80.2	88.6	98.8
27	22.0	105.0	75.0	82.0	87.4	96.2	110.0
30	24.4	112.0	79.5	85.7	91.8	100.0	115.0

* Equivalent front-of-wave voltage is the expected discharge voltage of the arrester when tested with a 5 kA current surge cresting in 0.5 μ s.

TEMPORARY OVERVOLTAGE (TOV) CAPABILITY

The Temporary Overvoltage (TOV) capability of the M.O.V.E. Arrester is shown in Figure 3.

PERFORMANCE TEST CHARACTERISTICS

The M.O.V.E. Surge Arrester consistently withstands the following design tests as described by **IEEE Standard C62.11™**:

- **Duty Cycle:**
22 current surges of 5 kA crest
8/20 μs waveshape.
- **High-Current, Short-Duration Discharge:**
2 current surges of 40 kA crest
4/10 μs waveshape.
- **Low-Current, Long-Duration Discharge:**
20 current surges of 75 A crest
2000 μs rectangular wave duration.

Following each of these tests, the arresters remain thermally stable as verified by:

- Continually decreasing power values during a thirty minute power monitoring period.
- No evidence of physical or electrical deterioration.

STANDARDS

The M.O.V.E. Surge Arrester complies with the latest revision of **IEEE Standard C62.11™** "IEEE Standard for Metal Oxide Surge Arresters for AC Power Circuits" and **IEEE Standard 386™** "Separable Insulated Connectors for Power Distribution Systems Above 600 Volts."

TABLE 2
Commonly Applied Voltage Ratings of M.O.V.E. Surge Arrester

System Voltage (V rms)		Commonly Applied Arrester Duty-cycle (MCOV) Voltage Rating (kV rms) on Distribution Systems		
Nominal Voltage	Maximum Voltage range B	4-Wire Multigrounded Neutral Wye	3-Wire Low Impedance Grounded	Delta and 3-Wire High Impedance Grounded
2400	2540	—	—	3 (2.55)
4160 Y/2400	4400 Y/2540	3 (2.55)	6 (5.1)	6 (5.1)
4260	4400	—	—	6 (5.1)
4800	5080	—	—	6 (5.1)
6900	7260	—	—	9 (7.65)
8320 Y/4800	8800 Y/5080	6 (5.1)	9 (7.65)	—
12000 Y/6930	12700 Y/7330	9 (7.65)	12 (10.2)	—
12470 Y/7200	13200 Y/7620	9 (7.65) or 10 (8.4)	15 (12.7)	—
13200 Y/7620	13970 Y/8070	10 (8.4)	15 (12.7)	—
13800 Y/7970	14520 Y/8388	10 (8.4) and 12 (10.2)	15 (12.7)	—
13800	14520	—	—	18 (15.3)
20780 Y/12000	22000 Y/12700	15 (12.7)	21 (17.0)	—
22860 Y/12000	22000 Y/12700	15 (12.7)	21 (17.0)	—
23000	24340	—	—	30 (24.4)
24940 Y/14400	26400 Y/15240	18 (15.3)	27 (22.0)	—
27600 Y/15935	29255 Y/16890	21 (17.0)	30 (24.4)	—
34500 Y/19920	36510 Y/21080	27 (22.0)	—	—

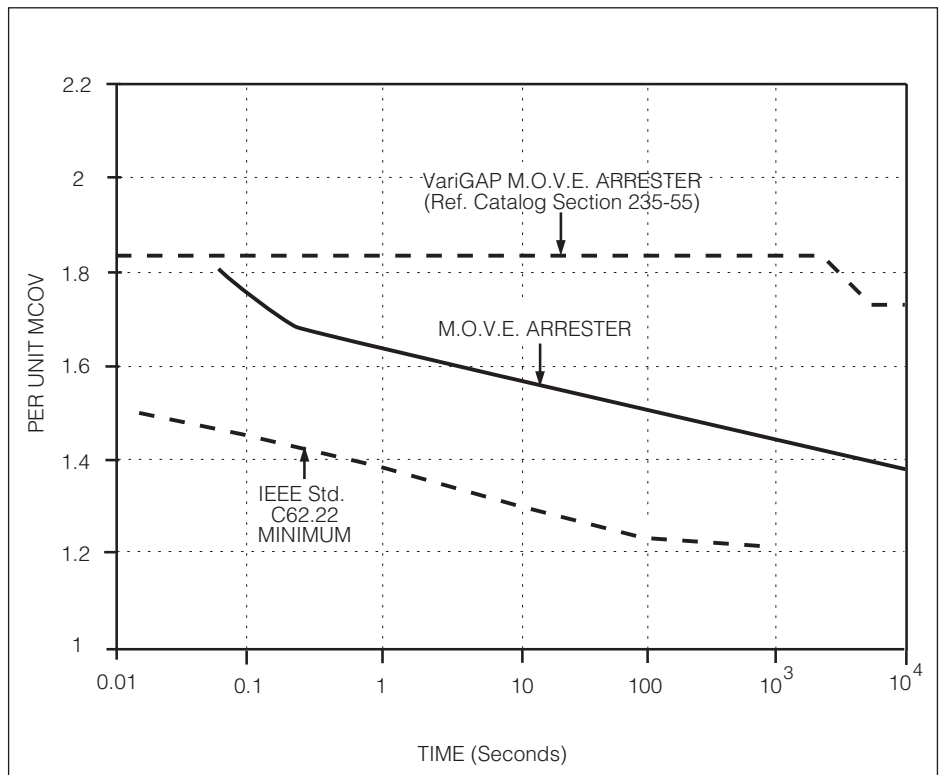

Figure 3.
Temporary overvoltage curve. No prior duty at 85° C ambient.

ORDERING INFORMATION

To order a M.O.V.E. Surge Arrester kit, determine the arrester Maximum Continuous Operating Voltage (MCOV) rating for the intended application using Table 2 and specify the appropriate catalog number from Table 3. Contact the Cooper Power Systems sales engineer in your location for applications not listed.

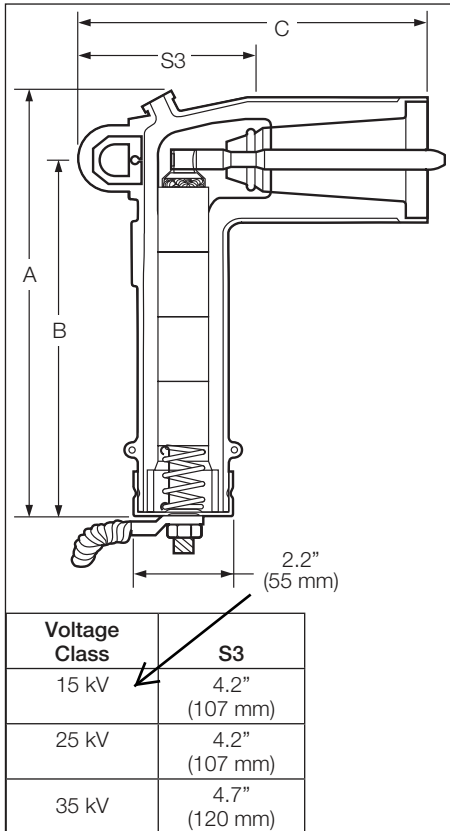

Figure 4. Dimensional information of M.O.V.E. Arrester (refer to Table 3).

Note: Dimensions given are for reference only.

TABLE 3
M.O.V.E. Surge Arrester Selection Chart

IEEE Standard 386™ Interface	Duty Cycle (kV)	MCOV Rating (kV)	Dimensions in./(mm)			Catalog Number
			A	B	C	
15 kV Class	3	2.55	8.5 (216)	7.0 (178)	7.9 (201)	3238018C03M
	6	5.1	8.5 (216)	7.0 (178)	7.9 (201)	3238018C06M
	9	7.65	8.5 (216)	7.0 (178)	7.9 (201)	3238018C09M
	10	8.4	8.5 (216)	7.0 (178)	7.9 (201)	3238018C10M
	12	10.2	8.5 (216)	7.0 (178)	7.9 (201)	3238018C12M
	15	12.7	8.5 (216)	7.0 (178)	7.9 (201)	3238018C15M
25 kV Class	18	15.3	8.5 (216)	7.0 (178)	7.9 (201)	3238018C18M
	9	7.65	8.5 (216)	7.0 (178)	7.9 (201)	3238019C09M
	10	8.4	8.5 (216)	7.0 (178)	7.9 (201)	3238019C10M
	12	10.2	8.5 (216)	7.0 (178)	7.9 (201)	3238019C12M
	15	12.7	8.5 (216)	7.0 (178)	7.9 (201)	3238019C15M
	18	15.3	8.5 (216)	7.0 (178)	7.9 (201)	3238019C18M
35 kV Class Interface 1A Large Interface	21	17.0	8.5 (216)	7.0 (178)	7.9 (201)	3238019C21M
	18	15.3	13.3 (338)	11.2 (284)	10.4 (264)	3238020C18M
	21	17.0	13.3 (338)	11.2 (284)	10.4 (264)	3238020C21M
	24	19.5	13.3 (338)	11.2 (284)	10.4 (264)	3238020C24M
	27	22.0	13.3 (338)	11.2 (284)	10.4 (264)	3238020C27M
	30	24.4	13.3 (338)	11.2 (284)	10.4 (264)	3238020C30M

ADDITIONAL INFORMATION

Refer to the following reference literature for additional information:

- 500-13, 200 A 15 kV Class Loadbreak Rotatable Feedthru Insert Catalog Section
- 500-30, 200 A 25 kV Class Rotatable Feedthru Insert Catalog Section
- 600-12, 600 A 15 kV Class T-OP II Deadbreak Connector Catalog Section

- 600-32, 600 A 25 kV Class T-OP II Deadbreak Connector Catalog Section
- 600-51, 600 A 35 kV Class T-OP II Deadbreak Connector Catalog Section

