



Powering Business Worldwide

EATON

Powering Business Worldwide



Powering Business Worldwide

Visit our Web Site <http://www.eatonelectrical.com> to view the on-line catalog, pricing, document support, distribution directory, news and events.

For warranty support

877-ETNCARE

**For a general directory
of Eaton Electrical products**

(800) 525-2000

**For on-site field service,
commissioning & maintenance**

(800) 498-2678



Powering Business Worldwide

EATON

Powering Business Worldwide



Detail Bill of Material

Project Name: City of Wichita-Water Plant 2 / UV
Lightning Protection
General Order No: SWH1180856
Negotiation No: WI830217X1K1
Alternate No: R000

Item No.	Qty	Product	Description
002	1	SURGE PROTECT & PWR COND	Eaton SPD series160kA277/480VSTD+CntrPan

Catalog No SPD160480Y3A
Product Group 39C
Designation Aftermarket SPD for PPA

Qty **List of Materials**
1 Eaton SPD series160kA277/480VSTD+CntrPan

Item No.	Qty	Product	Description
003	2	SPD	SPD

Catalog No SPD160480Y3M
Designation MCC A & C

Catalog No SPD160480Y3M
Qty **List of Materials**
1 Eaton SPD series160kA277/480VSTD+CntrNEM

Eaton Selling Policy 25-000 applies.

All orders must be released for manufacture within 90 days of date of order entry. If approval drawings are required, drawings must be returned approved for release within 60 days of mailing. If drawings are not returned accordingly, and/or if shipment is delayed for any reason, the price of the order will increase by 1.0% per month or fraction thereof for the time the shipment is delayed.

Seller shall not be responsible for any failure to perform, or delay in performance of, its obligations resulting from the COVID-19 pandemic or any future epidemic, and Buyer shall not be entitled to any damages resulting thereof.

EATON

Powering Business Worldwide

General Information: Surge Protection Device

CATALOG NUMBER:	SPD160480Y3M
DEVICE:	SPD Series
SURGE RATING:	160 kA
PER MODE SURGE RATING:	80 kA
VOLTAGE:	480 VAC
WIRING:	(4W+G)
ENCLOSURE:	NEMA 1
PROTECTION MODES:	10 Modes

<p>The information on this document is created by Eaton Corporation. It is disclosed in confidence and it is only to be used for the purpose in which it is supplied.</p>	PREPARED BY CHRIS W BROADRICK	DATE 5/26/2021	Eaton		
	APPROVED BY	DATE	JOB NAME City of Wichita-Water Plant 2 / UV Lightning Protection	DESIGNATION MCC A & C	
	VERSION 1.0.0.0	TYPE Surge Protection Device	DRAWING TYPE Final		
NEG-ALT Number WI830217X1K1-R000	REVISION 0	DWG SIZE A	G.O. SWH1180856	ITEM 003	SHEET 1 of 1

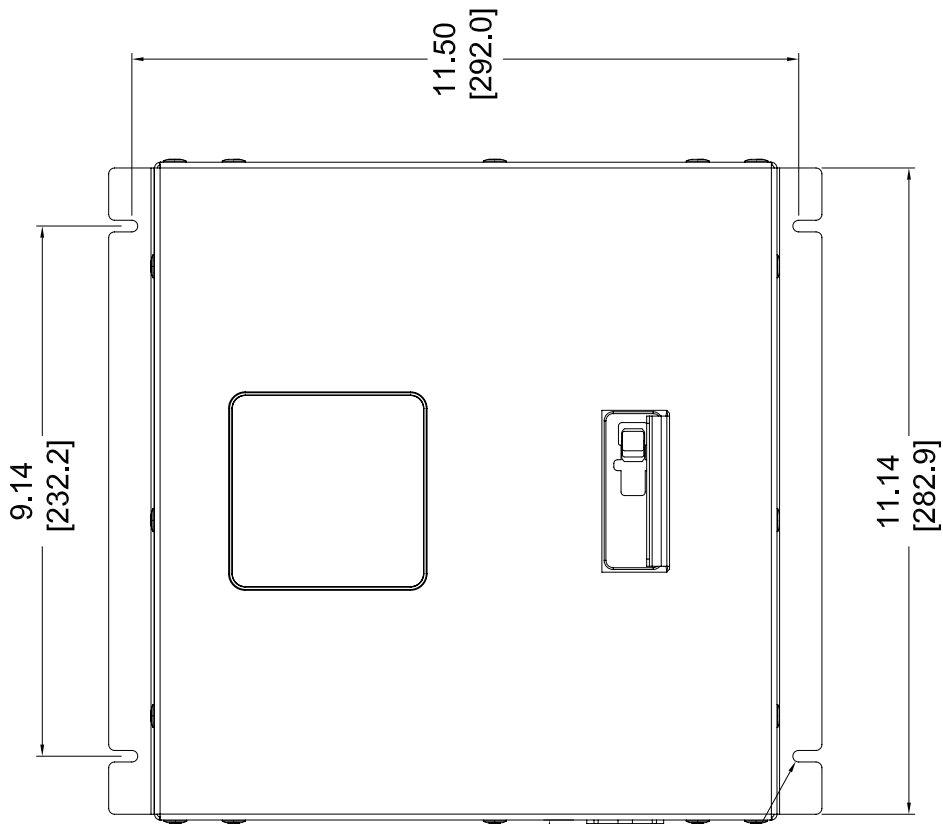

3/4" Hub
Ext Thread

0.66
[16.7]

Ø0.200
[Ø5.08]

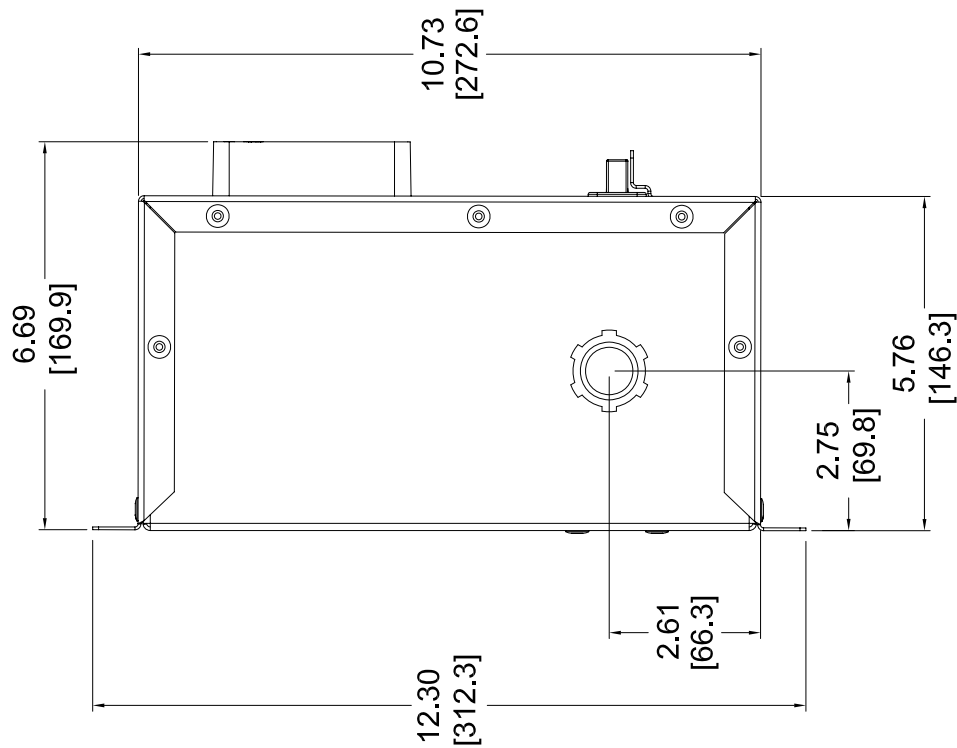

Weight - 14.7 lb / 6.7 kg

SPD SIDEMT SGL/DBL W/DISC NEMA 1
MKT-DL-10-004

GO/NEG-Alt-Date: SWH1180856-R000-5/26/2021		Job Name: City of Wichita-Water Plant 2 / UV Lightning Protection
Item Number: 003	Catalog Number: SPD160480Y3M	Designation: MCC A & C



Powering Business Worldwide

Eaton SPD Series

surge protective device

for integrated applications



For additional information on the new PX-SPD
go to www.eaton.com/pxspd

EATON

Powering Business Worldwide



Table of Contents

1.0 Introduction	1
1.1 Manual organization	1
1.2 Product overview	1
1.3 Safety precautions	1
1.4 Catalog numbering system	1
1.5 Equipment testing	2
2.0 Installation	2
2.1 Preparation for Installation	2
2.2 Installation locations	2
2.2.1 Direct bus mount applications	3
2.2.2 Connected through a circuit breaker applications	3
2.3 Installation procedures	3
2.3.1 Direct bus mount applications	3
2.3.2 Connected through a circuit breaker applications	5
3.0 Operating features	7
3.1 General	7
3.2 Displays and indicators	7
3.2.1 Basic feature package	7
3.2.2 Standard feature package	8
3.2.3 Standard With Surge Counter Feature Package	8
3.2.4 Power Xpert SPD feature package	8
4.0 Power Xpert overview	9
4.1 SPD main menu selections	9
4.1.1 SPD status	9
4.1.2 Event log	9
4.1.3 Settings	9
4.1.4 Identification	9
5.0 Power Xpert SPD user setup	10
5.1 General	10
5.2 Setup using only the local display	10
5.2.1 Configuration of the user's laptop to communicate to PX-SPD	11
5.3 Power Xpert SPD Network Connection	12
5.3.1 Establishing a secure connection	13
5.3.2 Upgrading firmware	15
5.3.4 Modbus and BACnet access	18
5.3.5 Sensitivity setting	18
5.3.6 How to reset the PX-SPD password	18
5.3.7 End of life disposal	18
6.0 SPD display rotation	20
7.0 Remote display panel (RDP) option	20
8.0 IEC approved models	20
9.0 Troubleshooting	21
10.0 Troubleshooting the Power Xpert SPD	22
11.0 Specifications	23
12.0 Ordering guidelines	25
13.0 Warranty	26
Appendix A Power Xpert SPD local display surge events menu map	27
Appendix B Power Xpert SPD local display event log menu map	27
Appendix C Power Xpert SPD local display settings menu map	28
Appendix D Power Xpert SPD local display identification menu map	29
Appendix E Power Xpert SPD local display test sequence	30
Appendix F Power Xpert SPD Modbus register map	31
Appendix G Web user error codes	35
Appendix H BACnet map	36

1.0 Introduction

1.1 Manual organization

This installation manual describes the safe installation, testing and operation of the Eaton® SPD Series surge protective device (SPD).

1.2 Product overview

The Eaton SPD Series protects critical electrical and electronic equipment from damage by power surges. This is done by shunting high energy lightning surges (and other transient disturbances) away from the equipment being protected. It does this in nanoseconds by providing a low impedance surge path to ground while supporting power frequency voltage.

The Eaton SPD Series is designed to mount on panelboards, switchgear, switchboards, busway, and motor control centers (MCCs). It is available with surge current capacity ratings from 50 to 400kA.

The Eaton SPD Series is available in four feature packages (Basic, Standard, Standard with Surge Counter, and Power Xpert SPD), as described in Section 3, "Operating features." Each model is available in delta, high leg delta, wye, single phase and split phase wiring configurations.

All Eaton SPD Series models have been tested and certified by Underwriter's Laboratory (UL®), to comply with UL 1449, 4th edition.

Eaton's One-Port low-voltage surge protective device wye models SPD120480Y2C, SPD160480Y2C, SPD200480Y2C and Delta Models SPD120480D2C, SPD160480D2C, SPD200480D2C meet the requirements of IEC 61643-11 / EN 61643-11, part 11: test class II, and are intended to be installed in indoor applications with a degree of protection rated IP 00.

1.3 Safety precautions

⚠WARNING

WARNING – SHOCK HAZARD – DO NOT OPEN. AVERTISSEMENT: RISQUE DE DECHARGE ELECTRIQUE – NE PAS OUVRIR.

WARNING NO SERVICEABLE PARTS. ATTENTION: AUCUNE PIÈCE REMPLACABLE OU RÉPARABLE

A LICENSED/QUALIFIED ELECTRICIAN MUST COMPLETE ALL INSTRUCTIONS IN THIS MANUAL IN ACCORDANCE WITH THE NATIONAL ELECTRIC CODE (NEC®), STATE, AND LOCAL CODES, OR OTHER APPLICABLE COUNTRY CODES. ALL APPLICABLE LOCAL ELECTRICAL CODES SUPERSEDE THESE INSTRUCTIONS.

CONDUCTING DIELECTRIC, MEGGAR, OR HI-POTENTIAL TESTING WITH THE SPD INSTALLED WILL CAUSE INTERNAL DAMAGE TO THE SPD. THE SPD WILL CAUSE THE TEST TO FAIL.

⚠WARNING

IMPROPER INSTALLATION COULD CAUSE DEATH, INJURY AND EQUIPMENT DAMAGE. FOLLOW ALL WARNINGS AND CAUTIONS. COMPLETELY READ AND UNDERSTAND THE INFORMATION IN THIS INSTRUCTION MANUAL BEFORE ATTEMPTING TO INSTALL OR OPERATE THIS EQUIPMENT.

ARC FLASH DURING INSTALLATION COULD CAUSE INJURY OR DEATH. USE APPROPRIATE SAFETY PRECAUTIONS, PPE AND EQUIPMENT FOR ARC FLASH PROTECTION.

INSTALLING A PROTECTION DEVICE WHICH IS UNDER RATED FOR THE ELECTRICAL SYSTEM VOLTAGE CAN CREATE A POTENTIALLY HAZARDOUS CONDITION.

CHECK THE FACILITY'S GROUNDING SYSTEM. ALL GROUNDING, BONDING AND EARTHING PRACTICES MUST MEET NEC, CEC AND LOCAL APPROVED PRACTICES. A POOR GROUND, OR A GROUNDING / BONDING VIOLATION WILL SERIOUSLY AFFECT THE SPD'S ABILITY TO FUNCTION AS SPECIFIED.

FOR USE ON CIRCUITS DELIVERING UP TO 200,000 RMS AMPS. CONVIENT À DES CIRCUITS PRODUISANT AU PLUS 200,000 A EFF.

ALWAYS VERIFY THAT NO VOLTAGE IS PRESENT BEFORE PROCEEDING WITH THE TASK AND ALWAYS FOLLOW ALL SAFETY PROCEDURES.

1.4 Catalog numbering system

Each Eaton SPD Series unit has a name plate that identifies the parameters used for manufacture. These parameters are expressed in letters and numbers to reflect the series, kA rating, voltage code, feature package, and application.

Table 1. Catalog numbering system

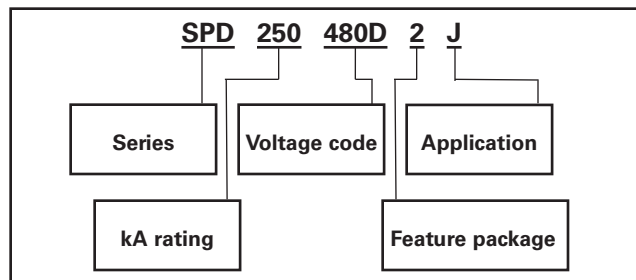

For example, a 480 volt delta (3-wire plus ground) for use in an MCC application requires an SPD model SPD 250480D2J, where:

SPD = SPD model,

250 = the kA rating (50 – 400 kA),

480D = the voltage,

2 = the feature package (Basic, Standard, Standard with Surge Counter, or Power Xpert SPD),

J = the application suffix (such as direct bus mounted in a panelboard or connected through a circuit breaker).

These numbers also appear as part of the product label attached to the front left side of the SPD. See Figure 1.

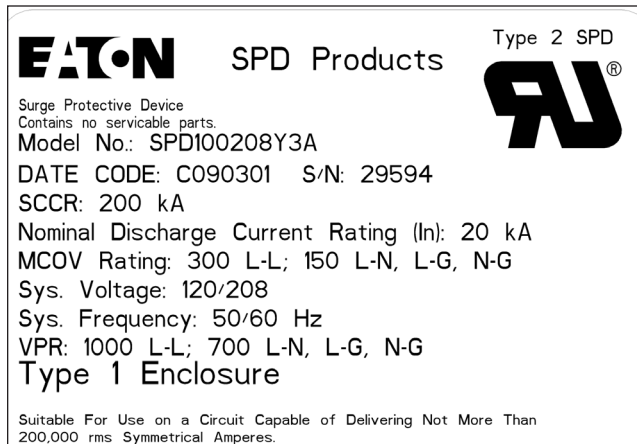

Figure 1. Product label

1.5 Equipment testing

⚠WARNING

CONDUCTING DIELECTRIC, MEGGER, OR HI-POTENTIAL TESTING WITH THE SPD INSTALLED WILL CAUSE INTERNAL DAMAGE TO THE SPD. THE SPD WILL ALSO CAUSE THE TEST TO FAIL.

Every Eaton SPD Series unit is tested at the factory for dielectric breakdown. No further SPD testing is required for installation.

If you desire to test distribution equipment by performing dielectric, megger, or hi-potential tests, any installed SPD **must** be disconnected from the power distribution system to prevent damage to the unit.

Follow this procedure to safely disconnect the SPD:

1. Remove bus connected SPDs completely from the installation prior to performing any form of hi-potential testing.
2. Isolate SPDs connected via conductors as follows:
 - a. 3-wire delta SPDs: Turn off the circuit breaker to isolate the SPD, if connected through a circuit breaker.
 - b. Wye connected SPDs: Turn off the circuit breaker **and** remove the neutral connection.
3. Remove MCC units with SPDs from the MCC structure.

2.0 Installation

⚠WARNING

INSTALLING AN SPD THAT IS IMPROPERLY RATED FOR THE ELECTRICAL SYSTEM VOLTAGE COULD CREATE A POTENTIALLY HAZARDOUS CONDITION, RESULTING IN INJURY OR EQUIPMENT DAMAGE.

2.1 Preparation for Installation

⚠CAUTION

EATON SPD SERIES PRODUCTS MUST BE INSTALLED OR REPLACED BY A QUALIFIED ELECTRICIAN TO AVOID INJURY OR EQUIPMENT DAMAGE.

Before installing an Eaton SPD Series unit, do the following:

- Verify that the area is clear of any dirt, debris or clutter that may hamper the installation process.
- Verify that there is enough space in the cabinet or MCC to install the SPD. See Section 2.3, "Installation procedures" for dimensions.
- Confirm that all tools and equipment needed for the installation are available.
- Confirm that the system voltage and wiring configuration is the same as the SPD you are installing. Check the voltage rating label on the front left side of the SPD. See Figure 1.

⚠WARNING

TURN OFF THE POWER SUPPLY BEFORE WORKING IN ANY ELECTRICAL CABINET OR ON ANY CIRCUIT BREAKER PANEL. FAILURE TO DO SO COULD RESULT IN INJURY OR DEATH FROM ELECTRICAL SHOCK.

NOTICE

A POOR GROUND, OR GROUNDING/BONDING VIOLATIONS, COULD PREVENT THE SPD FROM PERFORMING AS SPECIFIED.

DO NOT USE THE SPD TO CARRY OR PASS THROUGH GROUND TO OTHER DEVICES OR LEADS. DAMAGE TO THE EQUIPMENT MAY RESULT.

- Check the facility grounding system. All grounding, bonding, and earthing must meet the NEC, CEC and any other national, state and local electrical codes.

2.2 Installation locations

Eaton's SPD Series can be installed directly to the bus for panelboard applications.

The SPD can also be connected through a circuit breaker for installations in panelboards, switchboards, switchgear, MCC's and busway applications.

Follow these guidelines to determine the best location for mounting this product.

2.2.1 Direct bus mount applications

- Install the SPD on the load side of the main breaker. Connect the SPD directly to the bus located as close as possible to the main breaker.

2.2.2 Connected through a circuit breaker applications

- Install the SPD next to the first breaker after the incoming main lugs or main breaker.

2.3 Installation procedures

2.3.1 Direct bus mount applications

1. Verify that the SPD you are about to install is rated for the application voltage and system. See Table 9 in Section 12, "Ordering guidelines".
2. Follow all national, state and local electrical codes when connecting the SPD.
3. Before mounting the SPD, first determine the bus bar configuration. If the panelboard uses an offset B-Phase bus bar configuration, no action is required. If the panelboard uses a coplanar bus bar configuration, remove the bus bar extension bushing from the back of the SPD and discard. See Figure 2.

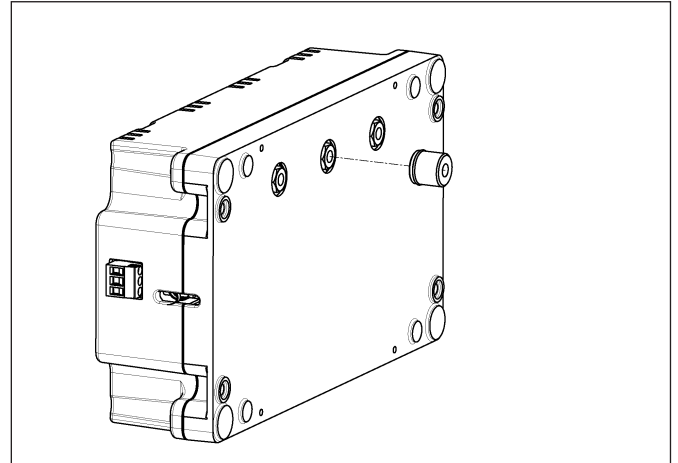

Figure 2. Bus bar extension bushing

4. Mount the SPD to the support brackets (customer supplied) using #10 fasteners and tighten to 4.1 N·m (36 in-lbs). See Figures 3 and 4 for mounting details.

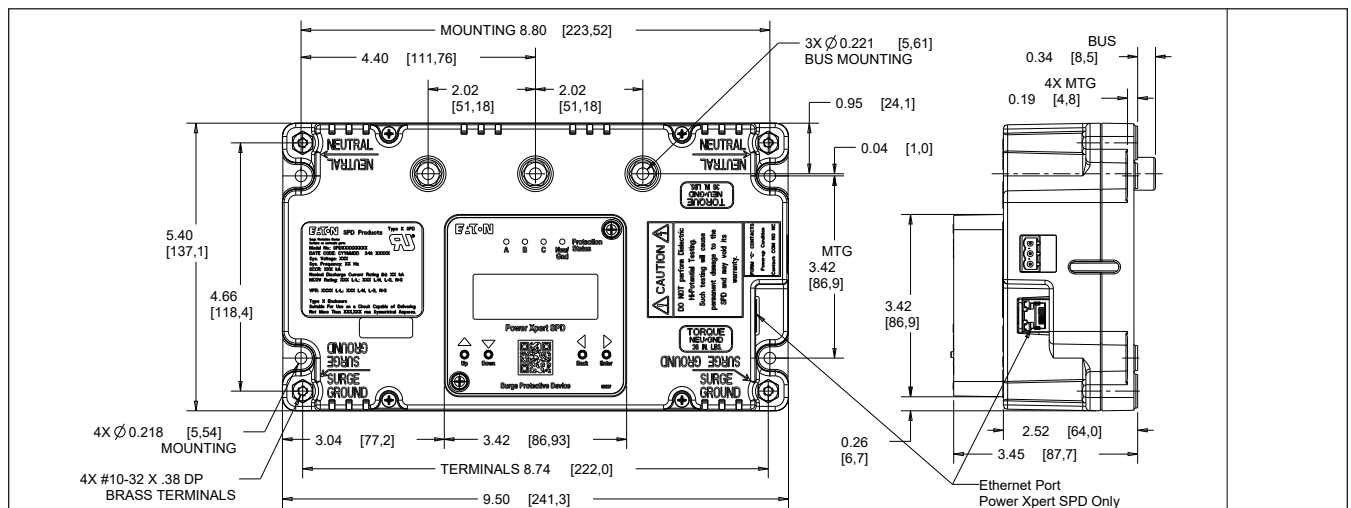

Figure 3. Dimensions for 50-200kA units

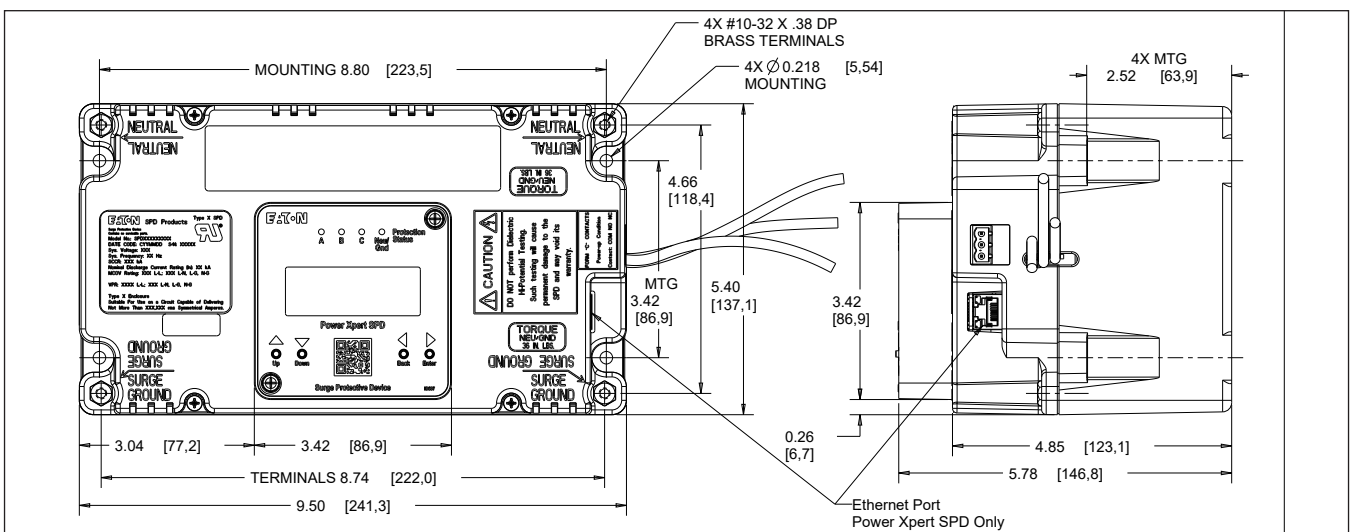

Figure 4. Dimensions for 250-400kA units

5. Install the bus mount fasteners and tighten to 4.1 N·m (36 in-lbs). See Figure 5.

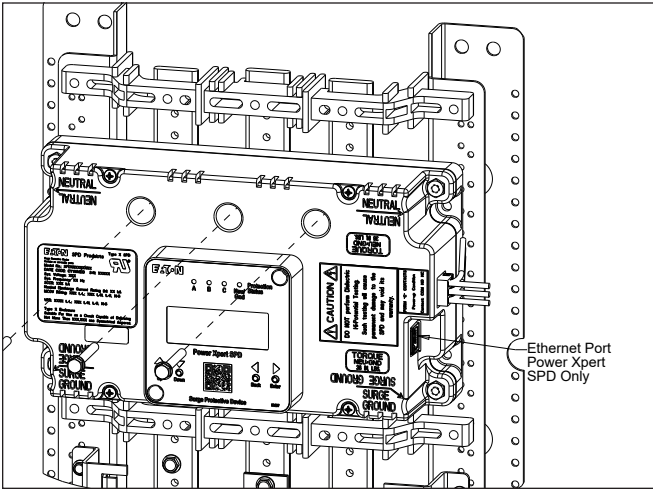

Figure 5. Bus bar extension bushing

6. Select the correct wiring diagram for the SPD you are installing. You must refer to this diagram while wiring the SPD. See Figures 6, 7, 8, 9 and 10.

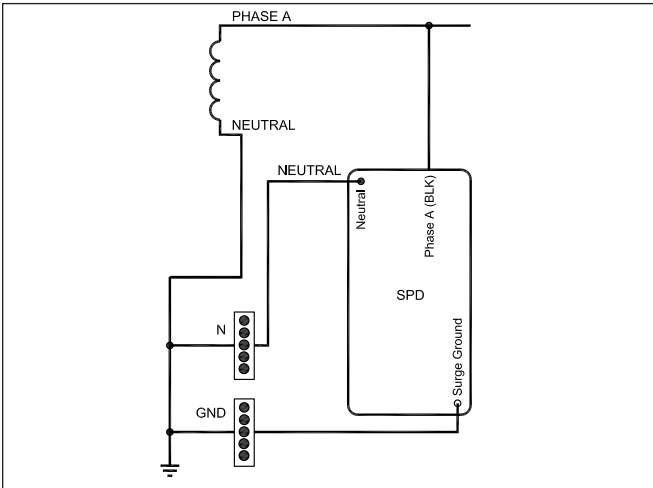

Figure 6. Wiring - single phase units (230 L)

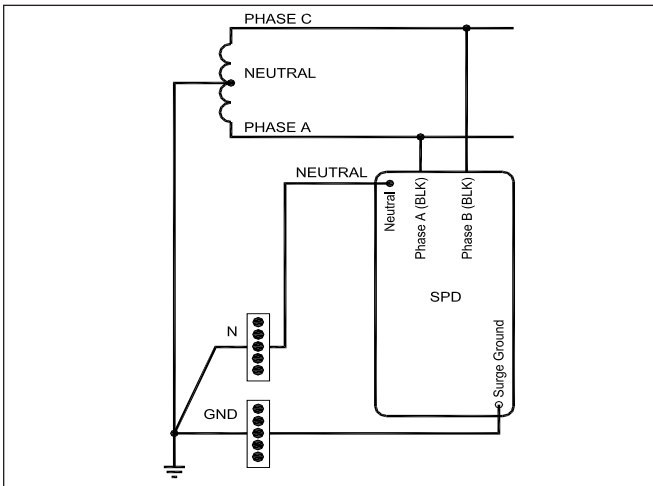

Figure 7. Wiring - split phase units

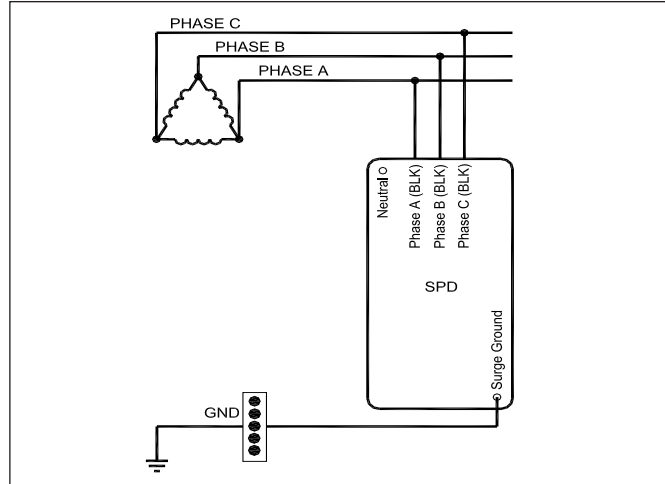

Figure 8. Wiring - 3-phase delta units

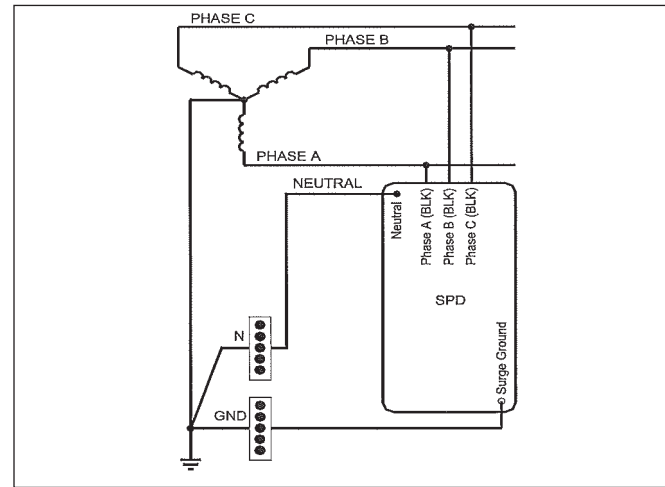

Figure 9. Wiring - 3-phase wye units

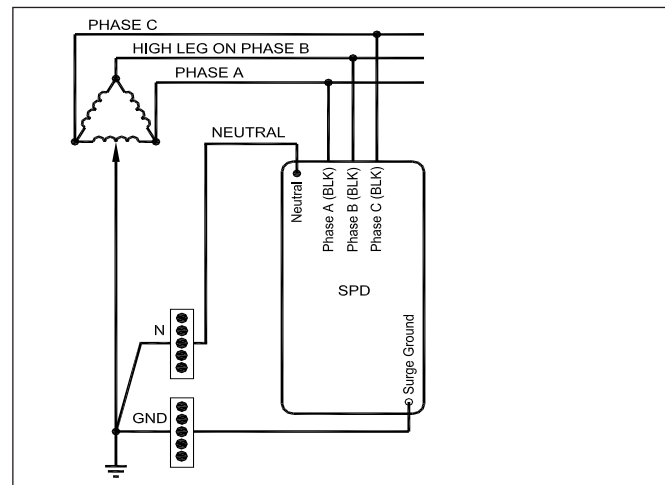

Figure 10. Wiring - high leg delta units

Note: Please consult the factory for 240 delta high leg (4W+G) applications with high leg on the 'C' phase.

- Determine the wire length required to connect to the breaker and cut phase wires to the appropriate length. (To maximize SPD performance, wire length should be as short as possible).

Note: For wire lengths longer than 4", phase wires should be twisted once for each 4" of wire length to maximize SPD performance.

- Connect phase wire to circuit breaker. NEC requires that conductors to a surge device be protected by an overcurrent protection device. The cables on the SPD are #10 AWG, therefore would require a 30A 3-pole breaker. See Figure 15, and the wiring diagrams shown in Figures 6, 7, 8, 9 and 10.

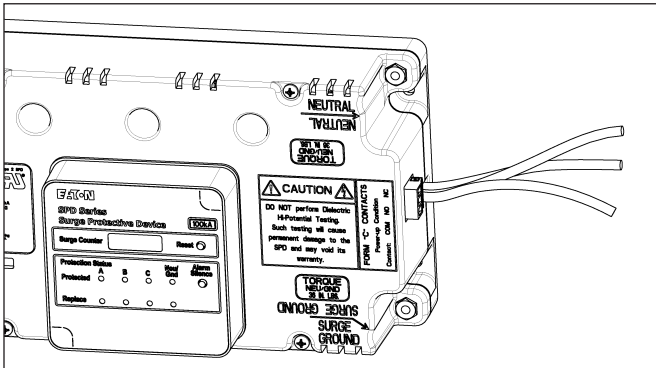

Figure 15. Phase connections

- Connect the system ground wire (green) to the SPD's surge ground connection using a ring terminal suitable for use with a #10 fastener and #10-32 x 3/8" fastener (customer supplied). Tighten the surge ground connection to 4.1 N·m (36 in-lbs). If the system uses an isolated ground, connect the isolated ground wire to surge ground. There are two surge ground connection points provided on the SPD. Connect **only one** of them. See Figure 11.
- If equipped, connect the system neutral wire (grey or white) to the SPD. Connect the system neutral wire to the SPD's neutral connection using a ring terminal suitable for use with a #10 fastener and a #10-32 x 3/8" fastener (customer supplied). Tighten the neutral connection to 4.1 N·m (36 in-lbs). There are two neutral connection points provided on the SPD. Connect **only one** of them. See Figure 12.
- The SPD (Standard, Standard with Surge Counter and Power Xpert models) also have a connection available for remote monitoring of the form C relay contacts. See Figure 13. This is a green connector located on the side of the SPD. To make the connection, remove the green connector and install the remote monitor leads (connector supports 12-24 AWG wire). Fasten the remote monitoring wires to the N.O., N.C. and COM connection points per the label on the front of the SPD. Contacts are rated: 150 Vac at 0.46A, 30Vdc at 1A. Follow all national, state and local electrical codes. With wiring complete, plug the green connector into the SPD.
- The final step of the SPD installation depends on the specific application. The various applications are listed below by catalog suffix.

- Suffix 'B': This is the remote display panel (RDP) option. The RDP option requires the addition of a factory supplied RDP cable. See Section 7, "Remote display panel (RDP) option" for cable catalog numbers.

- Install the RDP using cutout and mounting dimensions provided in Figure 16.

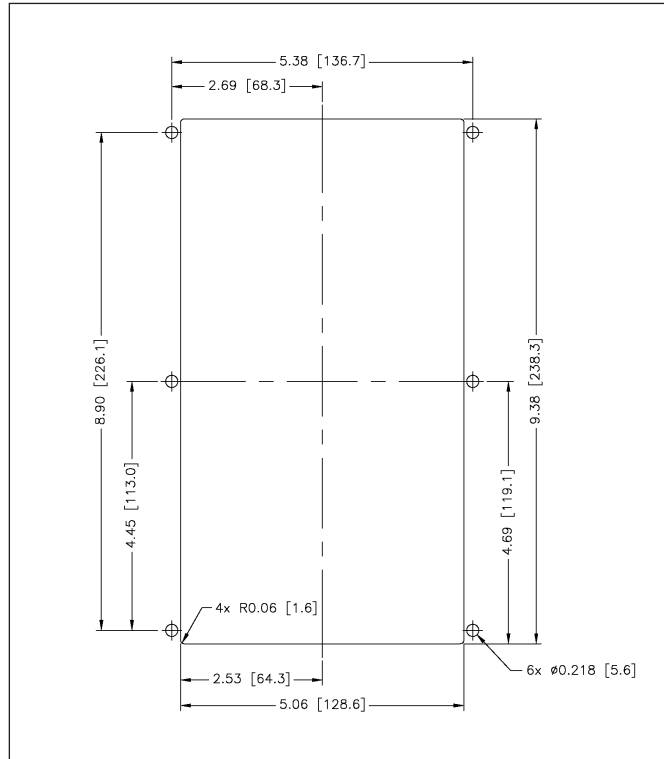

Figure 16. RDP cutout and mounting

- Connect the RDP cable to the SPD. Use tie wraps (already on the SPD) to secure the cable to the SPD. See Figure 17. Cable can be routed as a right or left dress.

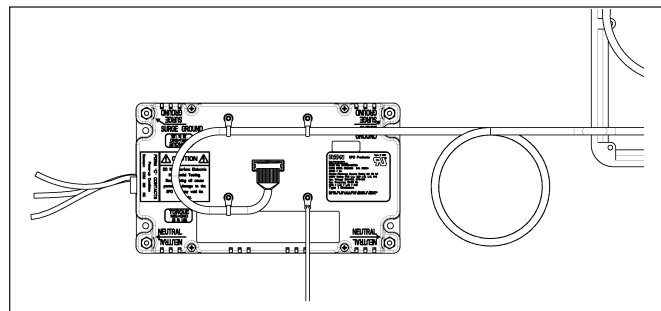

Figure 17. RDP to SPD connection

3. Connect the RDP cable to the display. Use tie wraps (already on the RDP) to secure the cable to the RDP. See Figure 18.

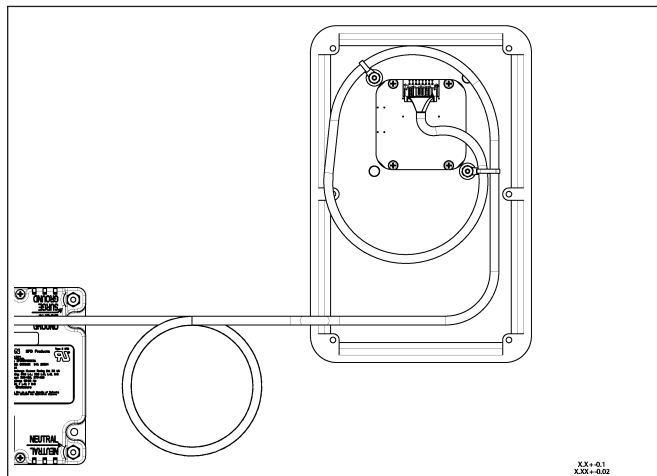

Figure 18. RDP cable to display connection

- b. Suffix 'C': This unit is intended for use in panelboard, switchboard, and busway applications.
 1. Ensure that the dead-front or door has the appropriate cut-out to accommodate the SPD display. See Figure 3 or Figure 4.
 2. Install dead-front or door and secure.
- c. Suffix 'J': This unit is intended for MCC applications that require a NEMA 12 enclosure rating.
 1. Ensure that the MCC bucket door has the appropriate cut-out to accommodate the SPD display. See Figure 3 or Figure 4.
 2. Place an appropriate NEMA 12 rated gasket around the display opening on the inside of the door.
 3. Install the door and secure.

3.0 Operating features

3.1 General

The Eaton SPD Series comes in four feature packages: Basic, Standard, Standard with Surge Counter, and Power Xpert SPD. The operating specifics of each feature package are described below.

The Eaton SPD Series requires no operator involvement, other than to monitor the display panel to determine status of the SPD.

After system power is applied, the SPD automatically begins protecting downstream electrical equipment from voltage transients.

Some SPD units have a form C relay contact that allows for the remote indication of SPD status. Form C contact wires are connected via a three terminal connector. See Figure 13.

3.2 Displays and indicators

All of the Eaton SPD Series units (Basic, Standard, Standard with Surge Counter, and Power Xpert SPD) use a display panel to indicate system status. The display panel is slightly different for each feature package.

The display in features 1, 2 and 3 have both green and red light emitting diodes (LEDs) to indicate the status of protection on each phase. Green indicates the phase is fully protected. Red indicates a loss of protection. Wye, split phase and high-leg delta units have an additional set of green/red LEDs to indicate status of neutral/ground protection.

The display in feature 4 has green, yellow and red illuminating LEDs to indicate the status of protection in phases A, B and C. Systems with a neutral wire will show the status of protection in N-G mode.

When an LED turns red, an audible alarm will sound on units equipped with an audible alarm.

For features 1, 2 and 3 push the alarm silence button to silence the alarm. For the Power Xpert SPD push any of the four push-buttons on the display to silence the alarm.

Specific operating conditions displayed for each Eaton SPD Series feature package are described below.

3.2.1 Basic feature package

The Basic feature package has the following features:

- Green LEDs: Illumination indicates the phase is fully protected, and operating normally, with all protection active and available. Green LEDs also indicate neutral to ground protection on units with a neutral wire. Green LEDs do not indicate on/off status of power.
- Red LEDs: Illumination indicates a loss of protection, and that one or more protective devices are now inactive and unavailable for that phase. Red LEDs also indicate neutral to ground protection on units with a neutral wire. Red LEDs do not indicate on/off status of power.



Figure 19. Basic feature package display

3.2.2 Standard feature package

The Standard feature package has the following features:

- All the features of the Basic feature package.
- One form C relay contact rated at 150 Vac at 0.46A, 30Vdc at 1A.
 - Normal operating conditions. N.O. = OPEN. N.C = CLOSED.
 - Loss of protection on any phase or loss of power. N.O. = CLOSED. N.C. = OPEN.
- Audible alarm with an alarm silence button.
- EMI/RFI filtering.



Figure 20. Standard feature package display

3.2.3 Standard with Surge Counter feature package

The Standard with Surge Counter feature package has the following features:

- All the features of the Standard feature package.
- LCD screen that displays surge count.
- Reset button to RESET the Surge Counter to zero.

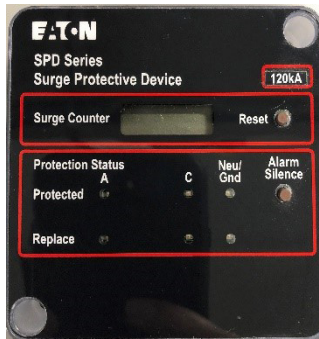

Figure 21. Standard with Surge Counter feature package display

3.2.4 Power Xpert SPD feature package

All features of the Standard with Surge Counter feature package including advanced monitoring and communication.

- Display upgraded to a 20x4 character liquid crystal display (LCD)
- Power Xpert Gateway (PXG900) with firmware version 4.6.4 and higher are Modbus TCP supported and configurable with the ability to receive email notifications. Modbus TCP/IP must be enabled on the PX SPD prior to use.
- LCD main menu options include the following:
 - SPD status - surge event logs
 - Event logs – all events including phase protection percentage, phase loss, alarm status, power on/off, and low, medium and high level surges.
 - Settings - includes device setup, changing the password and the option of giving the device a unique name.
 - Identification - information on the device.
- One form C relay contact rated at 150Vac at 0.46A, 30Vdc at 1A. Normal operating conditions. N.O. = OPEN. N.C = CLOSED. Loss of protection on any phase or loss of power. N.O. = CLOSED. N.C. = OPEN.
- Audible alarm with push any button to silence.
- EMI/RFI filtering.
- Remote monitoring via web UI, Modbus TCP/IP or BACnet/IP protocols. Modbus, BACnet and HTTP are initially disabled for cybersecurity purposes.
- Phase surge event counters.
- Time/date stamp event logs.
- Green LEDs: Illumination indicates the phase is fully protected (100%), and operating normally, with all protection active and available. Green LEDs also indicate neutral to ground protection on units with a neutral wire. Green LEDs do not indicate on/off status of power.
- Yellow LEDs: Illumination indicates a partial loss of protection (>1% to 99%), and that one or more protective devices are now inactive and unavailable for that phase.
- Red LEDs: Illumination indicates a total loss of protection(0%), and that one or more protective devices are now inactive and unavailable for that phase. Red LEDs do not indicate on/off status of power.
- LCD technology is readable above -20°C, however surge protection is fully functional to -40°C.



Figure 22. Power Xpert SPD display

4.0 Power Xpert local display overview

The Eaton Power Xpert SPD feature package includes a 20x4 LCD module which on power up displays the device's home screen which includes the following: catalog number, device name (which is editable by the user), time, and firmware version.



Figure 23. Power Xpert SPD home screen

To enter the main menu from the home screen, push the enter key. The following selections will then appear on the screen. The less than symbol "<" represents the cursor location and will appear to the right of the selected menu category. Press the down arrow to scroll down through the selections or press the up arrow to move up. Press the enter button to select a menu item or press the back button to return to the previous menu screen.



Figure 24. Power Xpert SPD main screen

4.1 SPD main menu selections

The main menu consists of four menu selections.

4.1.1 SPD status

Includes the following sub-menu selections.

Surge events – which contains a subset of menu selections that includes events that occurred on each phase, the level of the surge event (low, med, high) on each phase, the total number of surges on each phase and the total surges and their level (low, med, high)

Protection level – percentage of surge protection remaining in the device per phase.

Alarm status – status of the alarm "Protected" or "Active Alarm Replace SPD"

4.1.2 Event log

Includes the follow sub-menu selections.

All events - Up to 40 events which includes surges, power up, power loss, protection reduced (%), protection loss, and alarm silence with time and date stamps of when the event occurred are viewable to the user.

Low, med and high level surges - Up to the last 20 date stamped events.

4.1.3 Settings

A valid User password must first be entered and confirmed before a user can access the following selections.

Set date and time – set the current time and date for accurate date and time stamped events. (Automatically synced when connected to a network.) Temperature variations and other factors can affect accuracy. Also, if the unit has been without power for an extended period of time the date and time will have to be re-entered.

Set device name – name the device to distinguish it from other devices on your network. Device name can be up to 20 alpha numeric characters.

Start display test – cycles through the LED states and then turns on and off the LCD pixels.

Change password – changes the device password. Requires a 6-digit numeric password.

Clear surges & logs – Clears all surge counts and event logs

Sensitivity setting – Increase or decrease the low surge sensitivity. It is not recommended for the user to modify this setting without first contacting Eaton Customer Support at 1-800-809-2772 or email SPD@eaton.com.

Communications – configure Modbus TCP, ethernet, and IP, subnet mask, and gateway addresses. BACnet must be configured through the web UI. See Appendix F for the Modbus register map. See Appendix H for the BACnet register map.

4.1.4 Identification

This section contains information about the device itself. It includes the following:

- Catalog number
- Style number
- Date code
- Firmware version
- PCB serial number
- Device name
- MAC address
- Customer support information

This information is necessary when contacting customer support concerning the device.

5.0 Power Xpert SPD user setup

5.1 General

The Eaton Power Xpert SPD can be set up using just the local display or with a laptop, Cat 5e cable and a web browser. Modbus, BACnet, and HTTP are initially disabled to provide cybersecurity protection. Modbus can be enabled through the LCD module or the web UI. BACnet and HTTP can only be enabled through the web UI. The PX-SPD must be rebooted after enabling Modbus or BACnet communications.

5.2 Setup using only the local display

Once the SPD has been powered up the device's home screen will appear on the local display. See below. The home screen shows the catalog number of the device, the device's name, the time and the firmware revision.



Figure 25. Power Xpert home screen

Setting up the date and time

To set the current date and time, press enter to go to the main menu.



Figure 26. Power Xpert main menu

Now scroll down the menu to settings by pressing the down arrow button. The cursor "<" is located to the right of the menu category selection. Position the cursor to the right of settings< by pressing the down button twice and then press enter.



Figure 27. Move cursor to settings

Next, enter a 6-digit password by pressing the up button to the desired first number, if you go past the number press the down button. Then press enter to go to the next digit. Repeat the process until all 6 digits have been entered. After all 6 digits have been entered press enter to continue.



Figure 28. Password screen

Next, select the date and time category by pressing enter.



Figure 29. Select date and time

Next press the enter button to edit the date and time or the back button to exit and return to the previous screen.



Figure 30. Setting date and time

Press up to enter the month, then press enter to move to the date selection. Press up to enter the date, then press enter. Next press up to scroll to the current year. Press enter to move to hours and repeat the process for minutes and seconds. Finally press enter to save the settings and then return to the previous screen. (Time will initially be displayed in UTC time on the web UI. This can be changed through the web UI.)

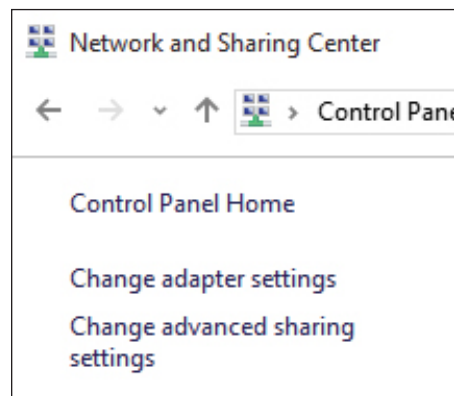

Figure 31. Saving the date and time

5.2.1 Configuration of the user's laptop to communicate to PX-SPD

Follow these steps to enter the IP and Subnet Address on the user's laptop or PC.

1. In Windows applications, navigate to Network and Sharing Center.



2. Click on Change adapter settings.

3. Left click on Ethernet and then right click to open the window shown below. Then click on properties.

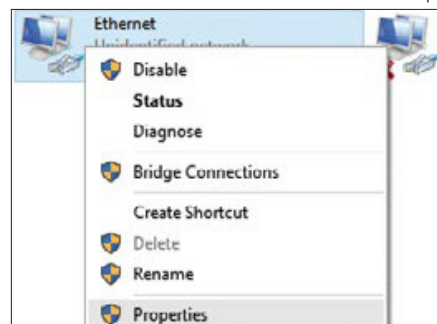

4. Click on Internet Protocol Version 4 (TCP/IPv4).
5. Click on properties.

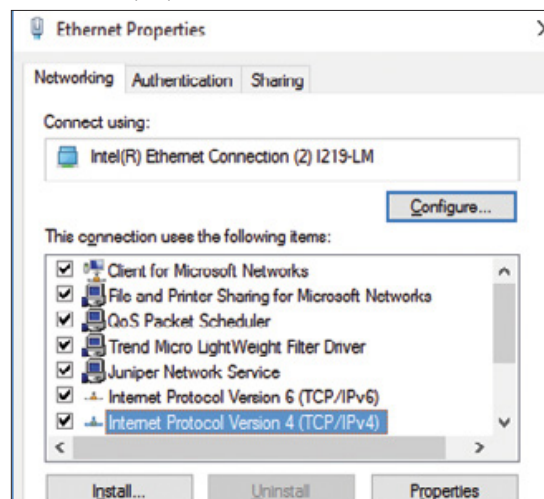

6. On the General tab, select Use the following IP address:
 - a. Enter 192.168.1.10 for the IP Address.
 - b. Enter 255.255.255.0 for the Subnet Mask.
 - c. Enter 192.168.1.1 for Default gateway.

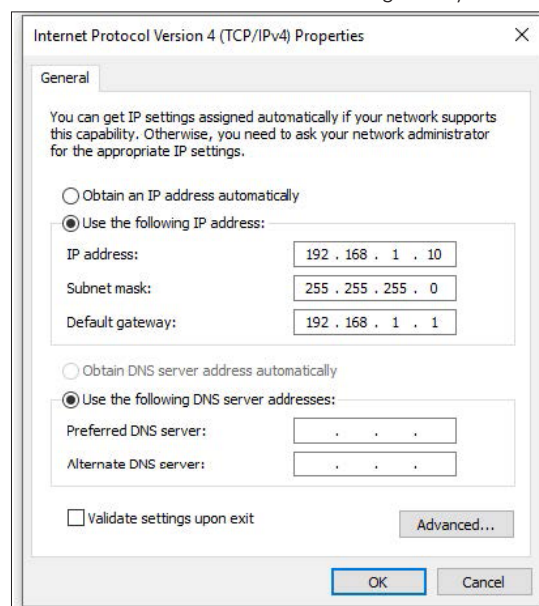

7. Click on OK button and then exit out of all these open windows.

5.3 Power Xpert SPD Network Connection.

Plug one end of a Cat5e ethernet cable into the SPD and the other into a laptop PC which is connected to a network. The device comes from the factory with the default IP address listed below but can also be set up for dynamic IP (DHCP) or a user defined Static IP address.

Default IP address is: 192.168.1.254

Default user: admin

Default password: Admin*1

Open Google Chrome, or Internet Explorer 11.x or higher and enter the fixed IP address 192.168.1.254 and then hit the enter key.

This window will open.

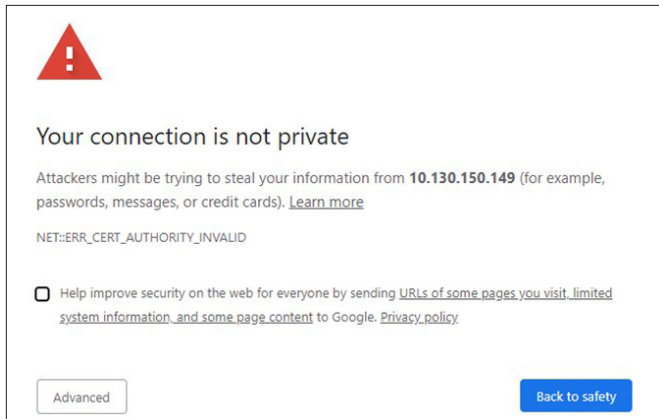

Click on Advanced.

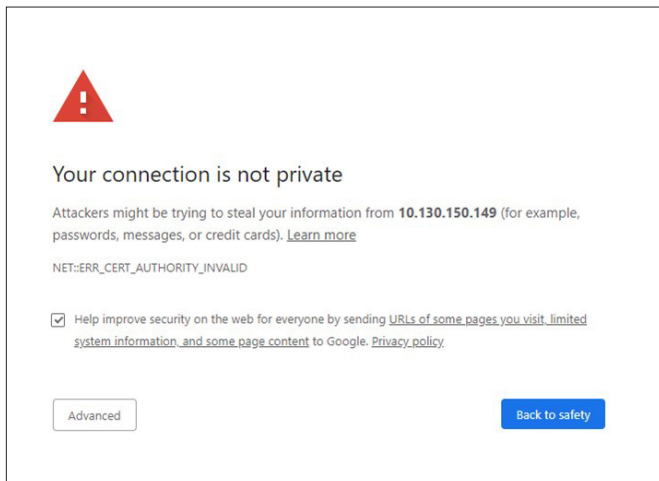

Click on "Proceed to..." near the bottom of the window.

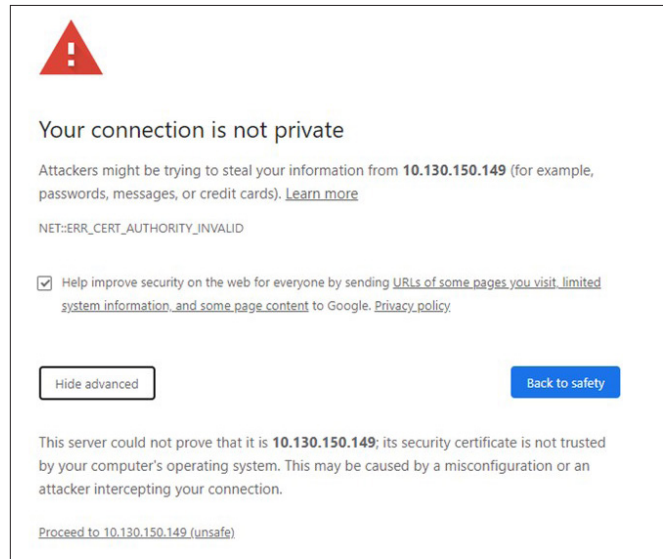

The login screen shown below will open. Enter the default user name and password shown above and hit the enter key.

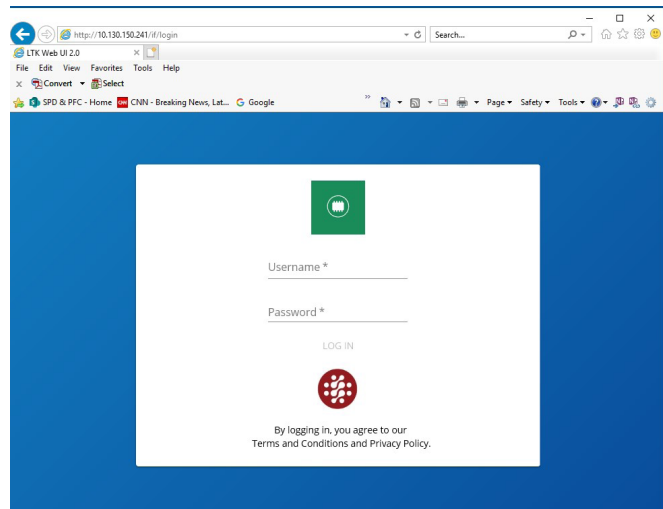

Figure 32. Power Xpert login screen

The change password window will open. Enter the default password and then enter a new 6 digit alpha-numeric password and then click OK. Save password in a secure location to access the Web UI. If lost, contact Eaton's Application Engineers, at 1-800-809-2772, or email SPD@eaton.com.

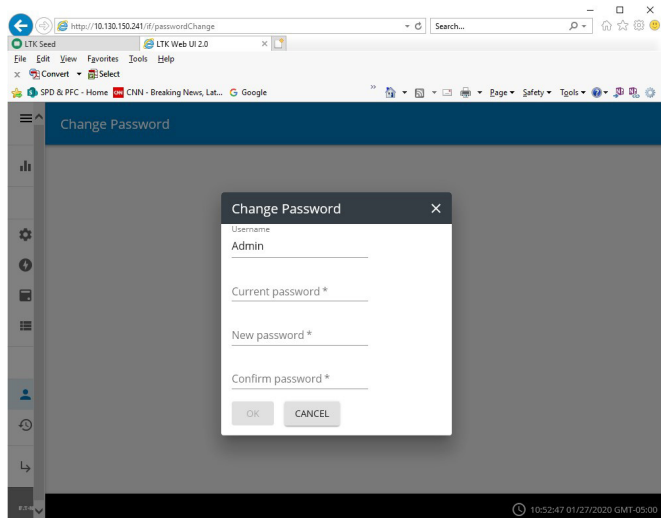

Figure 33. Password screen

Then it will return to the overview screen.

Password security: The Power Xpert SPD is shipped with factory default user authentication credentials to allow for initial installation and configuration. However, factory default authentication credentials are often well known, easily discoverable and present a significant security risk; therefore, the admin user name and admin password should be changed at installation to increase cybersecurity protection.

1. Limit access to the PX-SPD to reduce cybersecurity risk.
2. The maximum number of users that can be setup is six.
3. User names should be 5 characters in length or more.
4. Password expiration is configurable, the default is set to 90 days.
5. Up to three users can access the PX-SPD simultaneously.

Admin users assign a role to new users from one of four possible roles under the User Management tab through the web UI.

Table 2. User role privileges

Role	Description	IP Addr	Modbus TO	User/Pass	Factory Reset	Reboot
Admin	All privileges	R/W	R/W	R/W	R/W	R/W
Engineer	Product configuration	R/W	R/W			
Operator	Read only	R	R			
Viewer	Read only	R	R			

R – Read access
W - Write access
IP Addr – IP Address configuration
Modbus TO – Modbus timeout value
User/Pass – Username and password setup

PX-SPD enforces complex passwords and session time-out through User Management tab in the web UI.

There are 4 levels of Password Complexity, defined as follows:

- Password complexity level – 0
 - It should be at least 6 characters long
 - It should not match with user name, full name or existing password
- Password complexity level – 1
 - It should be at least 8 characters long
 - It should not match with user name, full name or existing password
 - It should contain at least 1 alphabetic and 1 numeric character
- Password complexity level – 2
 - It should be at least 12 characters long
 - It should not match with user name, full name or existing password
 - It should contain at least 1 alphabetic, 1 numeric character, 1 special character, and 1 upper case alphabetic character
- Password complexity level – 3
 - It should be at least 16 characters long
 - It should not match with user name, full name or existing password
 - It should contain at least 2 alphabetic characters, 1 numeric character, 2 special characters, and 1 upper case alphabetic character.

Admin Users: It is mandatory to provide password complexity level when creating a new user.

The change password window will open. Enter the default password and then enter a new 6 digit alpha-numeric password and then click OK. Save password in a secure location to access the Web UI. If lost, contact Eaton’s Application Engineers, at 1-800-809-2772, or email SPD@eaton.com.

5.3.1 Establishing a secure connection

After initial login, the user will notice that the address bar on the web browser shows that the connection is Not secure, see example below.



To obtain a secure connection, click on the network tab, then click on download certificate.

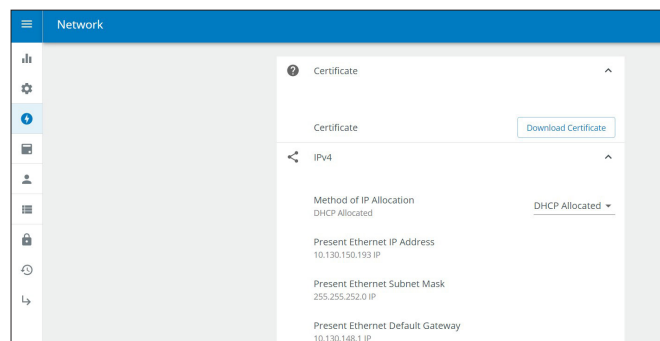

Figure 34. Download certificate

Download the certificate file, cert.cer. Open the cert.cer file.

The install certificate window will then open and then click on Install Certificate button.

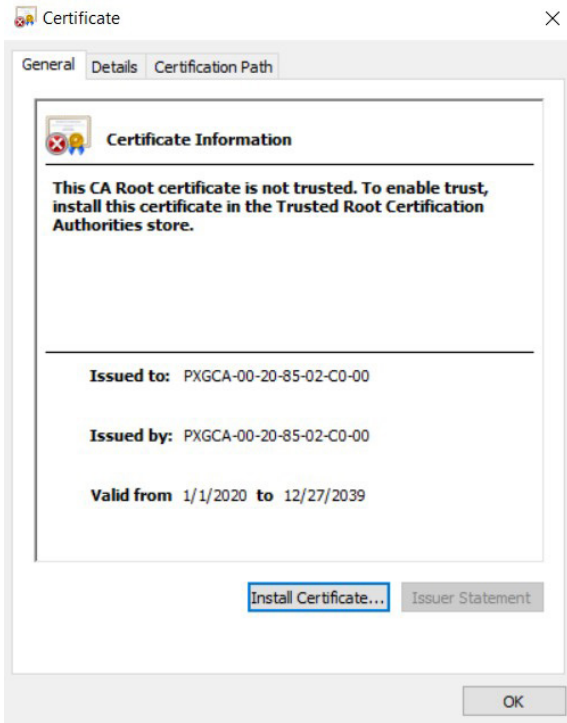

Figure 35. Install certificate

Then the Certificate Import Wizard will open. Select current user and then click next.

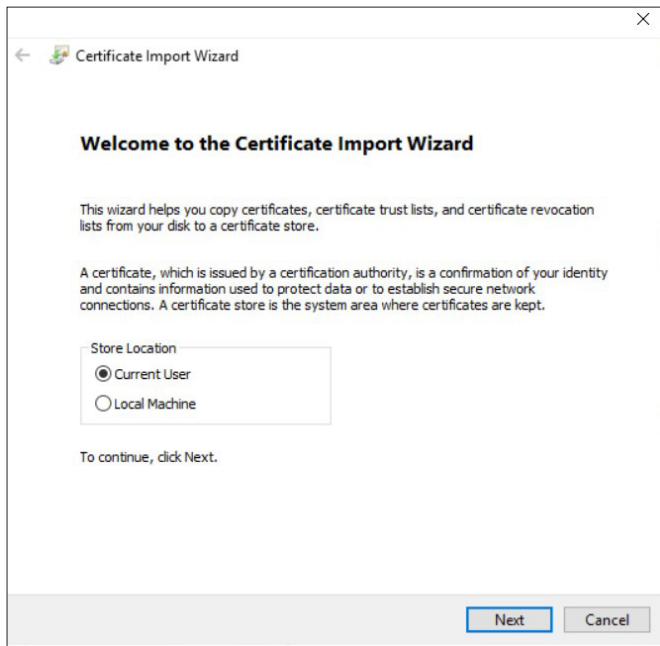

Figure 36. Certificate Import Wizard

In the next window click on 'Place all certificates in the following store'. Then click the browse button and then the select certificate store window will open. Next select 'Trusted Root Certification Authorities' from the menu and then click OK. Then select next.

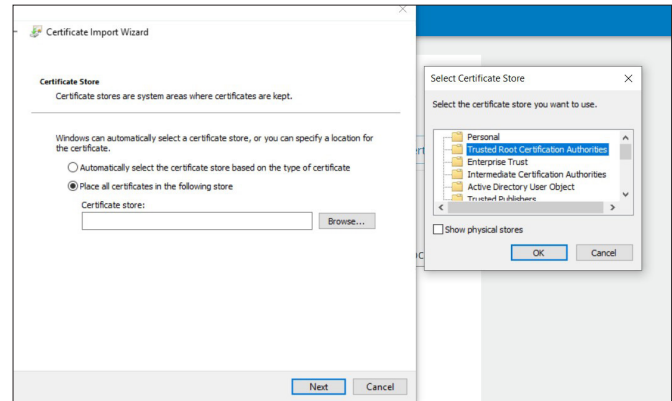

Figure 37. Certificate storage location

Then select finish in the window.

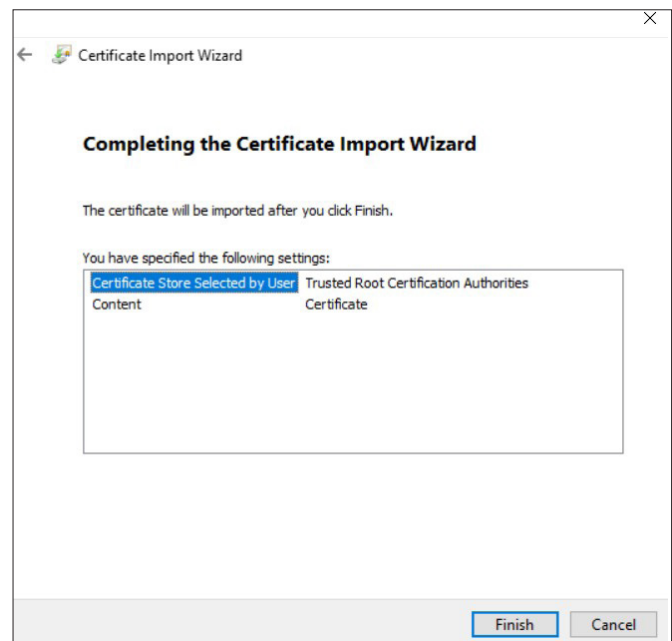

Figure 38. Certificate download finish

Then select yes when the security warning window pops up.

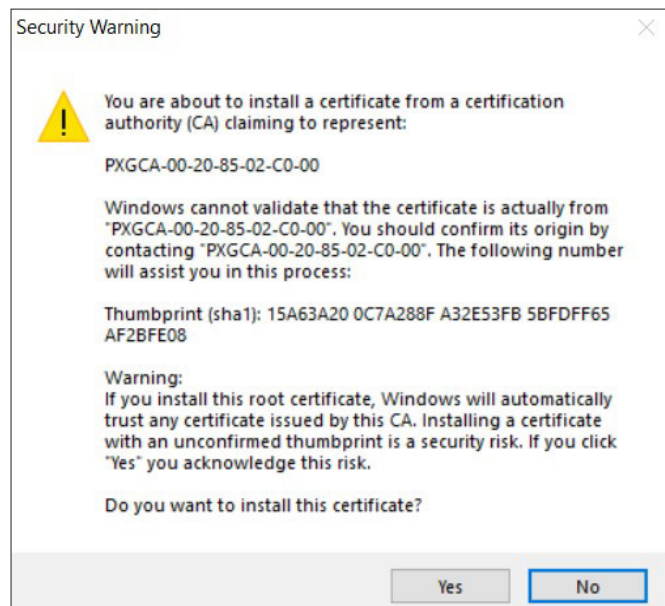

Figure 39. Security warning window

If the import is successful you will receive a pop up window notification as shown below.

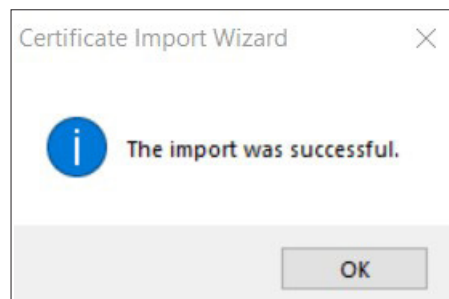

Figure 40. Import successful

Logout of the device, close the browser, reopen the browser and then re-enter the device's IP address using secure login beginning with https:// followed by the device's IP address. Once logged in, the address on the toolbar should show the locked padlock symbol similar to the one shown below.



Figure 41. Successful secure login

5.3.2 Upgrading firmware

To update the firmware in the Power Xpert SPD, go to the Eaton website at www.eaton.com/PXSPD and download the latest version firmware to a laptop or PC.

Connect the laptop to the Power Xpert SPD via an ethernet cable and login to the SPD. Once logged in, scroll to the toolbar on the left and select Firmware from the menu.

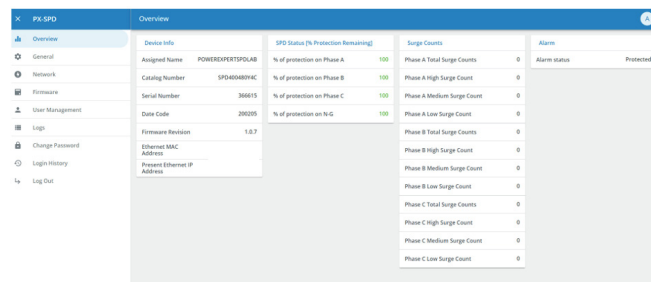

Figure 42. Select the Firmware tab

The window below opens and then select "OPEN CODEPACK".

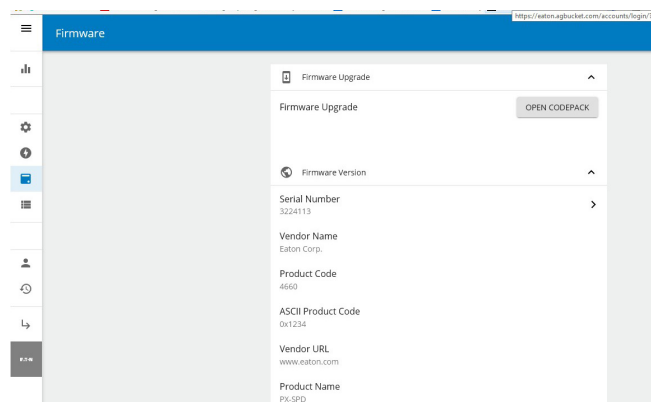

Figure 43. Select "OPEN CODEPACK"

A window will open to allow the user to browse their hard drive to the place where they saved the downloaded firmware. Select the *.xml file and click open. The End-User License Agreement window will appear. Check the "I agree to the terms of the License Agreement" and then click accept. The firmware update window will open and then click "Select Processor". The firmware/code pack evaluation window will open and then click on the box to the left of PX-SPD_MAIN_PROCESSOR and then click Ok. A status window will open and show the status of the download.

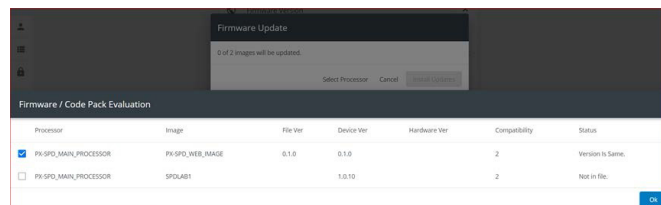

Figure 44. Select PX-SPD_Main_Processor

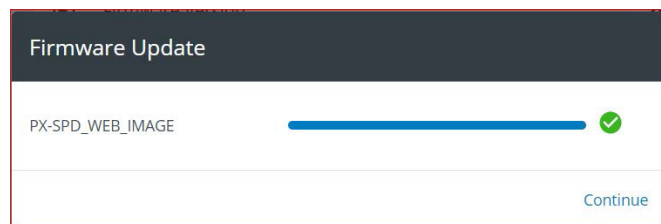

Figure 45. Firmware Update complete

Once the download has been completed the device will return to the login screen.

Login to the device and click on the General tab and verify the SNTP server 1 has a green circle around it, as shown below. This verifies the device has synced with the network and will provide accurate time stamped events.

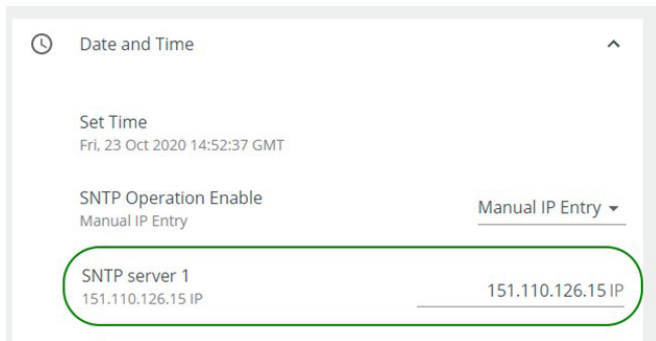

Figure 46. SNTP sync confirmed when circled in green.

5.3.3 Viewing surge logs

To view surge logs hover over the toolbar and then click on logs. (Modbus must be enabled in order to view surge and general logs.)

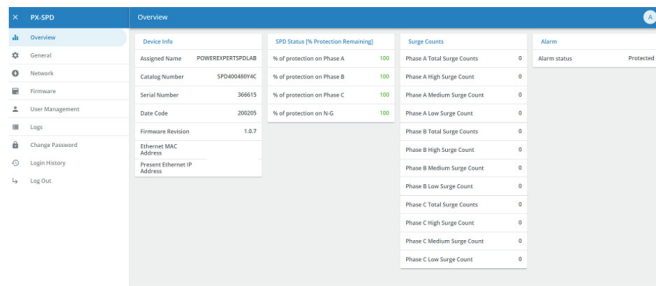

Figure 47. Log screen

Next click on list of logs in the upper left corner of the window.

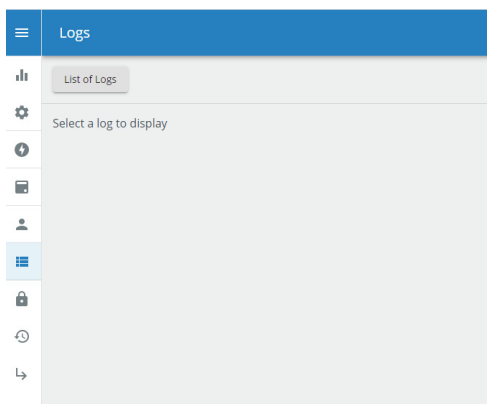

Figure 48. Select list of logs

A dropdown will open displaying the options available to the user. Select the log of interest.

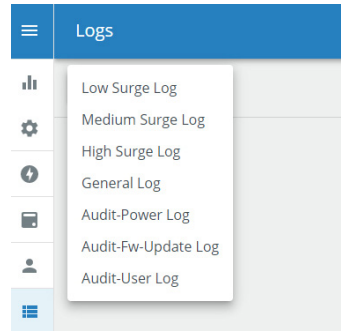

Figure 49. Logs that are available to view

Low, Medium and High Surge Logs display specific phase surges that occurred in a particular surge category. General Log displays phase protection reduction percentage, phase protection loss, alarm silenced, power on/off. Audit-Power Log displays when the device restarted after a power loss. Audit-Fw-Update Log displays code update history. Audit-User Log displays when Users logged in and out of the device. Once in the log, a list of logging events and their time stamps are displayed. The user has the option of scrolling down through the list or exporting the logs to a *.csv file using the Export Log button in the upper right corner of the screen. In addition, the user can clear logs in that particular log if they choose to do so.

General settings

The user will be prompted before either of these actions. Click the 'X' in the top right of the window to cancel this action.

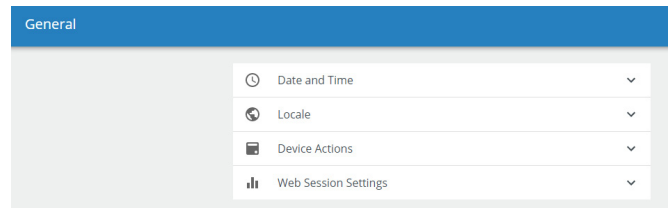

Figure 50. General settings

Syncing the internal clock.

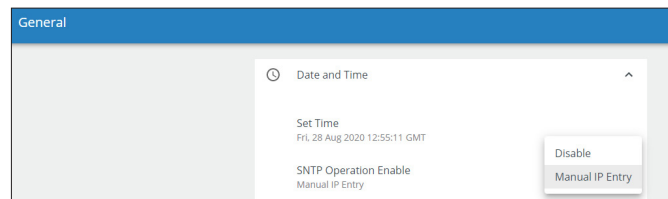

Figure 51. Sync the internal clock

Select the appropriate timezone from the dropdown list to the right of Timezone. GMT-05:00 represents Eastern Standard Time, GMT-06:00 represents Central Time, etc. Date format, with four different date formats to choose from, and the time format.

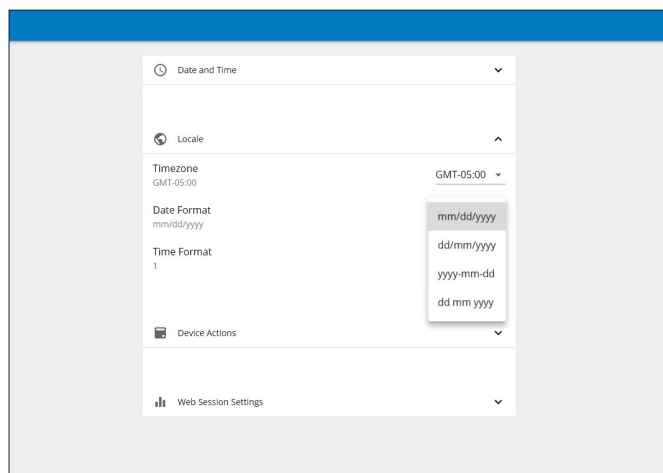

Figure 52. Select time format

Device Actions has two options for the Admin user. Reboot or Reset Device. Reboot is a soft reset, the micro controller will power down and power up. Reset is a hard reset which will reset the device to factory defaults. Either action can only be conducted by an Admin user.

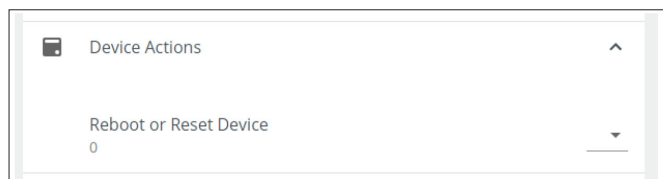

Figure 53. Device actions

The user will be prompted before either of these actions. Click the "X" in the top right of the window to cancel this action.

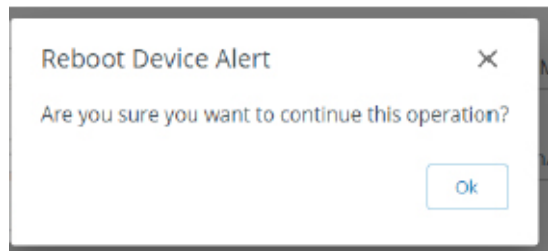

Figure 54. Reboot device alert

The Admin user can modify timeouts, number of concurrent sessions and the number of failed login attempts.

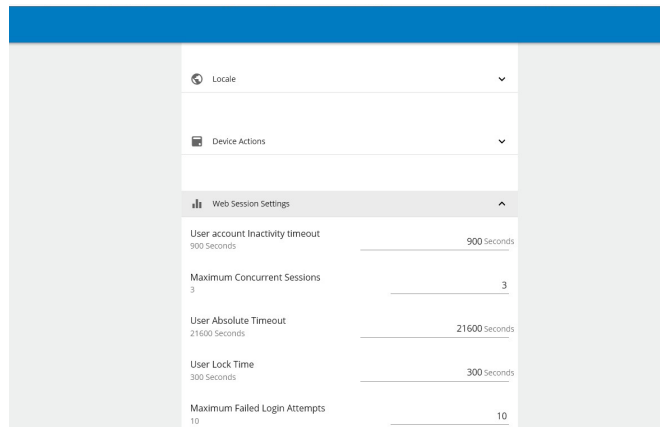

Figure 55. Modifying timeouts

In the network window the following options are listed.

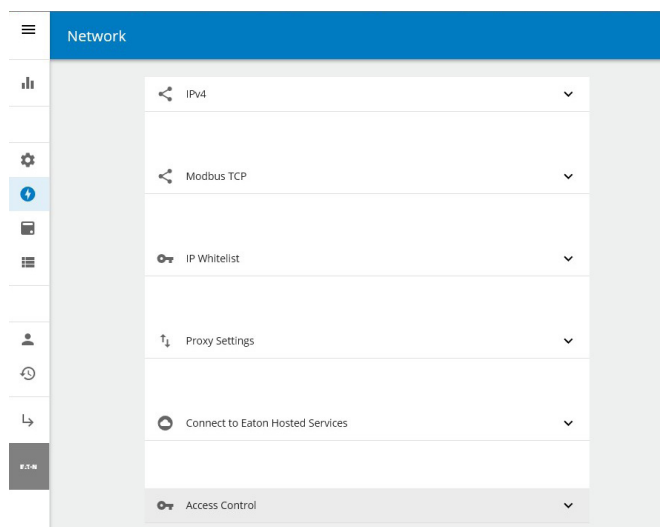

Figure 56. Network tab options

The user can select the IP allocation method between three options and the IP address is also displayed here. The IP allocation method change does not take effect until the unit has been rebooted. The reboot command is available under General tab, Device Actions. (Do not select the Factory Reset command or the device will return to the factory default value with a static IP address.)

IP Allocation Methods available:

- Statically Hardcoded (192.168.1.254) Factory default
- DHCP Allocated (Network assigned)
- Taken from NV (stored IP address)

Note: The User must reboot the device after performing any of these changes.

Communication setting changes require a reboot of the micro controller to enable it.

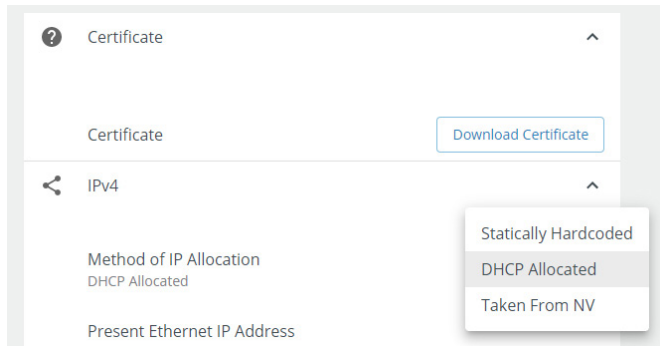

Figure 57. Method of IP allocation

IP configuration changes require a reboot of the device

To initiate a soft reset from the WebUI, go to the general tab and click on the down arrow across from reboot or reset device as shown below.

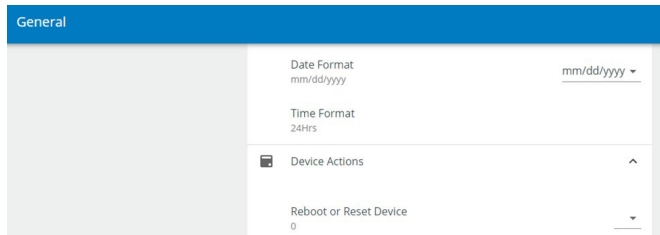

Figure 58. Select on down arrow

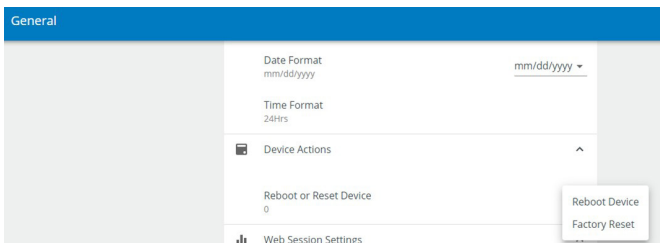

Figure 59. Click on reboot device

Click OK to verify that you want to continue with this operation. The LEDs on the display will turn off, then back on again to indicate that this command has been implemented.

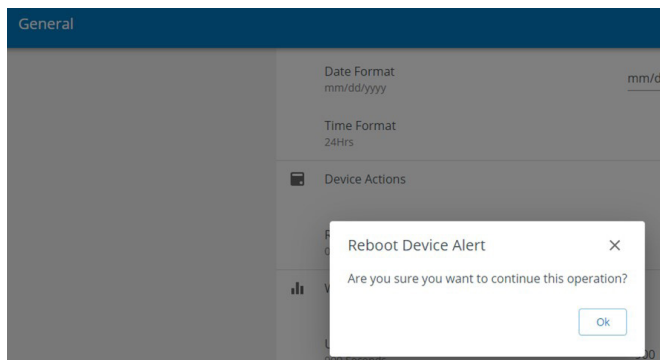

Figure 60. Confirm reboot

A pop up window opens to confirm the reboot.

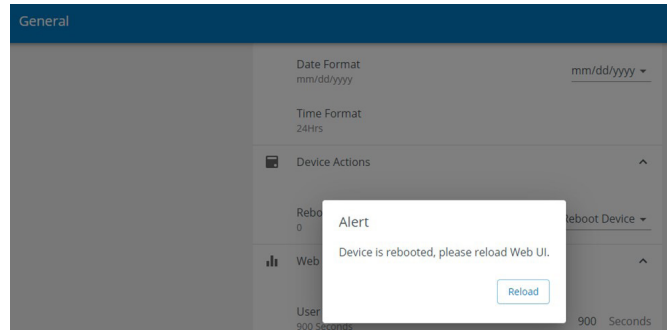

Figure 61. Click on reload

5.3.4 Modbus and BACnet access

The PX-SPD supports Modbus TCP and BACnet/IP using the ethernet port, both are initially disabled. Using Modbus commands, events and logs from the connected SPD. You will need a Modbus TCP capable application such as ModScan which act as the Modbus primary and the SPD is the Modbus secondary. Refer to Appendix F Modbus register map for details on available registers and their properties. Refer to Appendix H for the BACnet register map.

5.3.5 Sensitivity setting

Attention: Eaton does not recommend the customer modify the sensitivity setting without first contacting Eaton Customer Support at 1 800 809-2772 or email SPD@eaton.com. Increasing the sensitivity setting will reduce the number of low level surge counts.

5.3.6 How to reset the PX-SPD password

To reset the Power Xpert SPD password through the local display, the user must first access the concealed menu. To gain access to the concealed menu return to the home screen, then press the following buttons in order within 5 seconds: up, up, down, down, back, back, enter, enter. This will take you to the concealed menu. Follow the screen prompts to reset the password. When this password reset command is activated the local display and Web UI passwords are reset to their default values. The Power Xpert SPD local display prompts the user for a 6 digit numeric password to be entered before being able to enter the settings menu. The web UI user name and password returns to default:

User name: admin
Password: Admin*1

5.3.7 End of life disposal

Before disposing of this device go to Device Actions and select Reset Device to clear logs of any data.

Table 3. Viewable events

Event type	Web UI viewable logs				LCD viewable logs						
	General log last 500 events	Low surge log last 2000 events	Medium surge log last 1500 events	High level surge log last 1000 events	Audit power log	Audit fw update log	Audit user log	All events last 40 events	Low level surges last 20 events	Medium level surges last 20 events	High level surges last 20 events
Phase A protection reduced to %	X							X			
Phase B protection reduced to %	X							X			
Phase C protection reduced to %	X							X			
N-G protection reduced to %	X							X			
Phase A protection loss	X							X			
Phase B protection loss	X							X			
Phase C protection loss	X							X			
N-G protection loss	X							X			
Audible alarm silenced	X							X			
Power off/ power loss	X							X			
Power on/ power restored	X							X			
Phase A low, medium or high surge		X	X	X				X	X	X	X
Phase B low, medium or high surge		X	X	X				X	X	X	X
Phase C low, medium or high surge		X	X	X				X	X	X	X
Device restart						X					
Firmware update time stamp							X				
User login & logout								X			

6.0 SPD display rotation

The SPD display can be rotated on the SPD enclosure, up to 360 degrees. This allows you to position the display for the best visibility regardless of the position in which the SPD is installed.

Rotations are at 90, 180, and 270 degrees.

For a typical horizontal mounting see Figure 62. For a typical vertical mounting see Figure 63.

Reposition the SPD display as follows:

1. Remove power from the unit.
2. Remove and discard the perforated overlay material at the two opposite corners of the display.
3. Remove the two Phillips head screws that hold the display.
4. Rotate the display to the desired position. Be careful not to overstress the display ribbon cable.
5. Place the display back onto the SPD enclosure. Again, be careful not to overstress or crimp the ribbon cable.
6. Replace the two Phillips head screws. Tighten screws to 1.35 Nm (12 in-lbs).
7. Restore power to the unit.

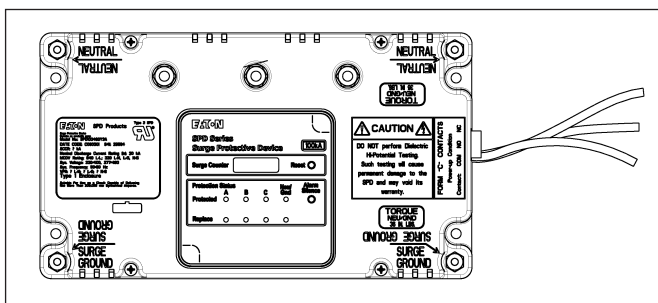

Figure 62. Typical horizontal display mounting

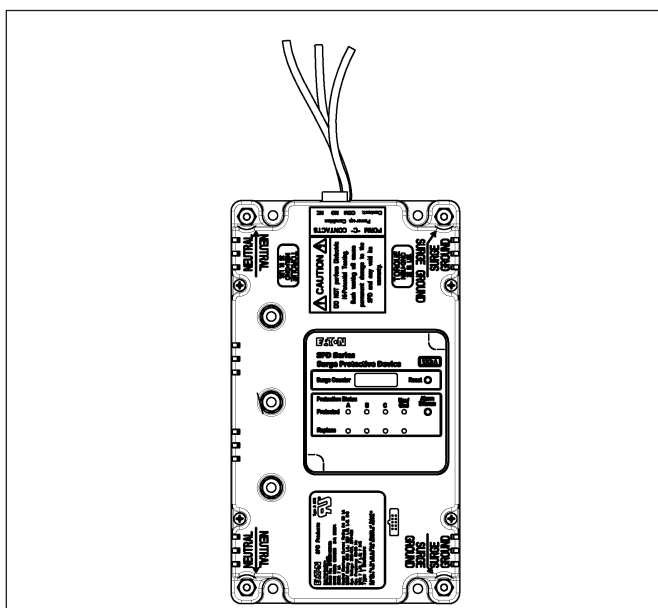

Figure 63. Typical vertical display mounting

7.0 Remote display panel (RDP) option

The Eaton Series SPD displays may be monitored on a remote display panel (RDP). This is indicated by the catalog style with a 'B' suffix (such as SPD250480D2B).

A separately purchased RDP cable is required to connect the SPD unit to the display.

Table 4 and Table 5 list the cable options and their part numbers.

Table 4. Remote display cable options for feature package 1, 2, 3

Description	Catalog No.
4 ft. cable for RDP	SPDRDCAB04
8 ft. cable for RDP	SPDRDCAB08
12 ft. cable for RDP	SPDRDCAB12

Table 5. Remote display cable options for Power Xpert SPD

Description	Catalog No.
4 ft. cable for PXSPDRDP	PXSPDRDCAB04
8 ft. cable for PXSPDRDP	PXSPDRDCAB08
12 ft. cable for PXSPDRDP	PXSPDRDCAB12

8.0 IEC approved models

Eaton's One-Port low-voltage Surge Protective Device Wye Models SPD120480Y2C, SPD160480Y2C, SPD200480Y2C and Delta Models SPD120480D2C, SPD160480D2C, SPD200480D2C meet the requirements of IEC 61643-11 / EN 61643-11, Part 11: Test Class II, and are intended to be installed in indoor applications with a degree of protection rated IP 00.

The SPD delta and wye models are intended for use with a 3 phase TN-S system with PE and neutral distribution, 5 conductor with a minimum 10 AWG or 6 mm². The delta models are also intended for use with a 3 phase TN-C system with PEN distribution, 4 conductor with a minimum 10 AWG or 6mm².

Screws used for connection to ground shall be #10-32 x 3/8" and shall not be zinc or aluminum. This product is not serviceable and contains no replaceable parts.

Additional product information and ratings for IEC applications:

- The SPD contains internal disconnects with a short circuit current rating I_{SCCR} of 200kA.
- Residual current IPE for this product is 5 mA.
- Operating temperature is normal -5°C to 40°C (23°F to 104°F).
- Humidity range is 5% through 95% non-condensing.
- The SPD may be mounted directly to earthed conductive surface, installed as per this manual.
- Temporary overvoltage rating UT = 402.6 V.
- Withstand or safe failure mode, for tT = 120 minutes, UT = 526 V.
- Modes of protection as marked on a wye SPD = L - L, L - N, L - G(PE), N - G(PE).
- Modes of protection as marked on a delta SPD = L - L, L - G(PE).

9.0 Troubleshooting

Many SPD failures result from improper installation. Once the SPD is installed properly, it is a highly reliable unit.

If the SPD does not function properly, first confirm that it is installed properly. See Section 2, "Installation."

If the SPD malfunctions after it has been operating routinely, refer to Table 6. This troubleshooting chart identifies possible causes and solutions to the malfunction. Further assistance may be obtained by calling Eaton's Applications Engineers, at 1-800-809-2772 or email SPD@eaton.com, including being directed to the warranty process if applicable.

Table 6. Troubleshooting chart for feature packages 1, 2 and 3

Condition	Probable cause	Solution
Green LEDs ON (1 per phase) and one green LED ON for neu/gnd protection	Normal operation.	N/A.
Audible alarm OFF, form C (N.C.) contact in the CLOSED state	Normal operation.	N/A.
Phase green LED is OFF, same phase red LED is ON, audible alarm is ON.	Phase protection compromised or lost .	Replace SPD.
	Extended temporary overvoltage (TOV).	Check electrical system for TOV sources, correct, replace SPD.
	Significant surge event.	Replace SPD.
Neu/gnd green LED is OFF, neu/gnd red LED is ON, audible alarm is ON (for models with neutral connections).	Neu/gnd protection is compromised or lost.	Replace SPD.
	Significant surge event.	Replace SPD.
All phase green LEDs OFF, all phase red LEDs ON, audible alarm is ON.	All phase protection is compromised or lost.	Replace SPD.
	SPD rated voltage is less than system voltage.	Replace SPD with correct voltage model.
	Extended temporary overvoltage (TOV).	Check electrical system for TOV sources, correct, replace SPD.
	Significant surge event.	Replace SPD.
One of the display red LEDs is ON. audible alarm is OFF.	Audible alarm silence button has been depressed and alarm is silenced.	Normal operation
		If power is cycled and a fault condition still exists, the audible alarm will reactivate.
All green and red LEDs are OFF, LCD display (on Surge Counter models) is OFF.	SPD is not connected to a power source.	Check system voltage at SPD connection.
		Check SPD connections.
One phase has neither a green or red LED lit.	Ribbon cable is not connected properly. Ribbon cable is mis-aligned with connector.	Verify ribbon cable and connector are properly aligned and fully seated together.
All phase LEDs are green, audible alarm is on.	Insufficient voltage to the power supply.	Replace SPD.

10.0 Troubleshooting the Power Xpert SPD

Many SPD failures result from improper installation. Once the Power Xpert SPD is installed properly, it is a highly reliable unit.

If the SPD does not function properly, first confirm that it is installed properly. See Section 2, "Installation."

If the SPD malfunctions after it has been operating routinely, refer to Table 7. This troubleshooting chart identifies possible causes and solutions to the malfunction. Further assistance may be obtained by calling Eaton's Applications Engineers, at 1-800-809-2772 or email SPD@eaton.com, including being directed to the warranty process if applicable.

Table 7. Troubleshooting chart for Power Xpert SPD

Condition	Probable cause	Solution
Phase LEDs are green (1 per phase) and neu/gnd LED is green.	Normal operation.	N/A.
Audible alarm OFF, form C (N.C.) contact in the CLOSED state.	Normal operation.	N/A.
One phase LED is red, audible alarm is ON .	Phase protection compromised or lost.	Replace SPD.
	Extended temporary overvoltage (TOV).	Check electrical system for TOV sources, correct, replace SPD.
	Significant surge event.	Replace SPD.
Neu/gnd LED is red, audible alarm is ON (for models with neutral connections).	Neu/gnd protection is compromised or lost.	Replace SPD.
	Significant surge event.	Replace SPD.
All phase LEDs are red, audible alarm is ON.	All phase protection has been lost.	Replace SPD .
	SPD rated voltage is less than system voltage.	Replace SPD with correct voltage model.
	Extended temporary overvoltage (TOV).	Check electrical system for TOV sources, correct, replace SPD.
	Significant surge event	Replace SPD.
One of the display LEDs is red. audible alarm is OFF.	Audible alarm silence button has been depressed and Alarm is silenced.	Normal operation
		If power is cycled and a fault condition still exists, the audible alarm will reactivate. Replace SPD.
All LEDs are OFF, LCD display is OFF.	SPD is not connected to a power source.	Check system voltage at SPD connection.
		Check SPD connections.
One or more phase LED is yellow and neu/gnd LED is green.	SPD has lost some protection on the phase with the yellow LED.	Monitor SPD, some protection has been lost.
Surge counts are accumulating rapidly.	Noise on phase line.	Contact an Eaton Customer Support at 1-800-809-2772 or email SPD@eaton.com.
Stuck button error on the local display.	One or more of the buttons were depressing during startup.	Clear buttons of any obstructions, if that doesn't resolve the matter contact Eaton Customer Support at 1-800-809-2772 or email SPD@eaton.com.
LCD is turning off/on and there is no communication.	Insufficient input voltage.	Verify phase voltages are within tolerances.
Error "Web page not working".	Available TCP connection limit reached.	Close excess webpage tabs or applications attempting to access port.
BACnet port not communicating.	BACnet setting disabled (default).	Enable BACnet and reboot device.
Modbus port no communicating.	Modbus setting disabled (default).	Enable Modbus and reboot device.
Webpage not secure notice.	Security certificate not installed.	Download and install certificate.
Web UI surge and general logs will not load	Modbus disabled.	Enable Modbus and reboot device.
Time stamps inaccurate.	Clock not synced. Supercap drained of power during extended power loss.	Set clock and use SNTP feature to maintain accurate time stamp.
Any LCD communication setting 'save' initiates a soft reset.	All communication settings modifications require reboot to enable.	Must re-enter settings menu each time a communication setting is changed.

11.0 Specifications

Table 8. Specifications

Description	Specification
Surge current capacity per phase	50, 80, 100, 120, 160, 200, 250, 300, 400 kA ratings available
Nominal discharge current (In)	20kA
Short circuit current rating (SCCR)	200kA
SPD type	Basic feature package = type 1 (can also be used in type 2 applications) Standard, Standard with Surge Counter, and Power Xpert SPD feature packages = type 2
Standard split phase voltages available	120/240
Single phase	230
Three phase wye system voltages available	120/208, 127/220, 230/400, 277/480, 347/600
Three phase delta system voltages	240, 480, 600
Three phase high leg delta system voltages	120/240
Input power frequency	50/60 Hz, Power Xpert SPD tested to 60 Hz only
Power consumption (Basic units)	
208Y, 220Y, 230L, 240S, 240D, and 240H voltage codes	0.5 W
400Y and 480Y and 480D voltage codes	1.1 W
600Y and 600D voltage codes	1.3 W
Power consumption (Standard and Standard with Surge Counter units)	
208Y, 220Y, 230L, 240S, 240D, and 240H voltage codes	0.6 W
400Y, 480Y, and 480D Basic voltage codes	1.7 W
600Y and 600D voltage codes	2.1 W
Power consumption (Power Xpert SPD units)	
208Y, 220Y, 230L, 240S, 240D, and 240H voltage codes	4 W
400Y, 480Y, and 480D voltage codes	4 W
600Y and 600D voltage codes	4 W
Phase protection	
208Y, 220Y, 230L, 240S, 240D, and 240H voltage codes	Single split phaseL-N, L-G, N-G, L-L
400Y, 480Y, and 480D voltage codes	Single phaseL-N, L-G, N-G
600Y and 600D voltage codes	Three phase wye..... L-N, L-G, N-G, L-L
	Three phase delta.....L-G, L-L
	Three phase high leg delta.....L-N, L-G, N-G, L-L, H-N, H-G, H-L
Maximum continuous operating voltage (MCOV)	
208Y, 220Y, 230L, 240S voltage codes	150 L-N, 300 L-G, 150 N-G, 300 L-L
230L,	320 L-N, 640 L-G, 320 N-G
240H	150 L-N, 300 L-G, 150 N-G, 300 L-L, 320 H-N, 470 H-G, 470 H-L
400 and 480Y voltage codes	320 L-N, 640 L-G, 320 N-G, 640 L-L
600Y	420 L-N, 420 L-G, 420 N-G, 840 L-L
240D	300L- L-G, 300 L-L
480D	640 L-G, 640 L-L
600D	840 L-G, 840 L-L
Ports	1
Operating temperature	-40° C to 50° C (-40 F to 122° F), Power Xpert Surge protection (-40° C to 50° C), Power Xpert LCD module (-20° C to 70° C)
Operating humidity	5% through 95%, non-condensing
Operating altitude	Up to 16,000 ft (5000 m) Power Xpert SPD up to 6561 ft (2000 m)
Seismic withstand capability	Meets or exceeds the requirements specified in the IBC® 2018, CBC 2007, and UBC® Zone 4
Weight	50-200kA - approximately 1.6 kg (3.5 lbs) – 250 - 400kA - approximately 3.2kg (7.0 lbs)
Form C relay contact ratings	150 Vac at 0.46A, 30Vdc at 1A, terminal block connector rated 300V, 16A suitable for use with 30-12 AWG solid or stranded copper wire. Torque 5-7 lbs-in.
Form C relay contact logic	Power on, normal state - NO contact = OPEN, NC contact = CLOSED Power off, fault state, - NO contact = CLOSED, NC contact = OPEN
Real time clock accuracy, Power Xpert SPD	synchronized when connected to a network via an ethernet cable, +/- 2 min/month @ 25°C when not connected to a network

Table 8. Specifications (cont.)

Description	Specification
EMI/RFI filtering attenuation (Standard and Standard with Surge Counter, and Power Xpert SPD.	Up to 50 dB from 10 kHz to 100 MHz
Ethernet port	Data rate 100/10 Mbps, wire type: equal or exceed 5 UTP category 5, use of STP (shielded twisted pair) will improve EMI performance. Connector type: RJ45 modular, ground metal shield
Agency certifications and approvals	UL 1449 Standard for surge protective devices- edition 4 - revision date 2018/08/01, UL 1283 Standard for electromagnetic interference filters- edition 7 - revision date 2018/06/05, CSA C22.2 NO. 269.2-17 Surge protective devices - type 2 - permanently connected - edition 2 - issue date 2017/02/01, CSA C22.2 NO. 269.4-17 Surge protective devices - type 4 - component assemblies- edition 2 - issue date 2017/03/01, CSA C22.2 NO. 8-13 Electromagnetic interference (EMI) filters- edition 5 - issue date 2013/11/01, CSA C22.2 NO. 60950-1-07 + AMD 1 AMD 2 Information technology equipment -- safety. PT. 1, general requirements- edition 2 - revision date 2014/10/14, UL 60950-1+ AMD 1 AMD 2 Information technology equipment -- safety. PT. 1, general requirements- edition 2 - revision date 2019/05/09. ICES and FCC part 15 subpart B Conducted & Radiated Emissions Class A Limits Tested to UL2900-1, Software Cybersecurity for Network-connected Products, in Eaton's Cybersecurity test lab. IEC 255-21-1 and IEC 255-21-2 IEEE 693-2018 IBC-2018
Warranty	10 years, 15 years if you register on www.eaton.com/spd and click the warranty registration icon.
UL 96A compliant	Yes
NFPA 780 compliant	Yes *Certain models only, email SPD@eaton.com for additional information.
ROHS compliant	Yes
Wire length and AWG	Factory prewired with 18 inches of #10 AWG wire for mounting suffix B, C, and J.

12.0 Ordering guidelines

Table 9. Eaton SPD Series

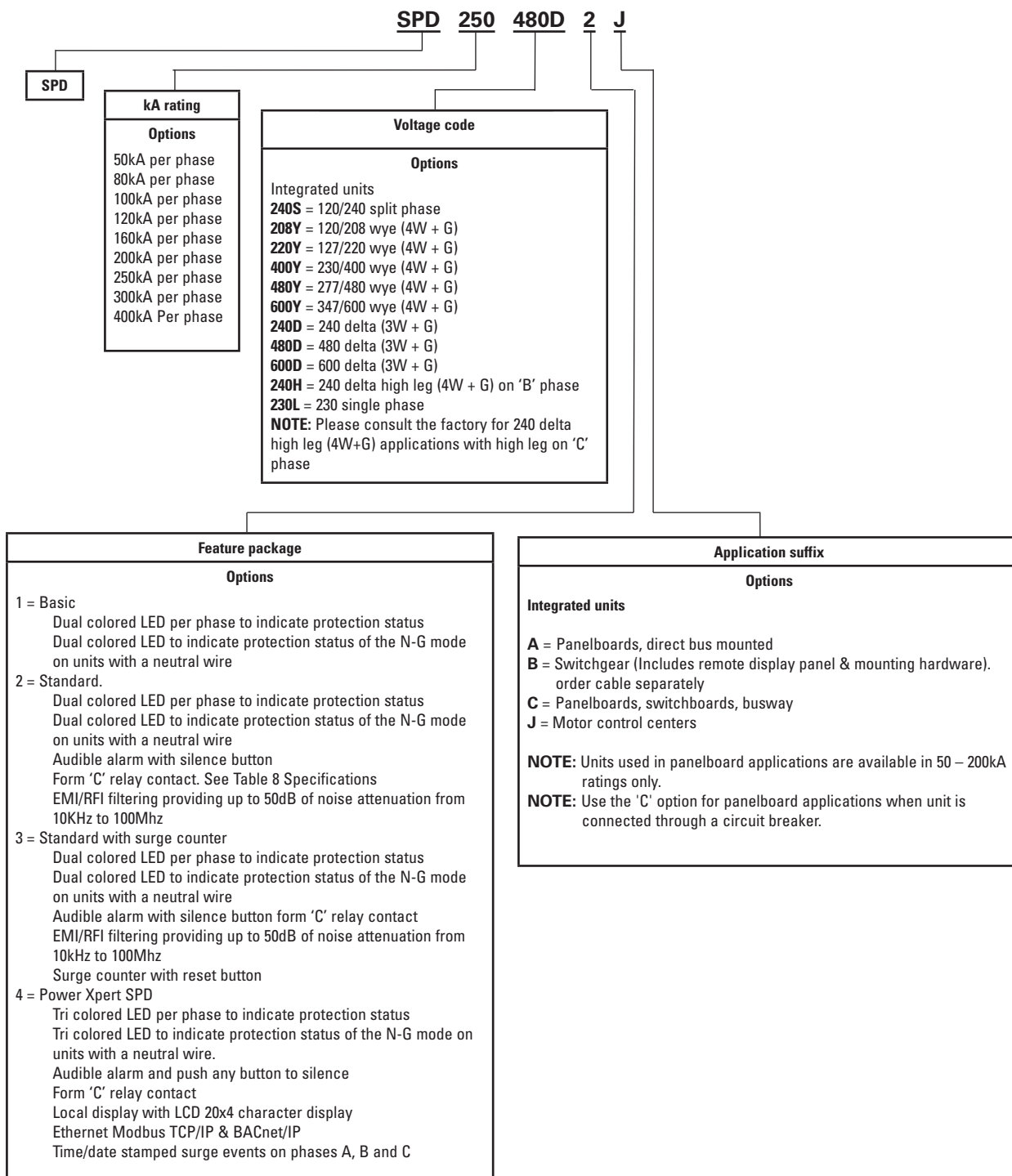

** Eaton's wye catalog numbers SPD120480Y2C, SPD160480Y2C, and SPD200480Y2C and Eaton's delta catalog numbers SPD120480D2C, SPD160480D2C, and SPD200480D2C meet the requirements of IEC 61643-11/EN 61643-11, part 11: test class II, and intended to be installed in indoor applications with a degree of protection rated IP 00.

Example: SPD 250480D2J = SPD series, 250kA per phase, 480D voltage, standard feature package, motor control center application.

13.0 Warranty

Eaton warrants these products for a period of 10 years from the date of delivery to the purchaser, 15 years if you register on www.eaton.com/spd and click the warranty registration icon to be free from defects in both workmanship and materials. Eaton assumes no risk or liability for results of the use of the products purchased from it, including but without limiting the generality of the foregoing:

- (1) The use in combination with any electrical or electronic components, circuits, systems, assemblies, or any other materials or substances;
- (2) Unsuitability of any product for use in any circuit or assembly.

Purchaser's rights under the warranty shall consist solely of requiring Eaton to repair, or at Eaton's sole discretion, replace, free of charge, F.O.B. factory, and defective items received at said factory within said term determined by Eaton to be defective. The giving of or failure to give any advice or recommendations by Eaton shall not constitute any warranty by or impose any liability upon Eaton. The foregoing constitutes the sole and exclusive liability of Eaton AND IS IN LIEU OF ANY AND ALL OTHER WARRANTIES EXPRESSED, IMPLIED OR STATUTORY AS TO THE MERCHANTABILITY, FITNESS FOR PURPOSE SOLD, DESCRIPTION, QUALITY, PRODUCTIVENESS OR ANY OTHER MATTER.

In no event shall Eaton be liable for special or consequential damages or for delay in performance of the warranty.

This warranty does not apply if the product has been misused, abused, altered, tampered with, or used in applications other than specified on the nameplate. At the end of the warranty period, Eaton shall be under no further warranty obligation expressed or implied.

The product covered by this warranty certificate can only be repaired or replaced by the factory. For help on troubleshooting the SPD, or for warranty information, call 1-800-809-2772 or email SPD@eaton.com. Repair or replacement units will be returned collect. If Eaton finds the return to be a manufacturer's defect, the product will be returned prepaid.

Copyright © 2013 by Eaton, Moon Township, PA, USA. All rights reserved. No part of this document may be reproduced in any way without the express written approval of Eaton.

Specifications contained herein are subject to change without notice.

EATON - CONFIDENTIAL AND PROPRIETARY NOTICE TO PERSONS RECEIVING THIS DOCUMENT AND/OR TECHNICAL INFORMATION IN THIS DOCUMENT, INCLUDING THE DRAWING AND INFORMATION CONTAINED THEREON, IS CONFIDENTIAL AND IS THE EXCLUSIVE PROPERTY OF EATON, AND IS MERELY ON LOAN AND SUBJECT TO RECALL BY EATON AT ANY TIME. BY TAKING POSSESSION OF THIS DOCUMENT, THE RECIPIENT ACKNOWLEDGES AND AGREES THAT THIS DOCUMENT CANNOT BE USED IN ANY MANNER ADVERSE TO THE INTERESTS OF EATON, AND THAT NO PORTION OF THIS DOCUMENT MAY BE COPIED OR OTHERWISE REPRODUCED WITHOUT THE PRIOR WRITTEN CONSENT OF EATON. IN THE CASE OF CONFLICTING CONTRACTUAL PROVISIONS, THIS NOTICE SHALL GOVERN THE STATUS OF THIS DOCUMENT.

DISCLAIMER OF WARRANTIES AND LIMITATION OF LIABILITY

The information, recommendations, descriptions and safety notations in this document are based on Eaton's ("Eaton") experience and judgment and may not cover all contingencies. If further information is required, an Eaton sales office should be consulted. Sale of the product shown in this literature is subject to the terms and conditions outlined in appropriate Eaton selling policies or other contractual agreement between Eaton and the purchaser. THERE ARE NO UNDERSTANDINGS, AGREEMENTS, WARRANTIES, EXPRESSED OR IMPLIED, INCLUDING WARRANTIES OF FITNESS FOR A PARTICULAR PURPOSE OR MERCHANTABILITY, OTHER THAN THOSE SPECIFICALLY SET OUT IN ANY EXISTING CONTRACT BETWEEN THE PARTIES. ANY SUCH CONTRACT STATES THE ENTIRE OBLIGATION OF EATON. THE CONTENTS OF THIS DOCUMENT SHALL NOT BECOME PART OF OR MODIFY ANY CONTRACT BETWEEN THE PARTIES.

In no event will Eaton be responsible to the purchaser or user in contract, in tort (including negligence), strict liability or otherwise for any special, indirect, incidental or consequential damage or loss whatsoever, including but not limited to damage or loss of use of equipment, plant or power system, cost of capital, loss of power, additional expenses in the use of existing power facilities, or claims against the purchaser or user by its customers resulting from the use of the information, recommendations and descriptions contained herein

Appendix A Power Xpert SPD local display surge events menu map

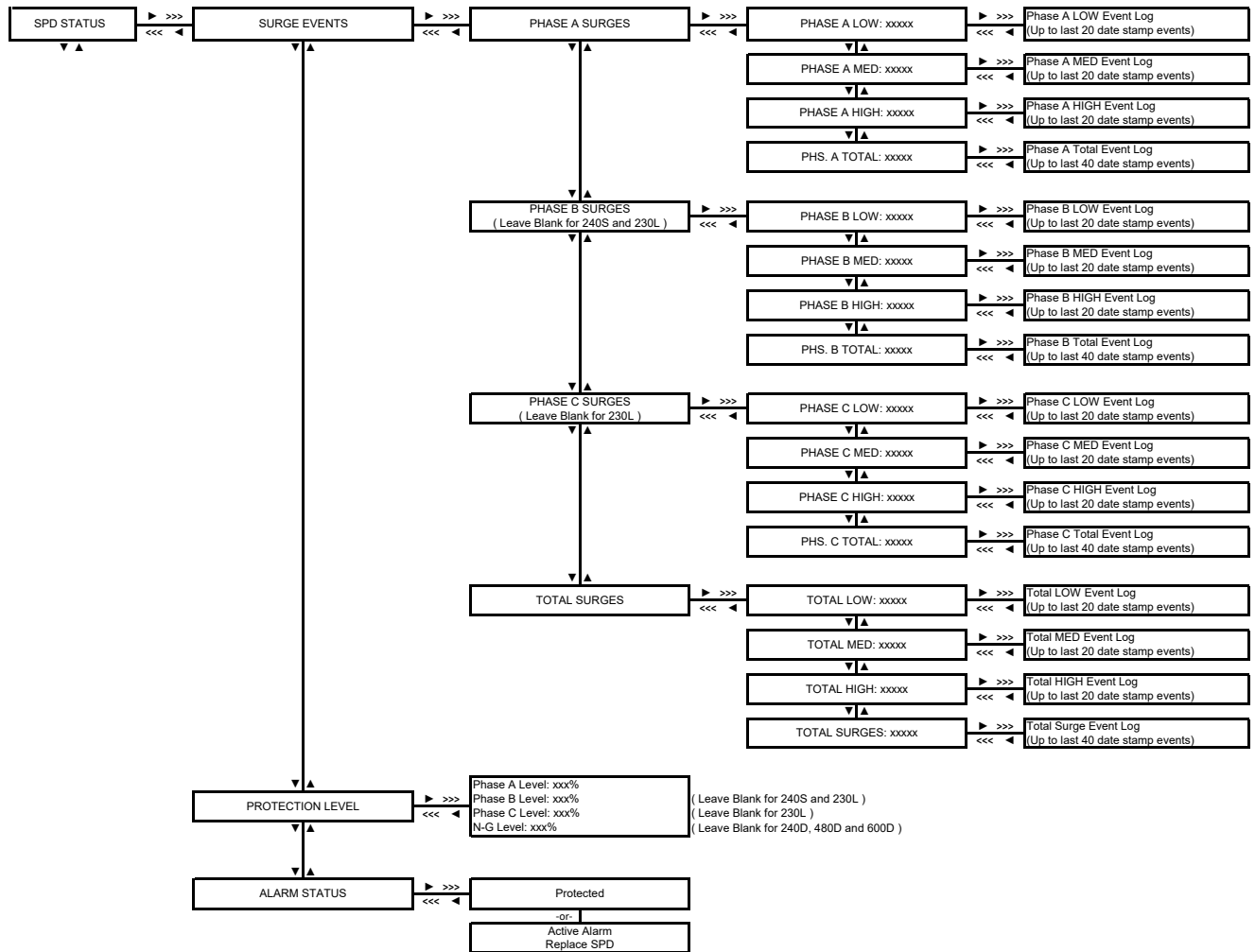

Appendix B Power Xpert SPD local display event log menu map

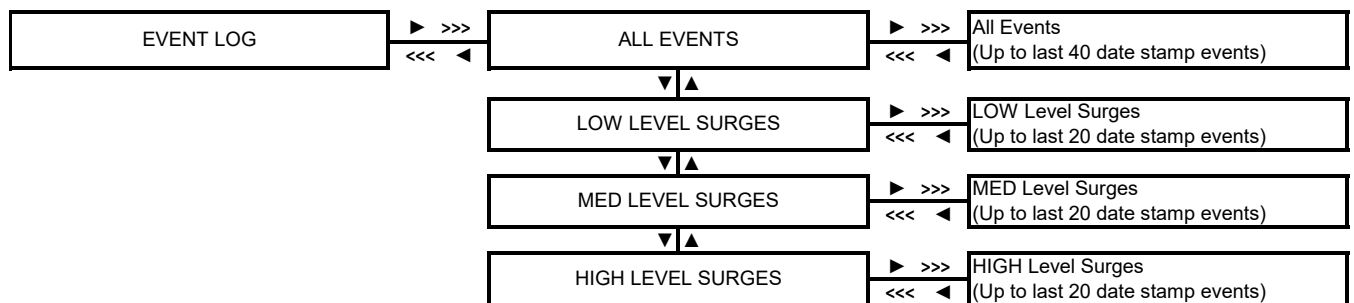

Appendix C Power Xpert SPD local display settings menu map

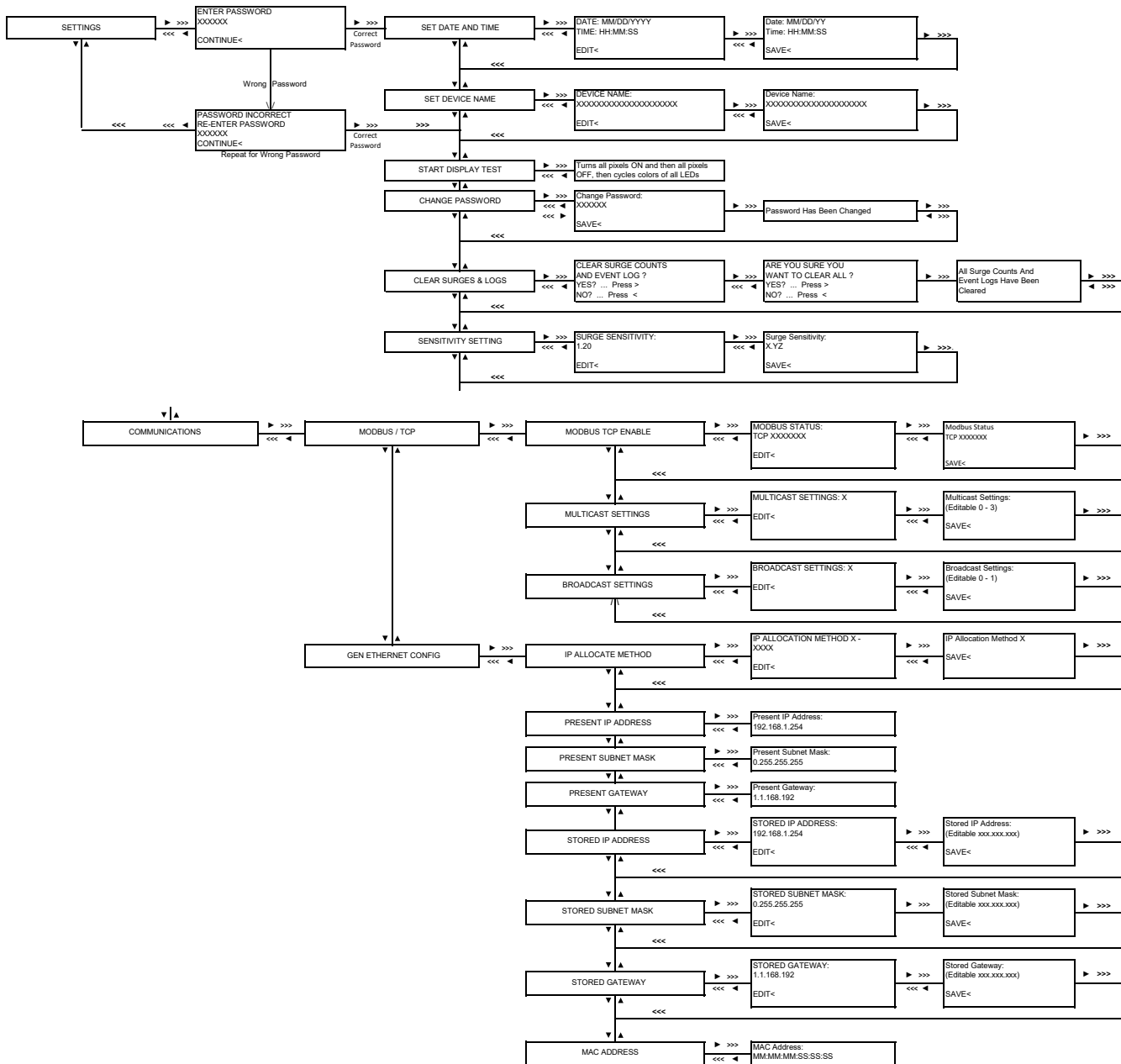

Appendix D
Power Xpert SPD local display identification menu map

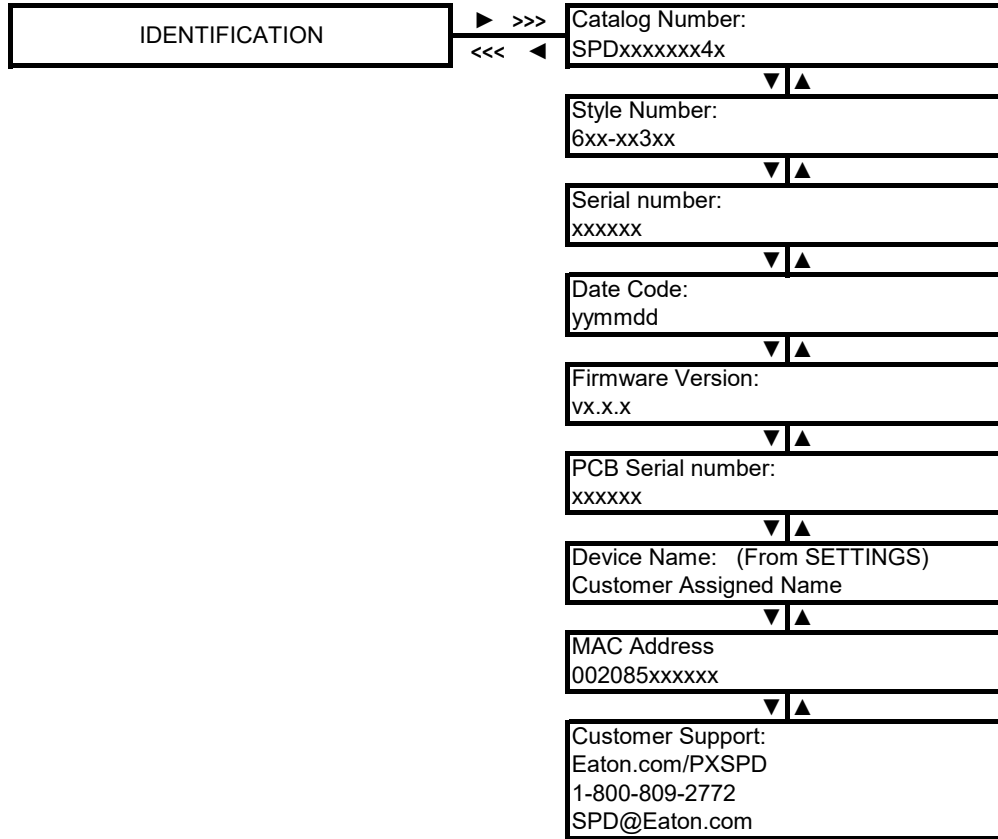

Appendix E Power Xpert SPD local display test sequence



1. All LEDs turn red



6. Half pixels turn on



2. All LEDs turn yellow



7. Other half of pixels turn on



3. All LEDs turn green



8. All pixels turn on



4. Alarm will sound momentarily.



9. LEDs turn red again.



5. Alarm turns off



10. Test completed

Appendix F Power Xpert SPD Modbus register map

Power Xpert SPD Modbus register map

Register	Name	Attributes	Description
1	Product Serial Number	UINT32 RO NV	32bit device serial number. (MAE)
3	Vendor Name	STRING8 RO Array size: 12	Product vendor name character string Array of 6 registers
14	Vendor URL	STRING8 RO Array size: 14	Product vendor URL Array of 7 registers
37	Style Number	STRING8 RO NV Array size: 10	Product style number (MAE) Array of 5 registers
42	Assigned Name	STRING8 RW NV Array size: 21 Default: "SPDLAB1"	User assigned name Array of 11 registers
53	Firmware Revision	STRING8 RO Array size: 14	Firmware revision Array of 7 registers
60	PCB Serial Number	STRING8 RO NV Array size: 14	Product hardware revision numerical (MAE) Array of 7 registers
77	Method of IP Allocation	UINT8 RW NV Default: 0 Enum	Allows to set the method used to allocate an IP address: 0 - restore (hardcoded 192.168.1.254). 1 - DHCP. 2 -full address taken from NV memory. Value Description 0 Statically hardcoded 1 DHCP allocated 2 Taken from NV
78	Current Method of IP Allocation	UINT8 RO Range: 0 to 3	Shows the present method used to allocate an IP address: 0 - restore (hardcoded 192.168.1.254). 1 - DHCP. 2 - full address taken from NV memory.
79	Present Ethernet IP Address	UINT8 RO Array size: 4 Units: IP	The active IP address being used on the network. Array of 2 registers IPV4_BIG_ENDIAN_U8()
81	Present Ethernet Subnet Mask	UINT8 RO Array size: 4 Units: IP	The active subnet mask IP address being used on the network. Array of 2 registers IPV4_BIG_ENDIAN_U8()
83	Present Ethernet Default Gateway	UINT8 RO Array size: 4 Units: IP	The active default gateway IP address being used on the network. Array of 2 registers IPV4_BIG_ENDIAN_U8()
85	Stored Ethernet IP Address	UINT8 RW NV Array size: 4 Default: 0xFE, 0x01, 0xA8, 0xC0 Units: IP	The IP address used in the NV address select configuration. Array of 2 registers IPV4_BIG_ENDIAN_U8()
87	Stored Ethernet Subnet Mask	UINT8 RW NV Array size: 4 Default: 0x00, 0xFF, 0xFF, 0xFF Units: IP	The IP subnet mask used in the NV address select configuration. Array of 2 registers IPV4_BIG_ENDIAN_U8()
89	Stored Ethernet Default Gateway	UINT8 RW NV Array size: 4 Default: 0x01, 0x01, 0xA8, 0xC0 Units: IP	The IP default gateway used in the NV address select configuration. Array of 2 registers IPV4_BIG_ENDIAN_U8()
98	Multicast Enable Disable (00000010)	UINT32 RW NV Default: 0x00000010	Multicast settings: Value : Description 0x00000010: Multicast Enable 0x00000000: Multicast Disable with Filter PerfectFilter 0x00000004: Multicast Disable with Filter HashTable 0x00000404: Multicast Disable with Filter_PerfectHashTable
100	Broadcast Enable Disable (0)	UINT32 RW NV	Broadcast Enable Disable settings: 0x00000000: BroadcastFramesReception_Enable 0x00000020: BroadcastFramesReception_Disable
102	Modbus TCP Com Timeout (0)	UINT16 RW NV Default: 0 Units: milliseconds	Communication timeout for Modbus TCP. 0 = disable.

Power Xpert SPD Modbus register map (cont.)

Register	Name	Attributes	Description
122	DHCP to Static IP addr lock (0)	BOOL RW NV Default: FALSE Range: FALSE to TRUE	
127	Set Time	UINT32 RW Default: 946684800	32 bit epoch time from RTC
129	RTC Time	UINT32 RO Default: 0x0034220A	Real time clock time in hh:mm:ss format (24 hour format)
187	Sensitivity	UINT8 RW NV Default: 25 Range: 25 to 50	Threshold value for considering the valid low surge count should be in the range of 1.00 to 2.00 for Local Display. Threshold value for Modbus is 25=1.00 to 50=2.00.
188	Phase A High Surge Count	UINT32 RO Default: 0 Range: 0 to 99999	Number of high surge occurred in phase A
190	Phase A Medium Surge Count	UINT32 RO Default: 0 Range: 0 to 99999	Number of medium surge occurred in phase A
192	Phase A Low Surge Count	UINT32 RO Default: 0 Range: 0 to 99999	Number of low surge occurred in phase A
194	Phase B High Surge Count	UINT32 RO Default: 0 Range: 0 to 99999	Number of high surge occurred in phase B
196	Phase B Medium Surge Count	UINT32 RO Default: 0 Range: 0 to 99999	Number of medium surge occurred in phase B
198	Phase B Low Surge Count	UINT32 RO Default: 0 Range: 0 to 99999	Number of low surge occurred in phase B
200	Phase C High Surge Count	UINT32 RO Default: 0 Range: 0 to 99999	Number of high surge occurred in phase C
202	Phase C Medium Surge Count	UINT32 RO Default: 0 Range: 0 to 99999	Number of medium surge occurred in phase C
204	Phase C Low Surge Count	UINT32 RO Default: 0 Range: 0 to 99999	Number of low surge occurred in phase C
206	Low Surge Event Time Stamp	UINT32 RO Array size: 2000 Default: 0	Stores the timestamp of low surge event. Timestamp will be stored in epoch time. Time stamp can be verified using register 123 Array of 4000 registers
4206	Low Surge Event Phase Indicator	UINT8 RO Array size: 2000 Default: 0 Enum	Indicates in which the phase, low surge event occurred. Value Description 1 Phase A low surge event log 2 Phase B low surge event log 3 Phase C low surge event log
5206	Low Surge Event Log Index	UINT16 RO Default: 0 Range: 0 to 2000	Index points to the latest low surge event log
5207	Medium Surge Event Time Stamp	UINT32 RO Array size: 1500 Default: 0	Stores the timestamp of medium surge event. Timestamp will be stored in epoch time. Array of 3000 registers

Power Xpert SPD Modbus register map (cont.)

Register	Name	Attributes	Description
8207	Medium Surge Event Phase Indicator	UINT8 RO	Indicates in which the phase, medium surge event occurred.
		Array size: 1500	Value Description
		Default: 0	1 Phase A medium surge event log
		Enum	2 Phase B medium surge event log
			3 Phase C medium surge event log
8957	Medium Surge Event Log Index	UINT16 RO	Index points to the latest medium surge event log
		Default: 0	
		Range: 0 to 1500	
8958	High Surge Event Time Stamp	UINT32 RO	Stores the timestamp of high surge event. Timestamp will be stored in epoch time
		Array size: 1000	Array of 2000 registers
		Default: 0	
10958	High Surge Event Phase Indicator	UINT8 RO	Indicates in which the phase, medium surge event occurred.
		Array size: 1000	Value Description
		Default: 0	1 Phase A high surge event log
		Enum	2 Phase B high surge event log
			3 Phase C high surge event log
11458	High Surge Event Log Index	UINT16 RO	Index points to the latest high surge event log
		Default: 0	
		Range: 0 to 1000	
11459	Clear Surge Log Events	BOOL RW NV	Clear the high, medium and low surge event logs in phase A, B and C 1. Default value is zero 2. Writing 1 to the register will clear the surge logs.
		Default: 0	
		Range: 0 to 1	
11460	Clear Surge Counts	BOOL RW NV	Clear the high, medium and low surge counts in phase A, B and C 1. Default value is zero 2. Writing 1 to the register will clear the surge counts.
		Default: 0	
		Range: 0 to 1	
11461	Indicates Power Xpert SPD System faults	DWORD RO	Power Xpert SPD system fault indication to user
		Default: 0	Bit Description Coil
		Bitfield	0 No faults n/a
			1 Error in logging data to FRAM n/a
			2 NV memory checksum error n/a
11463	Total Low Surge Counts	UINT32 RO	Indicates total low surges occurred. This will be sum of phase A, phase B and phase C low surge counts
		Default: 0	
		Range: 0 to 999999	
11465	Total Medium Surge Counts	UINT32 RO	Indicates total medium surges occurred. This will be sum of phase A, phase B and phase C medium surge counts
		Default: 0	
		Range: 0 to 999999	
11467	Total High Surge Counts	UINT32 RO	Indicates total high surges occurred. This will be sum of phase A, phase B and phase C high surge counts
		Default: 0	
		Range: 0 to 999999	
11469	Sum of Surge Counts of All Phases	UINT32 RO	Indicates the total surge counts, This will be sum of low, medium and high surges
		Default: 0	
		Range: 0 to 999999	
11476	Power Xpert SPD Firmware Version ASCII	STRING8 RO	Power Xpert SPD firmware in the format of major & minor.
		Array size: 6	Array of 3 registers
11479	Date Code	STRING8 RO NV	Date code as determined by test station, format : "yyymmdd". (MAE)
		Array size: 7	Array of 4 registers
11483	Catalog Number	STRING8 RO NV	Catalog number assigned to the product. (MAE)
		Array size: 20	Array of 10 registers
11497	Indicates the status of N-G Green LED	BOOL RO	Indicates the status of N-G green LED, 0:LED off 1:LED on. Indicates protection status on N-G
11498	Indicates the status of N-G Yellow LED	BOOL RO	Indicates the status of N-G yellow LED, 0:LED off 1:LED on. Indicates protection status on N-G

Power Xpert SPD Modbus register map (cont.)

Register	Name	Attributes	Description
11499	Indicates the status of N-G Red LED	BOOL RO Default: 0	Indicates the status of N-G red LED, 0:LED off 1:LED on. Indicates protection status on N-G
11500	Indicates the status of Phase A Green LED	BOOL RO Default: 0	Indicates the status of phase-A green LED, 0:Led off 1:LED on. Indicates protection status on phase-A
11501	Indicates the status of Phase A Yellow LED	BOOL RO Default: 0	Indicates the status of phase-A yellow LED, 0:LED off 1:LED on. Indicates protection status on phase-A
11502	Indicates the status of Phase A Red LED	BOOL RO Default: 0	Indicates the status of phase-A red LED, 0:LED off 1:LED on. Indicates protection status on phase-A
11503	Indicates the status of Phase B Green LED	BOOL RO Default: 0	Indicates the status of phase-B green LED, 0:LED off 1:LED on. Indicates protection status on phase-B
11504	Indicates the status of Phase B Yellow LED	BOOL RO Default: 0	Indicates the status of phase-B yellow LED, 0:LED off 1:LED on. Indicates protection status on phase-B
11505	Indicates the status of Phase B Red LED	BOOL RO Default: 0	Indicates the status of phase-B red LED, 0:LED off 1:LED on. Indicates protection status on phase-B
11506	Indicates the status of Phase C Green LED	BOOL RO Default: 0	Indicates the status of phase-C green LED, 0:LED off 1:LED on. Indicates protection status on phase-C
11507	Indicates the status of Phase C Yellow LED	BOOL RO Default: 0	Indicates the status of phase-C yellow LED, 0:LED off 1:LED on. Indicates protection status on phase-C
11508	Indicates the status of Phase C Red LED	BOOL RO Default: 0	Indicates the status of phase-C red LED, 0:LED off 1:LED on. Indicates protection status on phase-C
11509	Alarm status	UINT8 RO Default: 0	Power Xpert SPD alarm status, alarm is used to indicate protection status
		Enum	Value Description 0 Alarm OFF 1 Alarm ON
11510	Percentage of protection on N-G	UINT16 RO Default: 0	Percentage of protection available on NG
11511	Percentage of protection on Phase A	UINT16 RO Default: 0	Percentage of protection available on phase A
11512	Percentage of protection on Phase B	UINT16 RO Default: 0	Percentage of protection available on phase B
11513	Percentage of protection on Phase C	UINT16 RO Default: 0	Percentage of protection available on phase C
11514	Silences the Alarm. Setting the value, will silence the Alarm	BOOL RW Default: 0	Silences the Alarm. Setting the value, will silence the alarm
11515	Ambient temperature of SPD device	FLOAT RO Default: 0	Ambient temperature in Celsius
11517	General log Indicator	UINT16 RO Array size: 250 Default: 0	General log Indicator
		Enum	Value Description 0 No event occurred 1 Protection reduced on phase A 2 Protection reduced on phase B 3 Protection reduced on phase C 4 Protection reduced on neutral ground 5 Protection loss on phase A 6 Protection loss on phase B 7 Protection loss on phase C 8 Protection loss on phase neutral ground 9 Alarm silenced 10 SPD powered off 11 SPD powered on
11767	General log Timestamp	UINT32 RO Array size: 250 Default: 0	Stores the timestamp of general log events. Timestamp will be stored in epoch time. Time stamp can be verified using register 123. Array of 500 registers

Power Xpert SPD Modbus register map (cont.)

Register	Name	Attributes	Description
12267	General log Index	UINT16 RO Default: 0 Range: 0 to 250	Index points to the latest general event log
12268	Clear General Log Events	BOOL RW NV Default: 0 Range: 0 to 1	Clear general event logs 1. Default value is zero 2. Writing 1 to the register will clear the general logs.
12269	Phase A Total Surge Counts	UINT32 RO Default: 0 Range: 0 to 999999	Sum of phase A high, medium and low surge counts
12271	Phase B Total Surge Counts	UINT32 RO Default: 0 Range: 0 to 999999	Sum of phase B high, medium and low surge counts
12273	Phase C Total Surge Counts	UINT32 RO Default: 0 Range: 0 to 999999	Sum of phase C high, medium and low surge counts
12275	DCI for Testing Display	BOOL RW Default: 0 Range: 0 to 1	DCI test display, LED and alarm. Setting the value starts the display test, once the display test is complete the value will be updated to zero by the firmware
12276	Ethernet MAC Address	UINT8 RO NV Array size: 6	Unique MAC address assigned to this device.(MAE) Array of 3 registers MAC_ADDRESS()

Appendix G
Web user error codes

Error Message	Description	Action Required
Login Failed (Login Page)	User not authorized to access device	Contact administrator for authorization
One Admin Role is mandatory in System		
User Self-Deletion Not Permitted		Contact administrator to delete user
Username Already Exists	Username already exists on the device	Create unique username
User Database Full		
Password Security Violation		
Password Matches With Name or Existing Password	Username and password match	Create unique username and password
New password cannot match old password		
User Locked Temporarily	Too many users trying to access device	
HTTP Version Not Supported		
Failed to Fetch	Device communication failed (login page), device communication failure (firmware update page)	
Codepack integrity check has failed	Image in the codepack file is corrupt	Re-install firmware
Codepack integrity check has aborted firmware update	Displayed when any one image is corrupt during multiple firmware update	Re-install firmware
Final integrity check is invalid	Multiple reasons	

Appendix H BACnet map

Analog objects

Instance	Object name	Object description	Object type	Unit	Access type	COV increment
0	Sensitivity	Surge sensitivity	AV	No unit	R/W	1
1	Phase A High Surge Count	Phase A high surge count	AV	No unit	RO	1
2	Phase A Medium Surge Count	Phase A medium surge count	AV	No unit	RO	1
3	Phase A Low Surge Count	Phase A low surge count	AV	No unit	RO	1
4	Phase B High Surge Count	Phase B high surge count	AV	No unit	RO	1
5	Phase B Medium Surge Count	Phase B medium surge count	AV	No unit	RO	1
6	Phase B Low Surge Count	Phase B low surge count	AV	No unit	RO	1
7	Phase C High Surge Count	Phase C high surge count	AV	No unit	RO	1
8	Phase C Medium Surge Count	Phase C medium surge count	AV	No unit	RO	1
9	Phase C Low Surge Count	Phase C low surge count	AV	No unit	RO	1
10	Phase A % Protection	Percentage of protection available on phase A	AV	No unit	RO	1
11	Phase B % Protection	Percentage of protection available on phase B	AV	No unit	RO	1
12	Phase C % Protection	Percentage of protection available on phase C	AV	No unit	RO	1
13	Phase N-G % Protection	Percentage of protection available on NG	AV	No unit	RO	1
14	Phase A Total Surge Counts	Phase A total surge counts	AV	No unit	RO	1
15	Phase B Total Surge Counts	Phase B total surge counts	AV	No unit	RO	1
16	Phase C Total Surge Counts	Phase C total surge counts	AV	No unit	RO	1
17	RTC Time	RTC time	AV	No unit	RO	1
18	Set Time	Set time	AV	No unit	R/W	1
19	Total Low Surge Counts	Total low surge counts	AV	No unit	RO	1
20	Total Medium Surge Counts	Total medium surge counts	AV	No unit	RO	1
21	Total High Surge Counts	Total high surge counts	AV	No unit	RO	1
22	Total Surge Counts	Total surge counts	AV	No unit	RO	1
23	System Faults	System faults	AV	No unit	RO	1
24	Method of IP Allocation	Allows to set the method used to allocate an IP address	AV	No unit	R/W	1

Binary objects

Instance	Object name	Object description	Object type	Inactive text	Active text	Access type
0	Clear Surge Log Events	Clear surge log events	BV	OFF	ON	R/W
1	Clear Surge Counts	Clear surge counts	BV	OFF	ON	R/W
2	Phase A Green Led Status	Phase A green led status	BV	OFF	ON	RO
3	Phase A Yellow Led Status	Phase A yellow led status	BV	OFF	ON	RO
4	Phase A Red Led Status	Phase A red led status	BV	OFF	ON	RO
5	Phase B Green Led Status	Phase B green led status	BV	OFF	ON	RO
6	Phase B Yellow Led Status	Phase B yellow led status	BV	OFF	ON	RO
7	Phase B Red Led Status	Phase B red led status	BV	OFF	ON	RO
8	Phase C Green Led Status	Phase C green led status	BV	OFF	ON	RO
9	Phase C Yellow Led Status	Phase C yellow led status	BV	OFF	ON	RO
10	Phase C Red Led Status	Phase C red led status	BV	OFF	ON	RO
11	NG Green Led Status	NG green led status	BV	OFF	ON	RO
12	NG Yellow Led Status	NG yellow led status	BV	OFF	ON	RO
13	NG Red Led Status	NG red led status	BV	OFF	ON	RO
14	Alarm status	Alarm status	BV	Protected	Protection loss	RO
15	Silences Alarm	Silences the alarm	BV	Silence?	Silenced	R/W
16	Clear General Log	Clear general log	BV	OFF	ON	R/W

AV = Analog Value
BV = Binary Value

Appendix H BACnet map (Cont.)

Device objects

Object name	Object type	Access type
Product Vendor Name	DEV	RO
BACnet Vendor Identifier	DEV	RO
Style Name	DEV	RO
BACnet Max Master	DEV	RO
BACnet Max Info Frames	DEV	RO
BACnet Profile Name	DEV	RO
User Application Name or Device Tag	DEV	RO
Product Name - Short description of Prod Code	DEV	RO

Eaton
Electrical Sector
1000 Eaton Boulevard
Cleveland OH 44122
United States
1-800-809-2772 or email SPD@eaton.com
Eaton.com

© 2021 Eaton
All Rights Reserved
Printed in USA
Publication No. IM01005019E TBG000335
March 2021

Eaton is a registered trademark.

All other trademarks are property of their respective owners.

The Eaton logo consists of the word "EATON" in a bold, blue, sans-serif font. The letter "O" is stylized as a white circle with a blue dot in the center, creating a circular graphic element.

Powering Business Worldwide

Eaton SPD Series

for mounting external to electrical distribution equipment



Contents

Description	Page
1.0 Introduction	2
2.0 Installation	3
3.0 Operating features	9
4.0 Power Xpert SPD display menu	11
5.0 Power Xpert SPD user setup	12
6.0 SPD display rotation	21
7.0 IEC approved models	21
8.0 Troubleshooting	22
9.0 Trouble shooting PX-SPD	23
10.0 Specifications	24
11.0 Ordering guidelines	26
12.0 Warranty	27

Description	Page
Appendix A Power Xpert SPD local display menu map - surge events	28
Appendix B Power Xpert SPD local display menu map - event log	28
Appendix C Power Xpert SPD local display menu map - settings	29
Appendix D Power Xpert SPD local display menu map - identification	30
Appendix E Power Xpert SPD local display - test sequence	31
Appendix F: Power Xpert SPD Modbus register map	32
Appendix G Web user error codes	36
Appendix H BACnet map	37

For additional information on the new PX-SPD go to www.eaton.com/pxspd



1.0 Introduction

Product overview

This installation manual describes the safe installation, testing and operation of the Eaton® SPD Series surge protective device (SPD).

The Eaton SPD Series protects critical electrical and electronic equipment from damage by power surges. This is done by shunting high energy lightning surges (and other transient disturbances) away from the equipment being protected. It does this in nanoseconds by providing a low impedance surge path to ground while supporting power frequency voltage.

The Eaton SPD Series is designed to mount on the wall (or other vertical surface) as close as possible to the electrical cabinet. The SPD Series is available in voltage ratings from 120-600V AC, surge current capacity ratings from 50kA to 400kA, and NEMA 1, NEMA 4 or NEMA 4X enclosures.

The Eaton SPD Series is available in four feature packages (Basic, Standard, Standard with Surge Counter, and Power Xpert SPD) as described in Section 3, "Operating features". Each model is available in delta, wye, single phase and split phase wiring configurations.

All Eaton SPD Series models have been tested and certified by Underwriter's Laboratory (UL®), to comply with UL Standard 1449, 4th Edition.

Eaton's one-port low-voltage surge protective device delta models **SPD120480D3M**, **SPD160480D3M** and **SPD200480D3M** meet the requirements of IEC 61643-11 / EN 61643-11, Part 11: Test Class II, and are intended to be installed in applications with a degree of protection rated IP 20.

Safety precautions

⚠️WARNING

WARNING – SHOCK HAZARD – DO NOT OPEN. AVERTISSEMENT: RISQUE DE DECHARGE ELECTRIQUE – NE PAS OUVRIR.

WARNING NO SERVICEABLE PARTS. ATTENTION: AUCUNE PIÈCE REMPLACABLE OU RÉPARABLE

A LICENSED/QUALIFIED ELECTRICIAN MUST COMPLETE ALL INSTRUCTIONS IN THIS MANUAL IN ACCORDANCE WITH THE NATIONAL ELECTRIC CODE (NEC®), STATE, AND LOCAL CODES, OR OTHER APPLICABLE COUNTRY CODES. ALL APPLICABLE LOCAL ELECTRICAL CODES SUPERSEDE THESE INSTRUCTIONS.

IMPROPER INSTALLATION COULD CAUSE DEATH, INJURY AND EQUIPMENT DAMAGE. FOLLOW ALL WARNINGS AND CAUTIONS. COMPLETELY READ AND UNDERSTAND THE INFORMATION IN THIS INSTRUCTION MANUAL BEFORE ATTEMPTING TO INSTALL OR OPERATE THIS EQUIPMENT.

ARC FLASH DURING INSTALLATION COULD CAUSE INJURY OR DEATH. USE APPROPRIATE SAFETY PRECAUTIONS, PPE AND EQUIPMENT FOR ARC FLASH PROTECTION.

INSTALLING A PROTECTION DEVICE WHICH IS UNDER RATED FOR THE ELECTRICAL SYSTEM VOLTAGE CAN CREATE A POTENTIALLY HAZARDOUS CONDITION.

CHECK THE FACILITY'S GROUNDING SYSTEM. ALL GROUNDING, BONDING AND EARTHING PRACTICES MUST MEET NEC, CEC AND LOCAL APPROVED PRACTICES. A POOR GROUND, OR A GROUNDING / BONDING VIOLATION WILL SERIOUSLY AFFECT THE SPD'S ABILITY TO FUNCTION AS SPECIFIED.

⚠️WARNING

FOR USE ON CIRCUITS DELIVERING UP TO 200,000 RMS AMPS. CONVIENT À DES CIRCUITS PRODUISANT AU PLUS 200,000 A EFF.

ALWAYS VERIFY THAT NO VOLTAGE IS PRESENT BEFORE PROCEEDING WITH THE TASK AND ALWAYS FOLLOW ALL SAFETY PROCEDURES.

HAZARDOUS VOLTAGES ARE PRESENT INSIDE THE SPD DURING NORMAL OPERATION. FOLLOW ALL SAFE WORK PRACTICES TO AVOID ELECTRICAL SHOCK.

1.4 Catalog numbering system

Each Eaton SPD Series unit has a name plate that identifies the parameters used for manufacture. These parameters are expressed in letters and numbers, to reflect the series, kA rating, voltage code, feature package, and application as shown in Table 1.

Table 1. Catalog numbering system

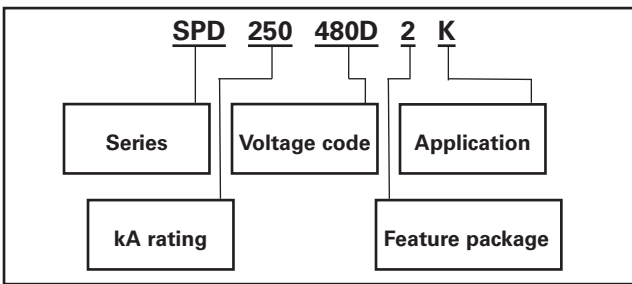

For example, a 480 volt delta (3-wire plus ground) for use in a NEMA 1 application requires an SPD model SPD 250480D2K, where:

SPD = SPD model,

250 = the kA rating (50 – 400 kA),

480D = the voltage and phase wiring configuration,

2 = the feature package (Basic, Standard, Standard with Surge Counter, or Power Xpert SPD), and,

K = the application suffix (such as NEMA 1 or NEMA 4 with internal disconnect).

The catalog number is the model number. on the product label as shown below, which is attached to the SPD. See Figure 1.

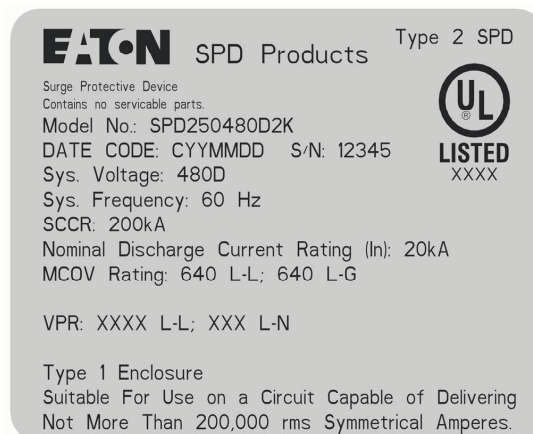

Figure 1. Product label

Equipment testing

⚠WARNING

CONDUCTING DIELECTRIC, MEGGER, OR HI-POTENTIAL TESTING WITH THE SPD INSTALLED WILL CAUSE INTERNAL DAMAGE TO THE SPD. THE SPD WILL ALSO CAUSE THE TEST TO FAIL.

Every Eaton SPD Series unit is tested at the factory for dielectric breakdown. No further SPD testing is required for installation.

If you desire to test distribution equipment by performing dielectric, megger, or hi-potential tests, any installed SPD **must** be disconnected from the power distribution system to prevent damage to the unit.

For SPDs connected to a circuit breaker or fuse:

For 3-wire delta SPDs: Turn off the circuit breaker or remove the fuses from the fuse holder to isolate the SPD.

For wye and split phase SPDs: Turn off the circuit breaker or remove the fuses from the fuse holder to isolate the SPD and remove the neutral connection on wye connected SPDs.

2.0 Installation

⚠WARNING

INSTALLING AN SPD THAT IS IMPROPERLY RATED FOR THE ELECTRICAL SYSTEM VOLTAGE COULD CREATE A POTENTIALLY HAZARDOUS CONDITION, RESULTING IN INJURY OR EQUIPMENT DAMAGE.

Preparation for installation

⚠CAUTION

EATON SPD SERIES PRODUCTS MUST BE INSTALLED OR REPLACED BY A QUALIFIED ELECTRICIAN TO AVOID INJURY OR EQUIPMENT DAMAGE.

Before installing an Eaton SPD Series unit, do the following:

Verify that the area is clear of any dirt, debris or clutter that may hamper the installation process.

- Verify that there is enough space to install the SPD. See Section 2.3, "Installation procedures" for dimensions.
- Confirm that all tools and equipment needed for the installation are available.
- Confirm that the system voltage and wiring configuration is the same as the SPD you are installing. Check the voltage rating label on the side of the SPD.

⚠WARNING

TURN OFF THE POWER SUPPLY BEFORE WORKING IN ANY ELECTRICAL CABINET OR ON ANY CIRCUIT BREAKER PANEL. FAILURE TO DO SO COULD RESULT IN INJURY OR DEATH FROM ELECTRICAL SHOCK.

A POOR GROUND, OR GROUNDING/BONDING VIOLATIONS, COULD PREVENT THE SPD FROM PERFORMING AS SPECIFIED. CHECK THE FACILITY GROUNDING SYSTEM. ALL GROUNDING, BONDING, AND EARTHING MUST MEET THE NEC, CEC AND ANY OTHER NATIONAL, STATE AND LOCAL ELECTRICAL CODES.

DO NOT USE THE SPD TO CARRY OR PASS THROUGH GROUND TO OTHER DEVICES OR LEADS. DAMAGE TO THE EQUIPMENT MAY RESULT.

Installation locations

Eaton's SPD Series can be installed next to, above, or below any existing electrical enclosure.

The ideal mounting location for the Eaton SPD Series is as close as possible to the electrical enclosure. The Eaton SPD Series should be mounted in such a way as to minimize any sharp bends in the wiring conduit.

Installation procedures

1. Before mounting the SPD first determine the ideal location and ensure that the mounting surface is adequate to support the weight of the SPD (See Figures 2, 3, 4, 5, and 6 on pages 4, 5, and 6 for model weights). The SPD should be mounted as close as possible to the electrical enclosure and as close as possible to the wiring connection point within the enclosure. This will ensure a minimum wire length and maximum SPD performance.

2. Layout the four enclosure mounting holes using the enclosure dimensions provided in Figures 2, 3, 4, 5 and 6 on pages 4, 5 and 6. Drill the appropriate holes per the product dimensions.

Note: NEMA 1 enclosures require a #10 fastener and NEMA 4 and 4X enclosures require a 1/4 inch fastener

3. Determine the correct length and install metal conduit onto the SPD. NEMA 1 SPDs have a 3/4 inch trade size chase nipple and NEMA 4 and NEMA 4X SPDs have 3/4 inch trade size hubs. Route all phase, neutral (where applicable), ground and Form C (where applicable) wires through the conduit.

4. Determine the hole location on the receiving electrical enclosure and either remove the knock-out provided or drill the appropriate size hole at this location. Route the SPD wires through the enclosure hole and mount the SPD enclosure.

5. Select the correct wiring diagram for the SPD you are installing. You must refer to this diagram while wiring the SPD. See Figure 9 - Figure 13. SPD Series type 1 and type 2 units do not require over current protection devices, fuses or circuit breakers to operate correctly. All local and national electric codes must be followed during installation and these codes may require protection of the conductors leading to the SPD unit.

6. Determine the wire length required to make the SPD phase connections and cut the wires to the appropriate length. (To maximize SPD performance, wire length should be as short as possible). Connect the phase wires.

Note: For wire lengths longer than 4 inches, phase wires should be twisted once for each 4 inches of wire length to maximize SPD performance.

7. Determine the wire length for the ground and neutral (where applicable) wires and cut these wires as needed. Again, keep these wires as short as possible to maximize SPD performance.

8. Standard, Standard with Surge Counter, and Power Xpert SPD provide a connector for form C relay contacts. This connection can be used for remote monitoring of the SPD. The form C contacts are rated at 150Vac @ 0.46A or 30Vdc @ 1A. Wire the remote monitoring connections per the form C wiring diagram in Figure 8. Follow all NEC, CEC, state and local electrical codes when making these connections.

9. Power Xpert SPD includes an ethernet port located on the side of the enclosure to allow the user to connect the SPD to either a laptop or a network connection using a cat 5e cable (not provided).

Note: To maintain a NEMA 4 enclosure rating when connecting an ethernet cable to the enclosure install a Conec RJ45-IP67 plug kit p/n: 17-10001 to the enclosure as shown in Figures 2 -6..

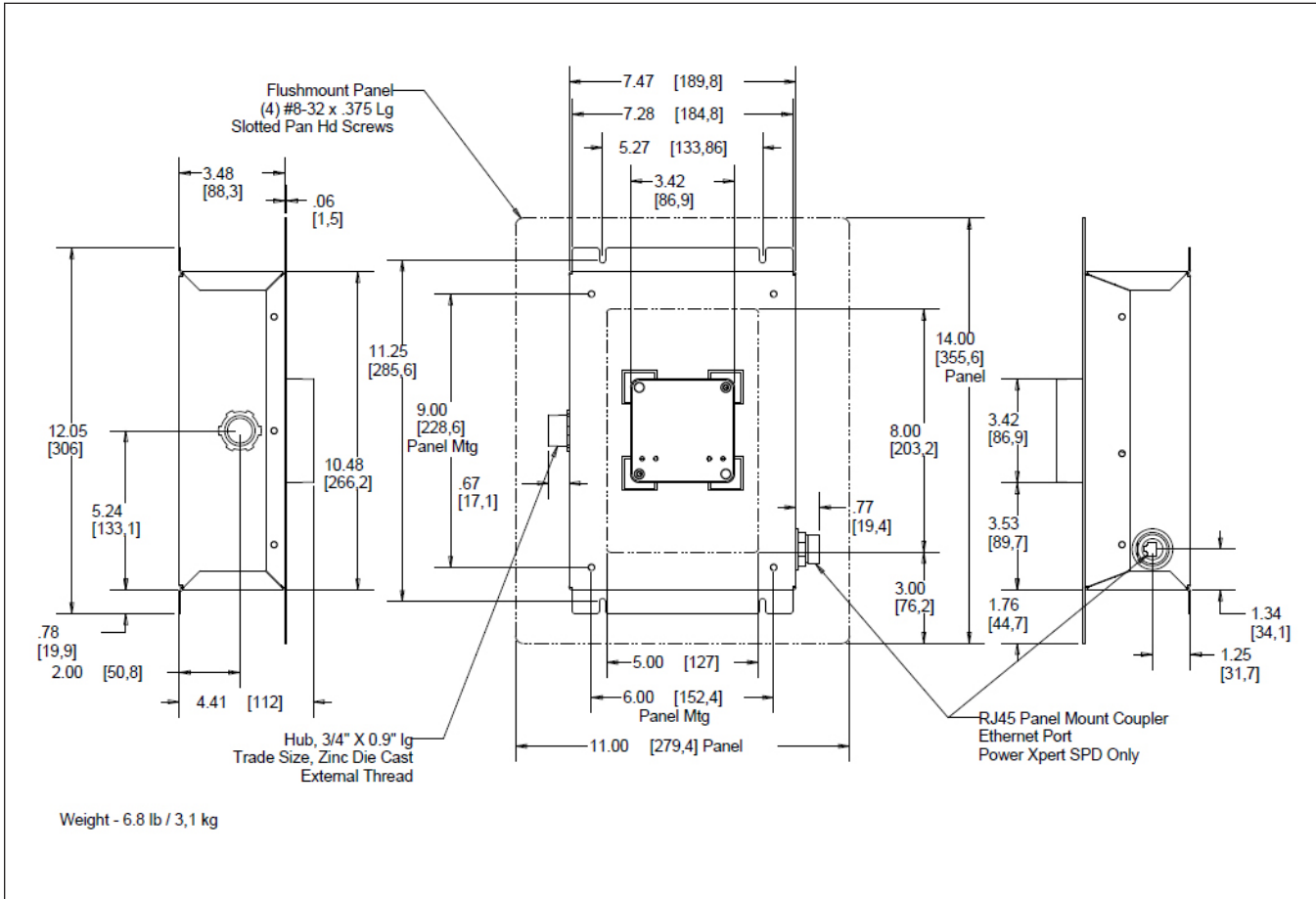

Figure 2. NEMA 1 (with flushmount) (suffix L)

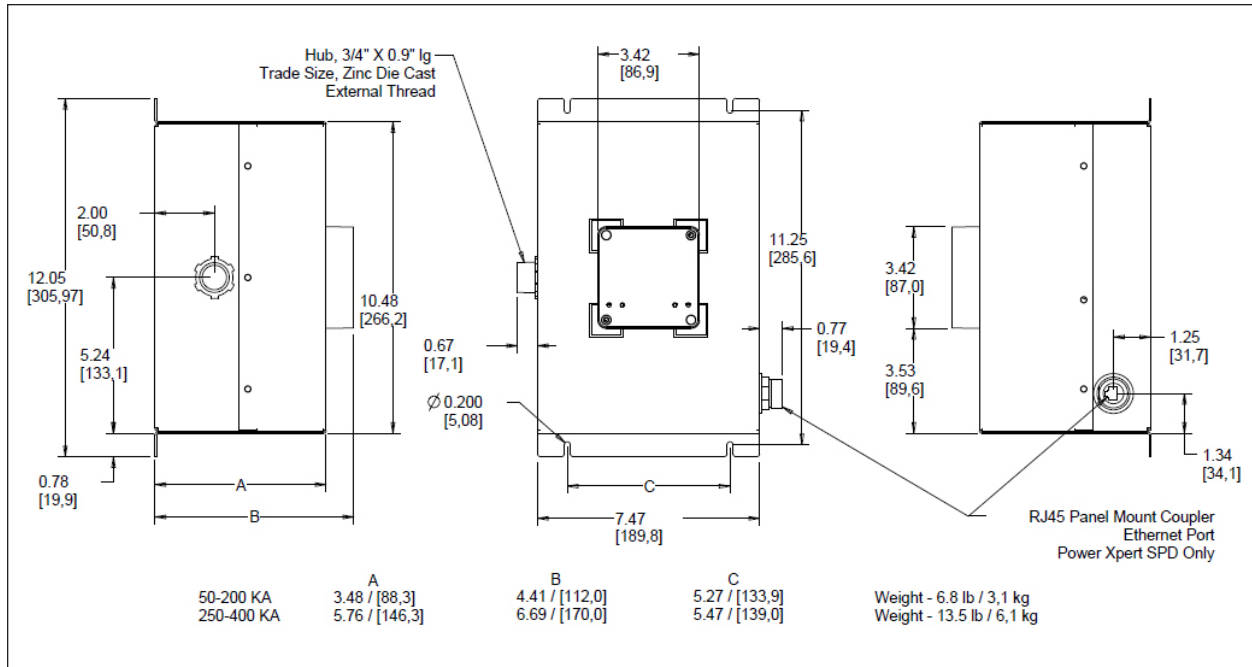

Figure 3. NEMA 1 (suffix K)

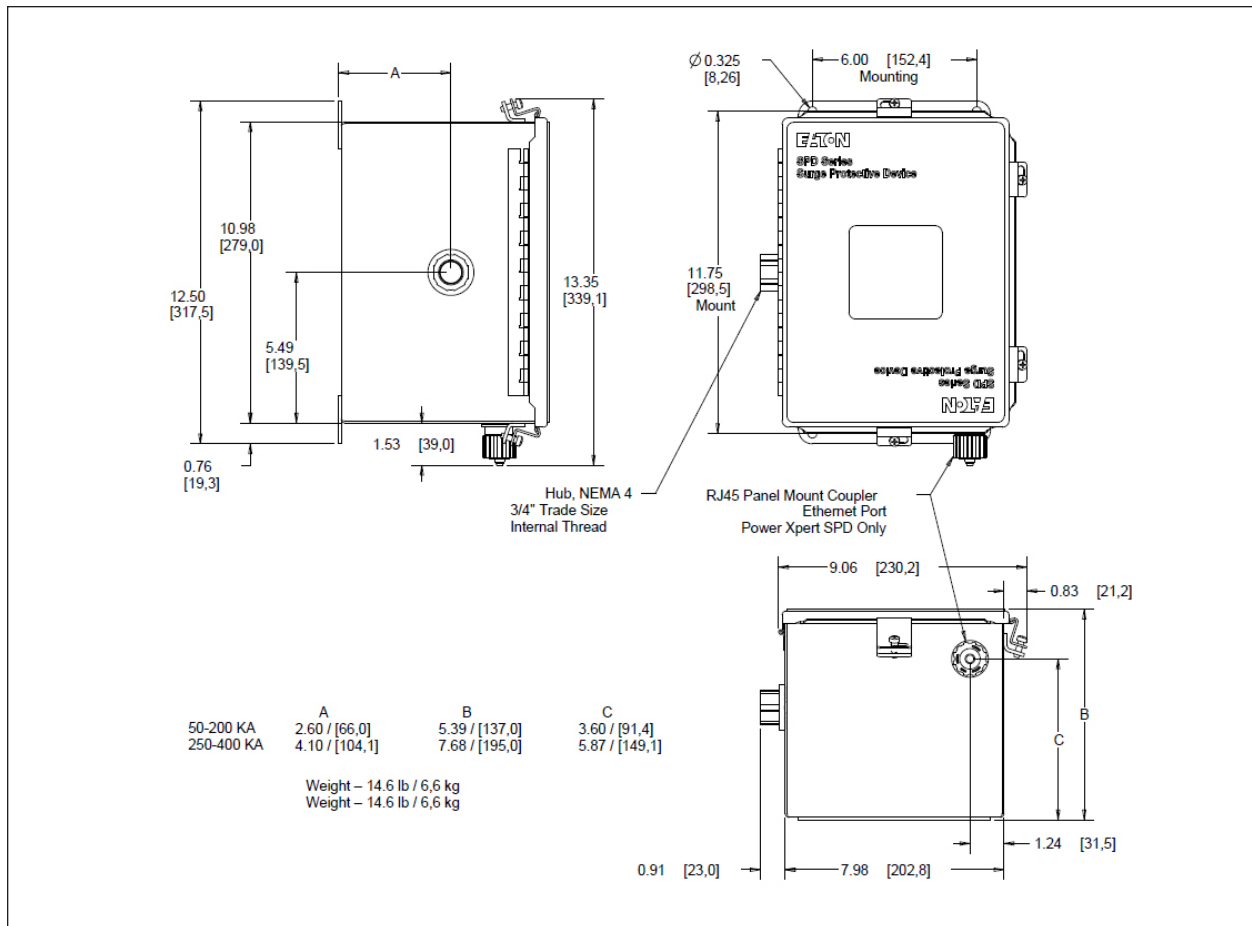

Figure 4. NEMA 4 - 4X (suffix N, P) (NEMA 4X not available with Power Xpert SPD)

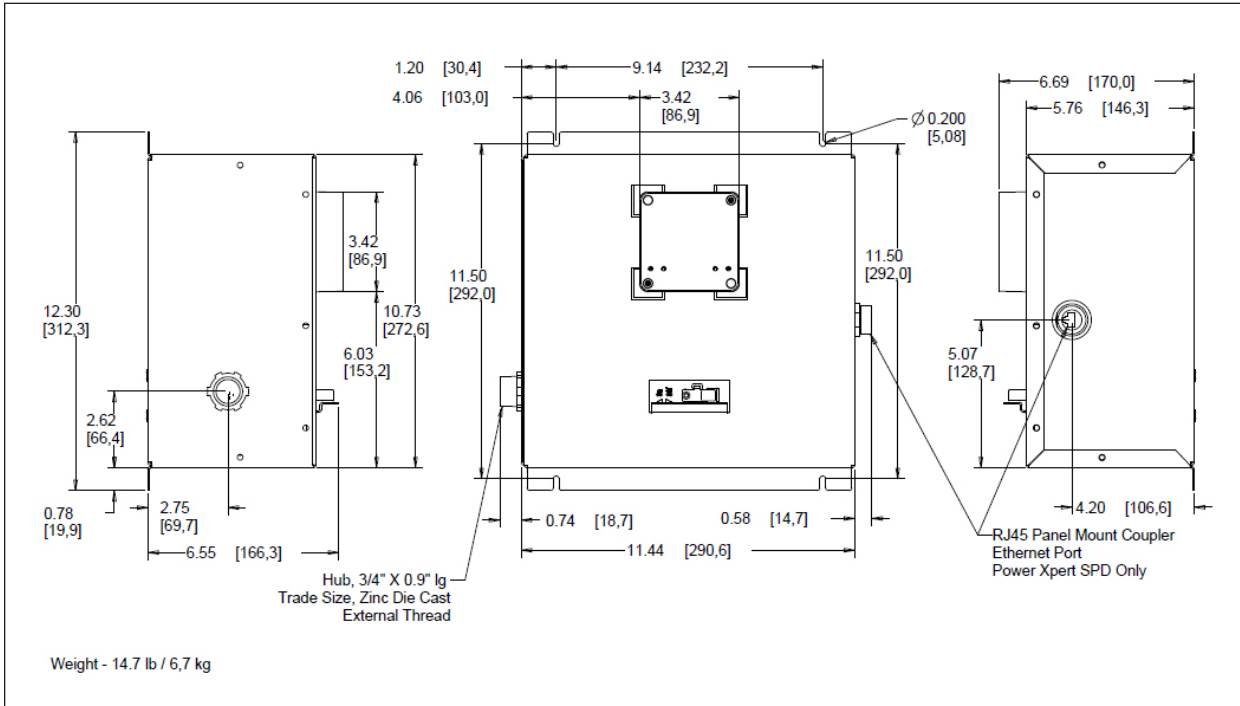

Figure 5. NEMA 1 (with disconnect) (suffix M)

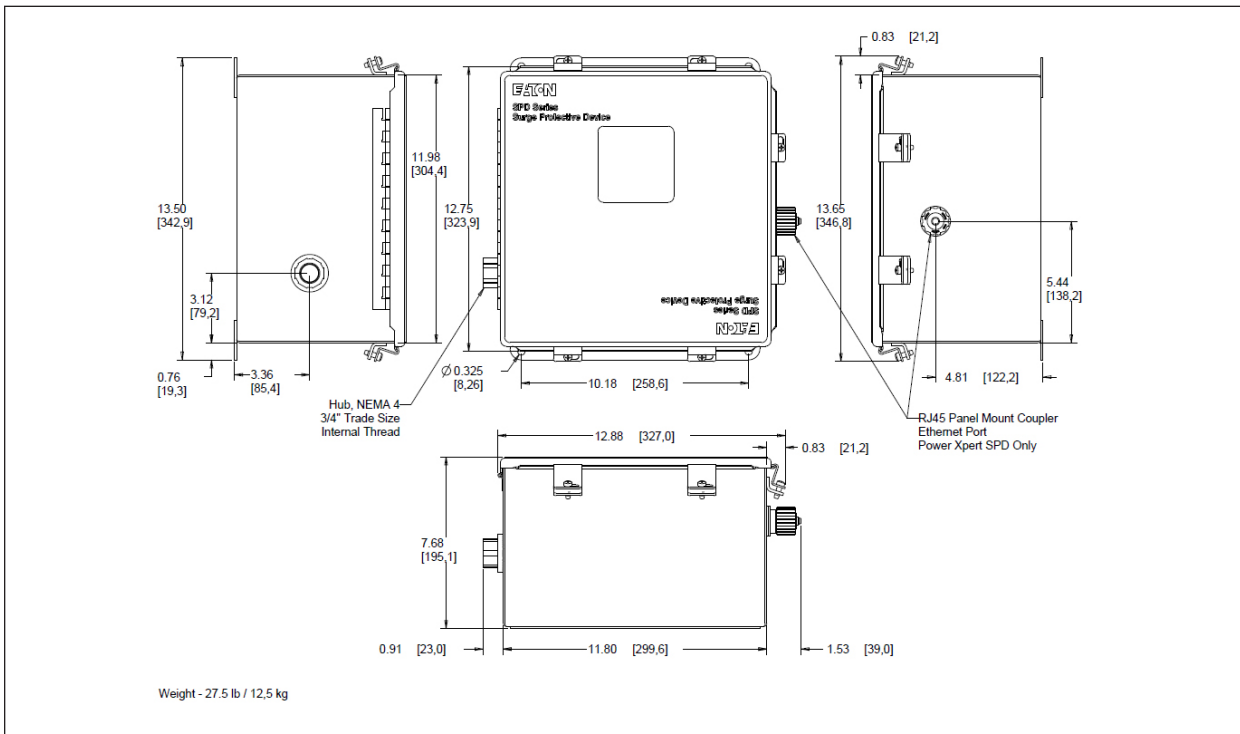

Figure 6. NEMA 4-4X (with disconnect) (suffix O, Q) (NEMA 4X not available with Power Xpert SPD)

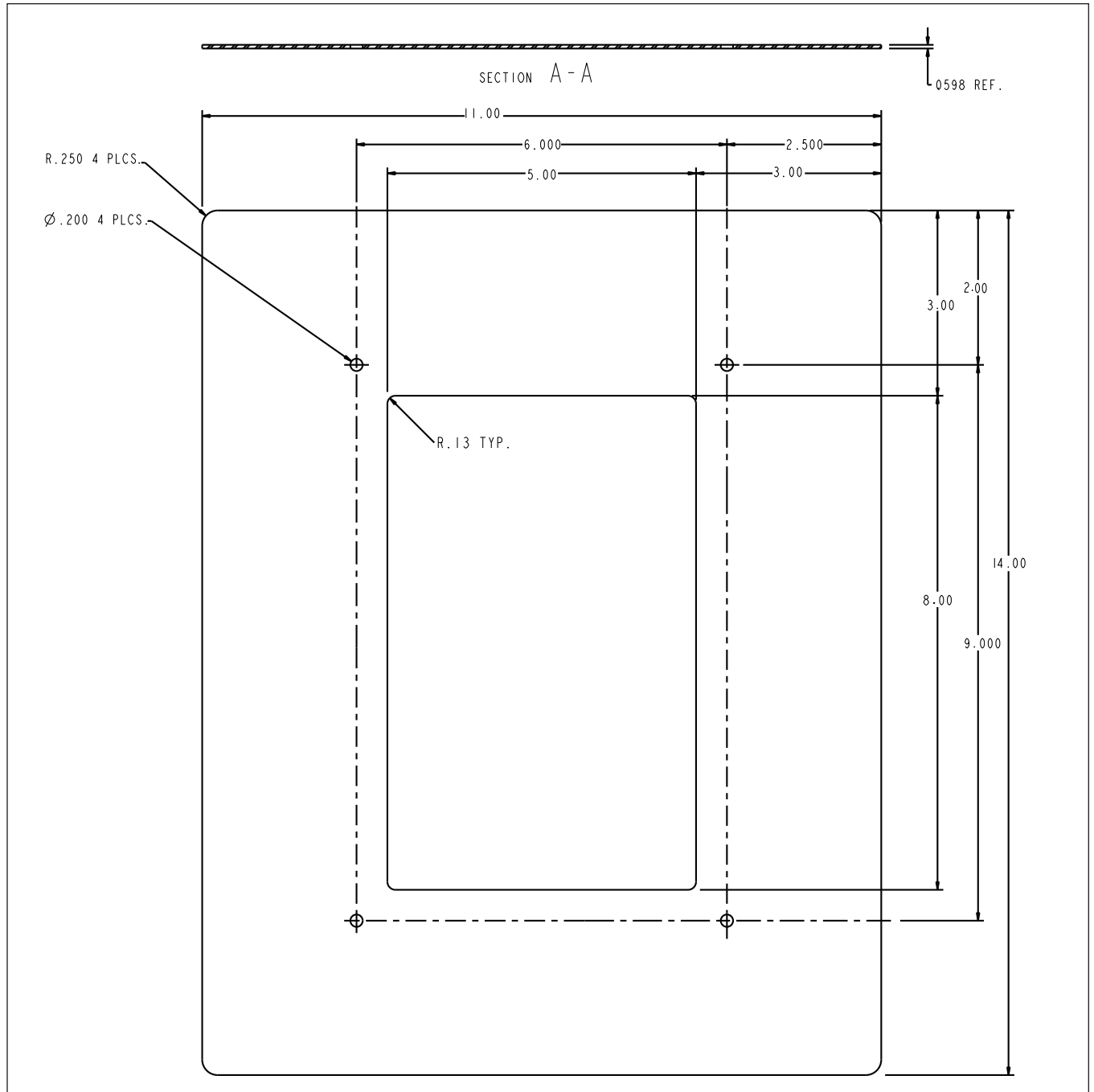

Figure 7. Flush-mount plate for 50-200 kA units in A NEMA 1 rated enclosure Eaton Catalog P/N: SPDGREYFLUSHMTKIT.

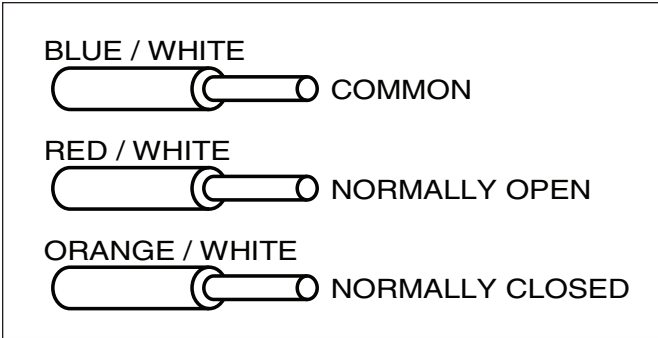

Figure 8. Sidemount form C wires

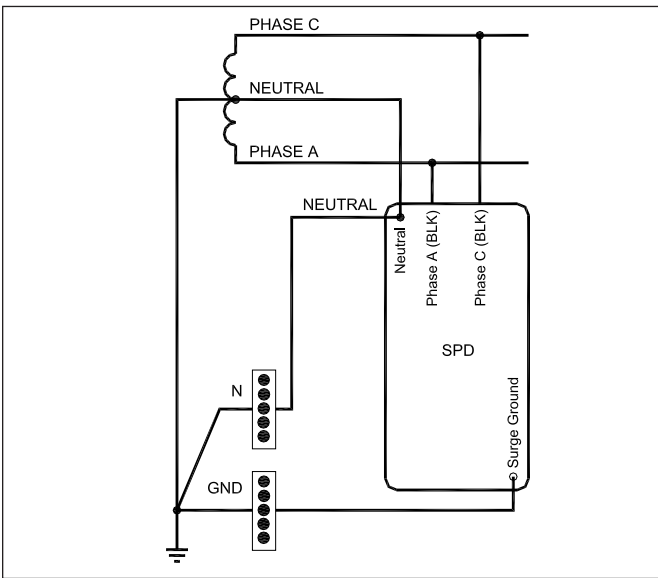

Figure 9. Split phase units

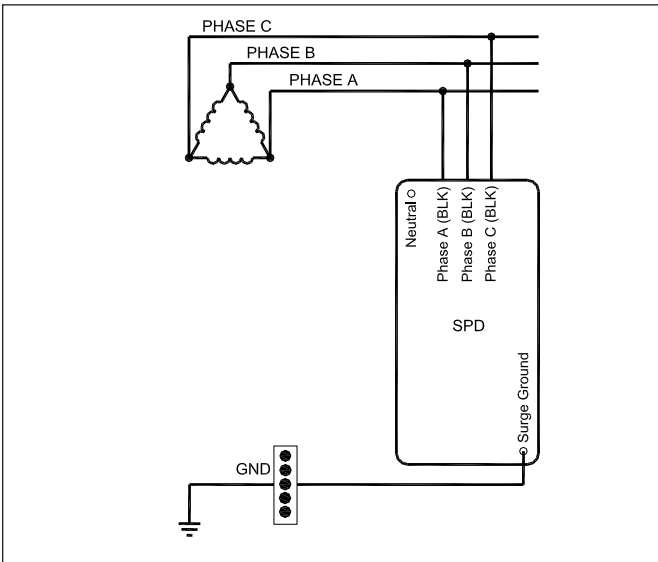

Figure 10. 3-phase delta

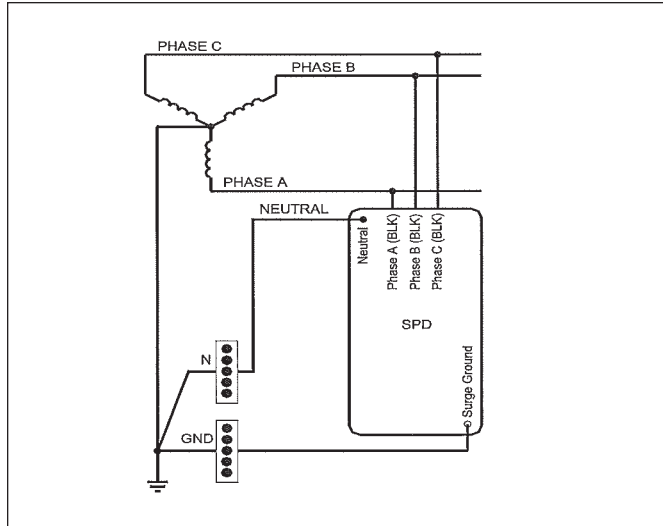

Figure 11. 3-phase wye units

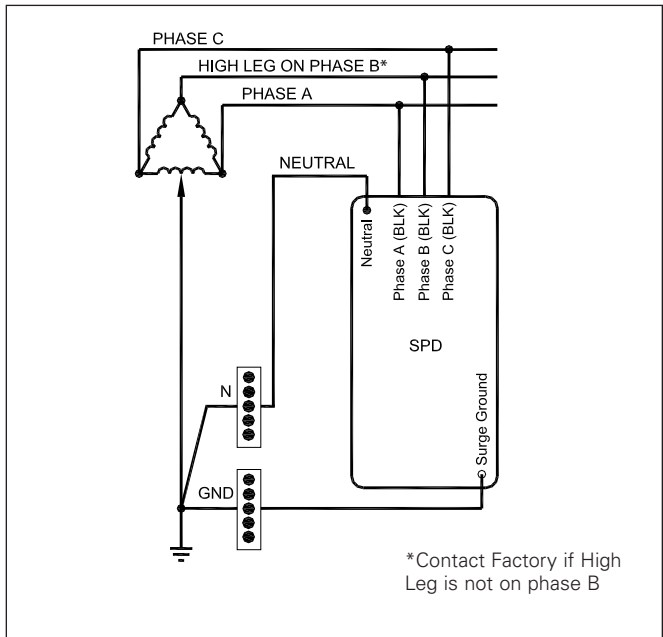

Figure 12. High leg delta units

CAUTION

DAMAGE WILL OCCUR TO THE DEVICE IF THE HIGH LEG IS NOT ON PHASE B.

Note: Please consult the factory for 240 delta high leg applications with high leg on the 'C' phase.

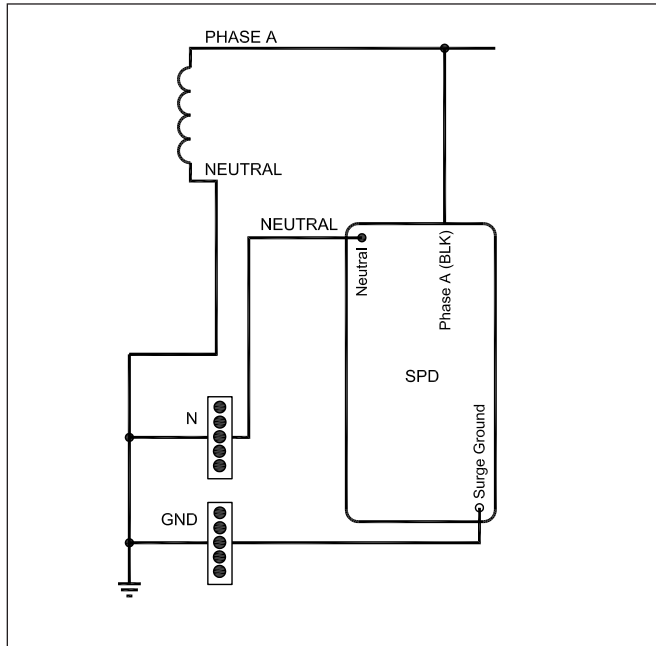

Figure 13. Wiring - single phase units (230 L)

3.0 Operating features

General

The Eaton SPD Series comes in four feature packages: Basic, Standard, Standard with Surge Counter, and Power Xpert SPD. The operating specifics of each feature package are described below.

After system power is applied, the SPD automatically begins protecting downstream electrical equipment from voltage transients.

Three of the four feature packages include a form C relay contact that allows for the remote indication of SPD status.

Displays and indicators

All Eaton SPD Series units (Basic, Standard, Standard with Surge Counter, and Power Xpert SPD) use a display panel to indicate system status. The display panel is slightly different for each feature package.

The Basic, Standard, and Standard with Surge Counter display has green and red light emitting diodes (LEDs) to indicate the status of the protection on each phase. Green indicates the phase is fully protected. Red indicates a loss of protection. Wye, split phase and high-leg delta units have an additional set of green/red LEDs to indicate status of neutral/ground protection.

The Power Xpert SPD has a 20x4 LCD display and up to four multi colored LEDs that indicate the status of protection on each phase and neutral/ground, if equipped. Green indicates the phase is fully protected. Yellow indicates a partial loss of protection, and red indicates a total loss of protection on a particular phase and the SPD should be replaced.

When the LEDs turn red, an audible alarm will also sound on units equipped with an audible alarm.

Specific operating conditions displayed for each Eaton SPD Series feature package are described below.

Basic feature package

The Eaton SPD Basic feature package display is shown in Figure 14



Figure 14. Basic feature package display

The Basic feature package has the following features:

- Green LEDs: Illumination indicates the phase is fully protected, and operating normally, with all protection active and available. Green LEDs also indicate neutral to ground protection on units with a neutral wire. Green LEDs do not indicate on/off status of power.

- Red LEDs: Illumination indicates a loss of protection, and that one or more protective devices are now inactive and unavailable for that phase. Red LEDs also indicate neutral to ground protection on units with a neutral wire. Red LEDs do not indicate on/off status of power.

Standard feature package

The Eaton SPD Series Standard feature package display is shown in Figure 15.



Figure 15. Standard feature package display

The Standard feature package has the following features:

- All features of the Basic feature package.
- One form C relay contact rated at 150Vac @ 0.46A or 30Vdc @1A.
 - Normal operating conditions. N.O. = OPEN. N.C = CLOSED.
 - Loss of protection on any phase or loss of power. N.O. = CLOSED. N.C. = OPEN.
- Audible alarm with alarm silence pushbutton.
- EMI/RFI filtering.

Standard with Surge Counter feature package

The Eaton SPD Series Standard with Surge Counter feature package display is shown in Figure 16.



Figure 16. Standard with Surge Counter feature package display

The Standard with Surge Counter feature package has the following features:

- All features of the Standard feature package.
- LCD screen that displays surge count.
- Reset button to RESET the Surge Counter to zero.

Power Xpert SPD feature package

The Eaton Power Xpert SPD feature package display is shown in Figure 17.



Figure 17. Power Xpert SPD display

The Power Xpert SPD has the following features:

- All features of the Standard with Surge Counter feature package plus advanced monitoring and communication.
- Display upgraded to a 20x4 character liquid crystal display (LCD). LCD technology is readable above -20°C, however surge protection is fully functional to -40°C.
- Power Xpert Gateway 900 (PXG900) with firmware version 4.6.4 and higher are Modbus TCP supported and configurable with the ability to receive email notifications. Modbus TCP/IP must be enabled on the PX-SPD prior to use.
- LCD main menu options include the following:
 - SPD status - surge event logs
 - Event logs – all events, including phase protection percentage, phase loss, alarm status, power on/off and low, med and high level surges
 - Settings - includes device setup, changing the password and the option of giving the device a new name.
 - Identification - information on the device
- One form C relay contact rated at 150Vac at 0.46A, 30Vdc at 1A. Normal operating conditions. N.O. = OPEN. N.C = CLOSED. Loss of protection on any phase or loss of power. N.O. = CLOSED. N.C. = OPEN.
- Audible alarm with push any button to silence.
- EMI/RFI filtering.
- Remote monitoring via web UI, Modbus TCP/IP or BACnet/IP protocols. Modbus, BACnet and HTTP are initially disabled for cybersecurity purposes.
- Phase surge event counters.
- Time/date stamp event logs.
- Green LEDs: Illumination indicates the phase is fully protected (100%), and operating normally, with all protection active and available. Green LEDs also indicate neutral to ground protection on units with a neutral wire. Green LEDs do not indicate on/off status of power.
- Yellow LEDs: Illumination indicates a partial loss of protection (>1% to 99%), and that one or more protective devices are now inactive and unavailable for that phase.
- Red LEDs: Illumination indicates a total loss of protection (0%), and that one or more protective devices are now inactive and unavailable for that phase. Red LEDs do not indicate on/off status of power.

4.0 Power Xpert SPD display menu

The Eaton Power Xpert SPD feature package includes a 20x4 LCD display which on power up displays the device's home screen which includes the following: catalog number, device name (which is editable by the user), time, and firmware version.



Figure 18. Power Xpert SPD home screen

To enter the main menu from the home screen, push the enter key. The following selections will then appear on the screen. The less than symbol "<" represents the cursor location and will appear to the right of the selected menu category. Press the down arrow to scroll down through the selections or press the up arrow to move up. Press the enter button to select a menu item or press the back button to return to the previous menu screen.



Figure 19. Power Xpert SPD main screen

SPD main menu selections

The main menu consists of four menu selections.

1. SPD status

Includes the following sub-menu selections.

Surge events – which contains a subset of menu selections that includes events that occurred on each phase, the level of the surge event (low, med, high) on each phase, the total number of surges on each phase and the total surges and their level (low, med, high)

Protection level – percentage of surge protection remaining in the device per phase.

Alarm status – status of the alarm "Protected" or "Active Alarm Replace SPD"

2. Event log

All events - Up to 40 events which include surges, power up, power loss, protection reduced (%), protection loss, and alarm silence with time and date stamps of when the event occurred are viewable to the user.

Low, med and high surges - Up to the last 20 date stamped events. See Appendix B also.

3. Settings

A valid User password must first be entered and confirmed before a user can access the following selections.

Set date and time – set the current time and date for accurate date and time stamped events. (Automatically synced when connected to a network). Temperature variations and other factors can affect accuracy. Also, if the unit has been without power for an extended period the date and time will have to be re-entered..

Set device name – name the device to distinguish it from other devices on your network. Device name can be up to 20 alpha numeric characters.

Start display test – cycles through the LED states and then turns on and off the LCD pixels and tests the alarm.

Change password – changes the device password. Requires a 6-digit numeric password.

Clear surges & logs – Clears all surge counts and event logs

Sensitivity setting – Increase or decrease the low surge sensitivity. It is not recommended for the user to modify this setting without first contacting Eaton Customer Support at 1-800-809-2772 or email SPD@eaton.com.

Communications – Configure Modbus TCP, ethernet, and IP, subnet mask, and MAC addresses. BACNet must be configured through the web UI. See Appendix F for the Modbus register map. See Appendix H for the BACnet register map.

4. Identification

This section contains information about the device itself. It includes the following:

- Catalog number
- Style number
- Serial number
- Date code
- Firmware version
- PCB serial number
- Device name
- MAC address
- Customer support information

This information is necessary when contacting customer support concerning the device.

5.0 Power Xpert SPD user setup

5.1 General

The Eaton Power Xpert SPD can be monitored through the local display or through a PC with a cat 5e cable and the PC's web browser. Modbus, BACnet and HTTP are initially disabled to provide cybersecurity protection. Modbus can be enabled through the LCD module or the web UI. BACnet and HTTP can only be enabled through the web UI. The PX SPD must be rebooted after enabling Modbus or BACnet communications.

5.2 Setup using only the local display

Once the SPD has been powered up the device's home screen will appear on the local display. See below. The home screen shows the catalog number of the device, the device's name, the time and the firmware revision.



Figure 20. Power Xpert home screen

Setting up the date and time

To set the current date and time, press enter to go to the main menu.



Figure 21. Power Xpert main menu

Now scroll down the menu to settings by pressing the down arrow button. The cursor "<" is located to the right of the menu category selection. Position the cursor to the right of settings< by pressing the down button twice and then press enter.



Figure 22. Move cursor to settings

Next, enter a 6-digit password by pressing the up button to the desired first number, if you go past the number press the down button. Then press enter to go to the next digit. Repeat the process until all 6 digits have been entered. After all 6 digits have been entered press enter to continue.



Figure 23. Password screen

Next, select the date and time category by pressing enter.



Figure 24. Select date and time

Next press the enter button to edit the date and time or the back button to exit and return to the previous screen.



Figure 25. Setting date and time

Press up to enter the month, then press enter to move to the date selection. Press up to enter the date, then press enter. Next press up to scroll to the current year. Press enter to move to hours and repeat the process for minutes and seconds. Finally press enter to save the settings and then return to the previous screen. (Time will initially be displayed in UTC time on the web UI. This can be changed through the web UI.

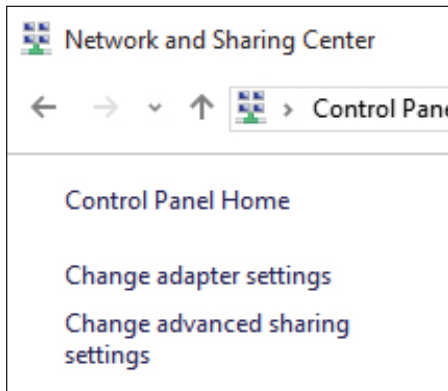

Figure 26. Saving the date and time

5.2.1 Configuration of the user's laptop to communicate to PX-SPD

Follow these steps to enter the IP and Subnet Address on the user's laptop or PC.

1. In Windows applications, navigate to Network and Sharing Center.



2. Click on Change adapter settings

3. Left click on Ethernet and then right click to open the window shown below. Then click on Properties.

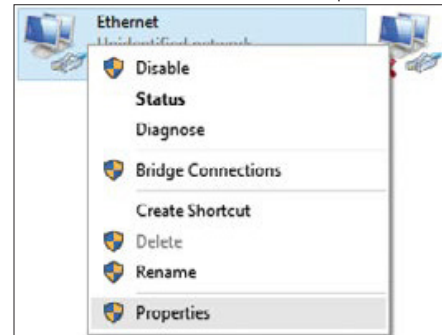

4. Click on Internet Protocol Version 4 (TCP/IPv4).
5. Click on Properties.

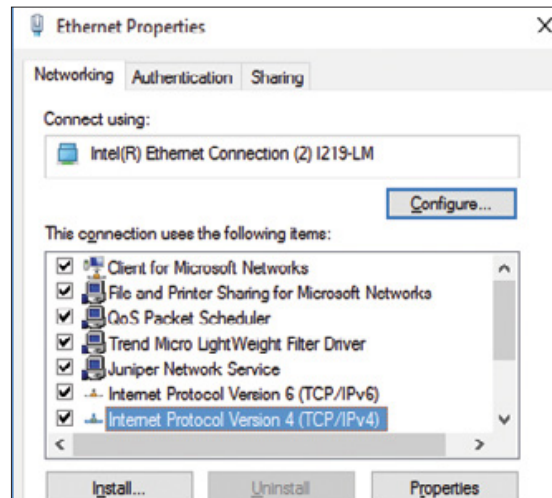

6. On the General tab, select Use the following IP address:
 - a. Enter 192.168.1.10 for the IP address
 - b. Enter 255.255.255.0 for the Subnet mask
 - c. enter 192.168.1.1 for Default gateway

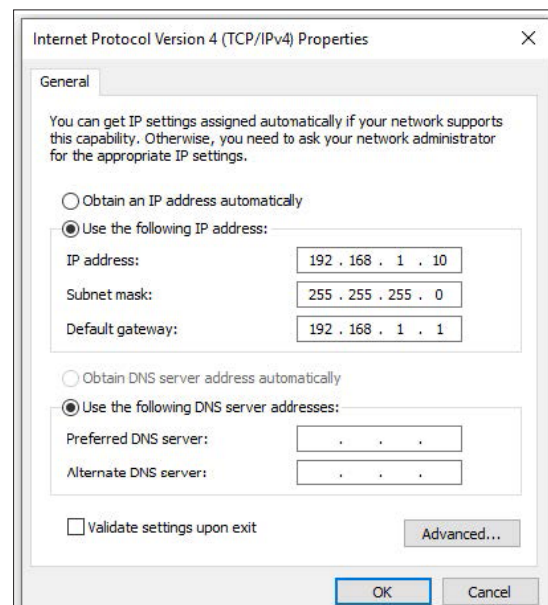

7. Click on OK button and then exit out of all these open windows.

5.3 Power Xpert SPD Network Connection

Plug one end of a Cat 5e ethernet cable into the SPD and the other into a laptop PC which is connected to a network. The device comes from the factory with the default IP address listed below but can also be setup for dynamic IP (DHCP) or a user defined static IP address.

Default IP address is: 192.168.1.254

Default user: admin

Default password: Admin*1

Open Google Chrome, or Internet Explorer 11.x or higher and enter the fixed IP address 192.168.1.254 and then hit the enter key.

This window will open.

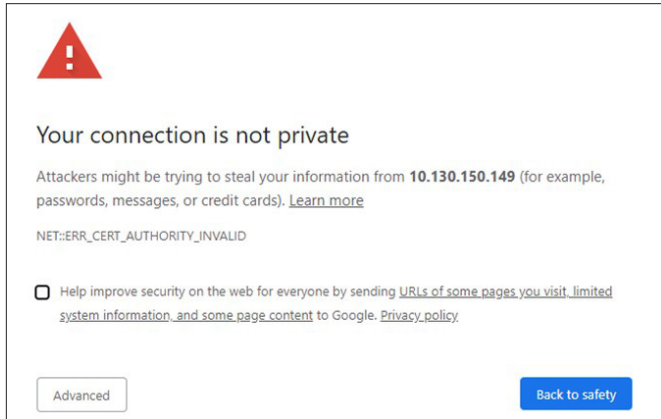

Click on Advanced.

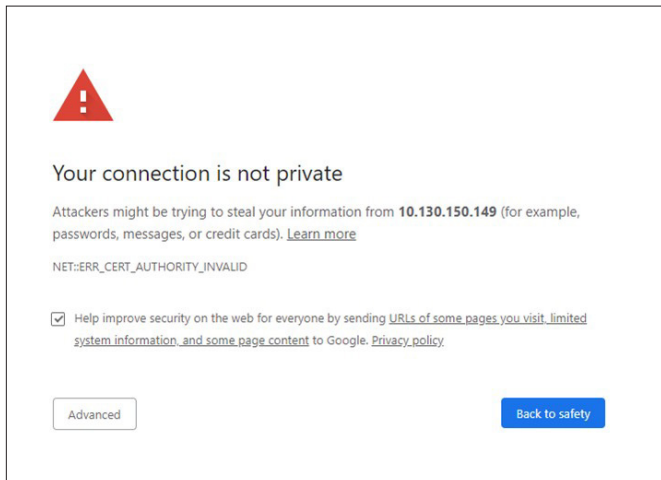

Click on "Proceed to..." near the bottom of the window.

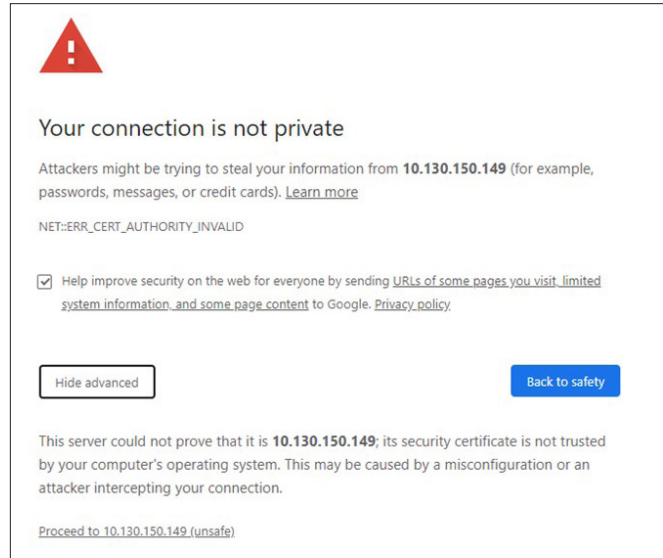

The login screen shown in Figure 27 will open. Enter the default user name and password shown above and press the enter key.

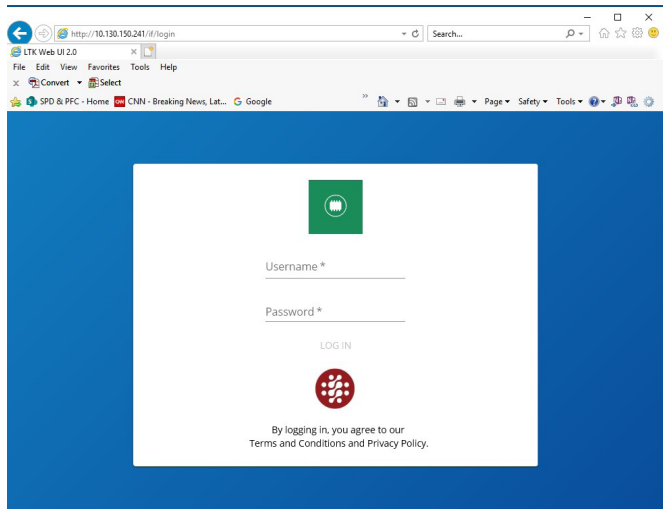

Figure 27. Power Xpert login screen

The change password window will open. Enter the default password and then enter a new 6 digit alpha-numeric password and then click OK. Save password in a secure location to access the Web UI. If lost, contact Eaton's Application Engineers, at 1-800-809-2772, or email SPD@eaton.com.

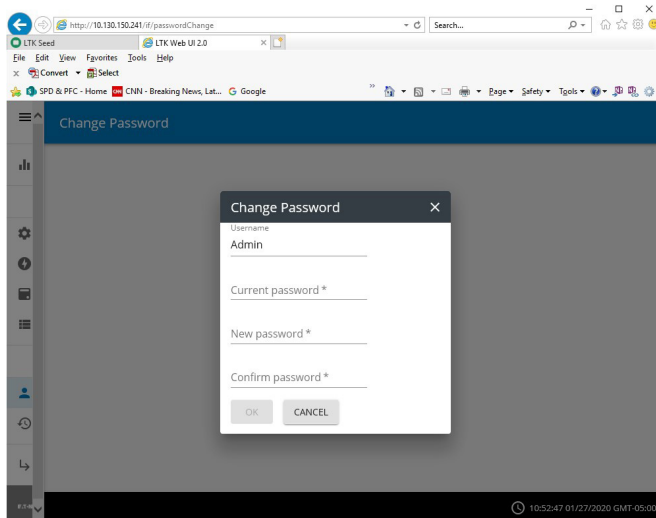

Figure 28. Password screen

Then it will return to the overview screen.

Password security: The Power Xpert SPD is shipped with factory default user authentication credentials to allow for initial installation and configuration. However, factory default authentication credentials are often well known, easily discoverable and present a significant security risk; therefore, the admin user name and admin password should be changed at installation to increase cybersecurity protection.

1. Limit access to the PX-SPD to reduce cybersecurity risk.
2. The maximum number of users that can be setup is six.
3. User names should be 5 characters in length or more.
4. Password expiration is configurable, the default is set to 90 days.
5. Up to three users can access the PX-SPD simultaneously.

Admin users assign a role to new users from one of four possible roles under the User Management tab through the web UI.

Table 2. User role privileges

Role	Description	IP Addr	Modbus TO	User/Pass	Factory Reset	Reboot
Admin	All privileges	R/W	R/W	R/W	R/W	R/W
Engineer	Product configuration	R/W	R/W			
Operator	Read only	R	R			
Viewer	Read only	R	R			

R – Read access
W - Write access
IP Addr – IP Address configuration
Modbus TO – Modbus timeout value
User/Pass – Username and password setup

PX-SPD enforces complex passwords and session time-out through User Management tab in the web UI.

There are 4 levels of Password Complexity, defined as follows:

- Password complexity level – 0
 - It should be at least 6 characters long
 - It should not match with user name, full name or existing password
- Password complexity level – 1
 - It should be at least 8 characters long
 - It should not match with user name, full name or existing password
 - It should contain at least 1 alphabetic and 1 numeric character
- Password complexity level – 2
 - It should be at least 12 characters long
 - It should not match with user name, full name or existing password
 - It should contain at least 1 alphabetic, 1 numeric character, 1 special character, and 1 upper case alphabetic character
- Password complexity level – 3
 - It should be at least 16 characters long
 - It should not match with user name, full name or existing password
 - It should contain at least 2 alphabetic characters, 1 numeric character, 2 special characters, and 1 upper case alphabetic character.

5.3.1 Establishing a secure connection

After initial login, the user will notice that the address bar on the web browser shows that the connection is Not secure, see example below.



To obtain a secure connection, click on the network tab, then click on download certificate.

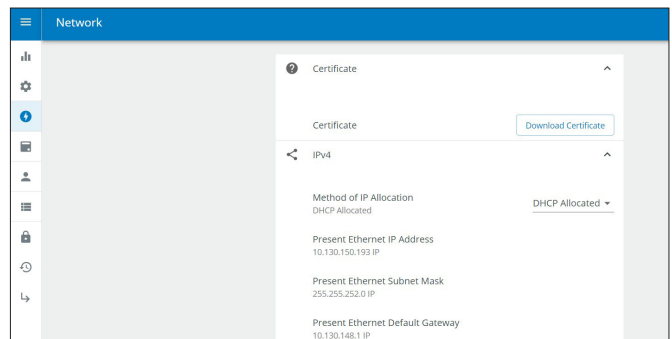

Figure 29. Download certificate

Download the certificate file, cert.cer.

The install certificate window will then open and then click on install certificate button.

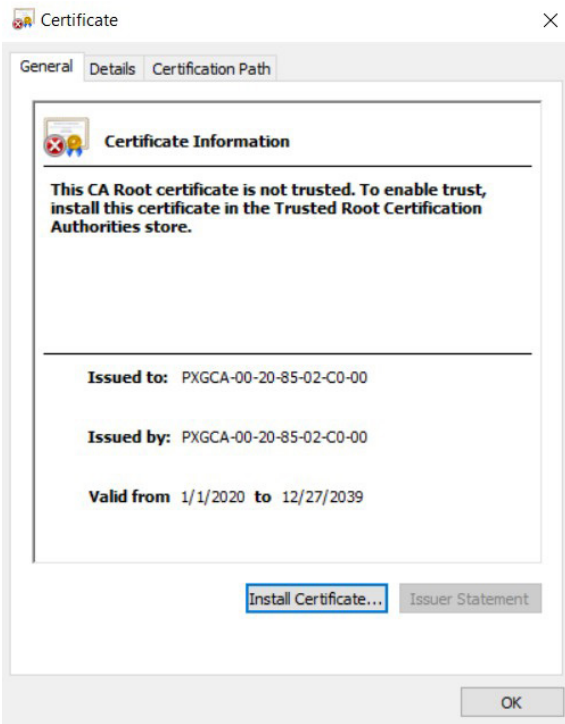

Figure 30. Install certificate

Then the Certificate Import Wizard will open. Select current user and then click next.

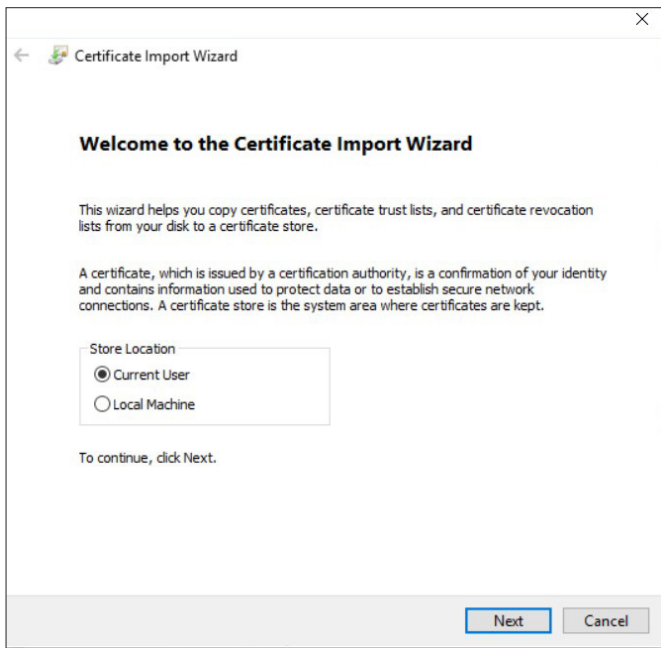

Figure 31. Certificate Import Wizard

In the next window click on 'Place all certificates in the following store'. Then click the browse button and then the select certificate store window will open. Next select 'Trusted Root Certification Authorities' from the menu and then click OK. Then select next.

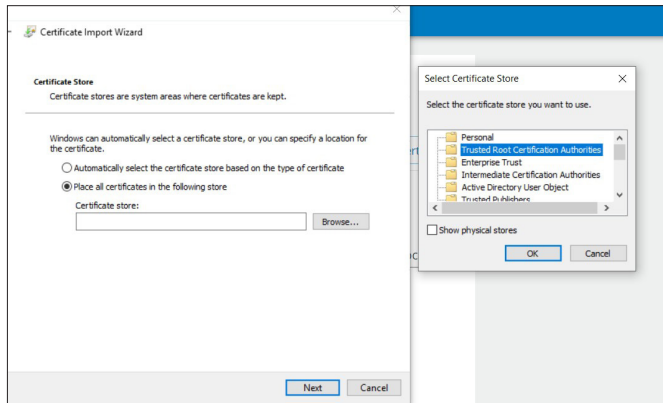

Figure 32. Certificate storage location

Then select finish in the window.

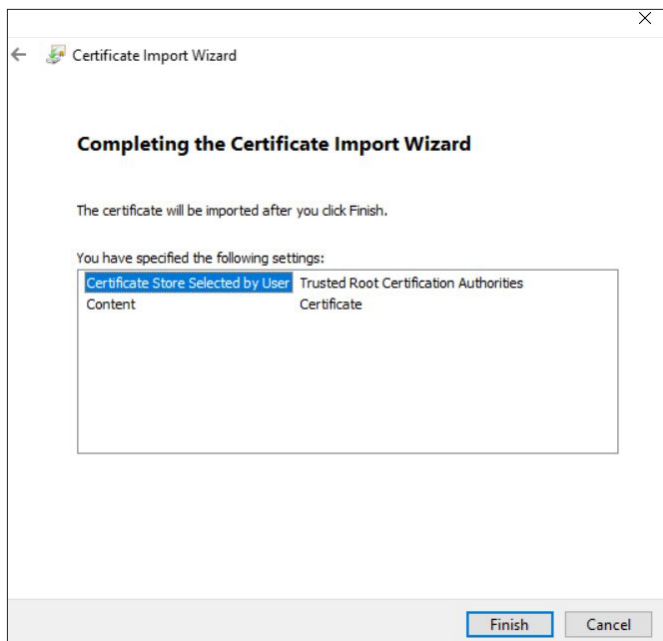

Figure 33. Certificate download finish

Then select yes when the security warning window pops up.

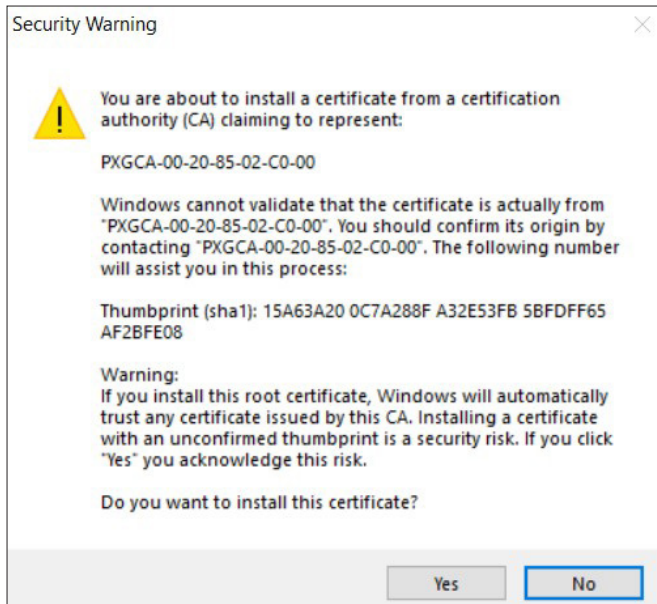

Figure 34. Security warning window

If the import is successful you will receive a pop up window notification as shown below.

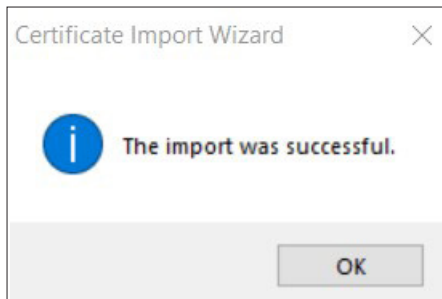

Figure 35. Import successful

Logout of the device, close the browser, re-open the browser and then re-enter the device using secure login beginning with https:// followed by the device's IP address. Once logged in, the address on the toolbar should show the locked padlock symbol similar to the one shown below.



Figure 36. Successful secure login

5.3.2 Upgrading firmware

To update the firmware in the Power Xpert SPD, go to the Eaton website at www.eaton.com/PX-SPD and download the latest version firmware to a laptop or PC.

Connect the laptop to the Power Xpert SPD via an ethernet cable and login to the SPD. Once logged in, scroll to the toolbar on the left and select firmware from the menu.

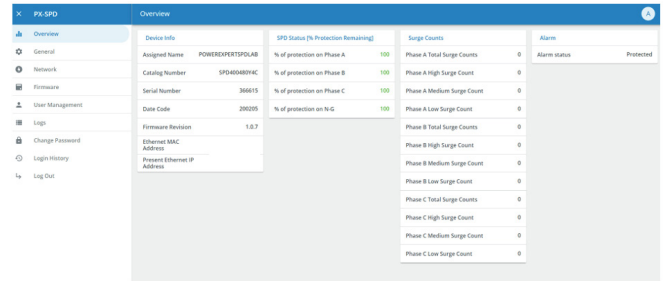

Figure 37. Select firmware tab

The window below opens and then select "OPEN CODEPACK"

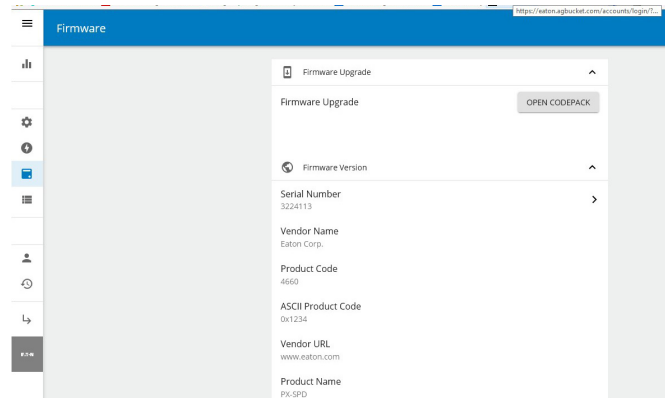

Figure 38. Select open codepack

A window will open to allow the user to browse their hard drive to the place where they saved the downloaded firmware. Select the *.xml file and click open. The End-User License Agreement window will appear. Check the "I agree to the terms of the License Agreement" and then click accept. The firmware update window will open and then click "Select Processor". The firmware/code pack evaluation window will open and then click on the box to the left of PX-SPD_MAIN_PROCESSOR and then click OK. A status window will open and show the status of the download.

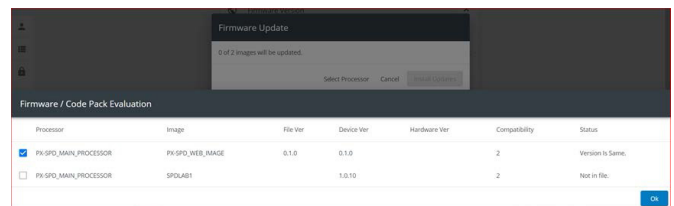

Figure 39. Select PX-SPD_Main_Processor

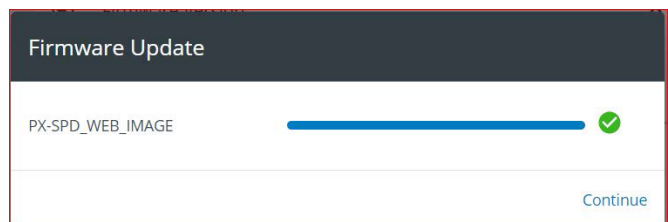

Figure 40. Firmware Update complete

Once the download has been completed the device will return to the login screen.

Login to the device and click on the General tab and verify the SNTP server 1 has a green circle around it, as shown below. This verifies the device has synced with the network and will provide accurate time stamped events.

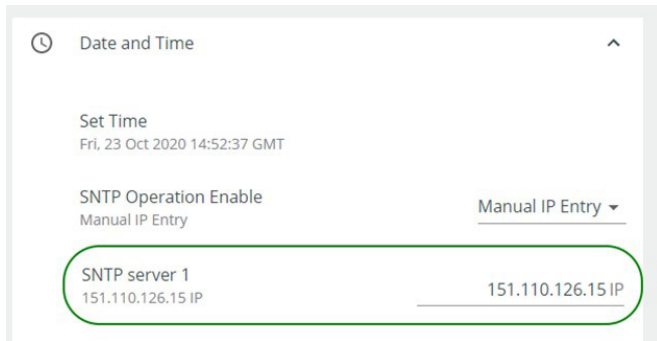

Figure 41. SNTP sync confirmed when circled in green.

5.3.3 Viewing surge logs

To view surge logs hover over the toolbar and then click on logs. (Modbus must be enabled to view surge and general logs.)

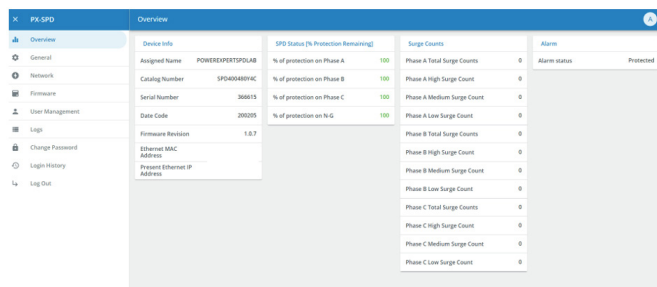

Figure 42. Log screen

Next click on list of logs in the upper left corner of the window.

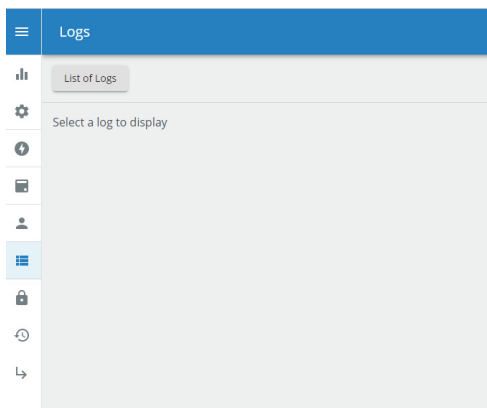

Figure 43. Select list of logs

A dropdown will open displaying the options available to the user. Select the log of interest.

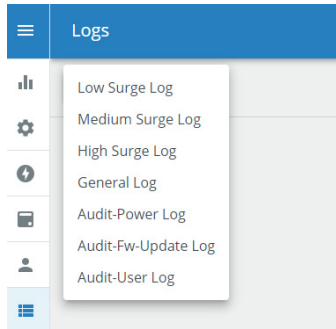

Figure 44. Logs that are available to view

Low, Medium, and High Surge Logs display specific phase surges that occurred in a particular surge category. General Log displays phase protection reduction percentage, phase protection loss, alarm silenced, power on/off. Audit-Power Log displays when the device restarted after a power loss. Audit-Fw-Update Log displays code update history. Audit-User Log displays when Users logged in and out of the device. Once in the log, a list of logging events and their time stamps are displayed. The user has the option of scrolling down through the list or exporting the logs to a *.csv file. In addition, the user can clear logs in that particular log if they choose to do so.

General settings

Under the general setting the user has the ability to set the date and time, time zone, select from four different date formats, reset the device and modify web session settings.

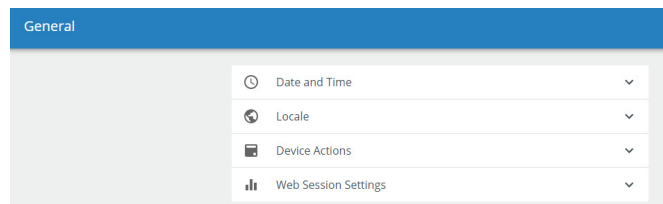

Figure 45. General settings

Syncing the internal clock.

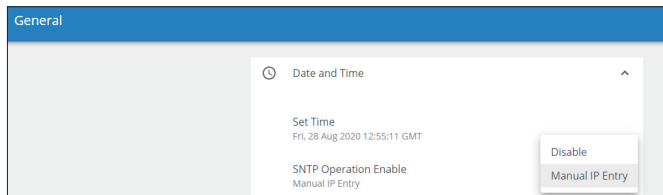

Figure 46. Sync the internal clock

Select the appropriate time zone from the dropdown list to the right of Timezone. GMT-05:00 represents Eastern Standard Time, GMT-06:00 represents Central Time, etc. Date format, with four different date formats to choose from, and the time format.

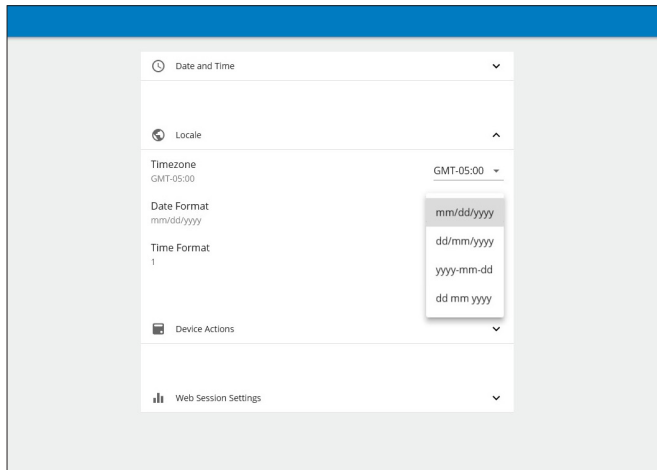

Figure 47. Select time format

Device Actions has two options for the user. Reboot or Reset Device. Reboot is a soft reset, the micro controller will power down and power up. Reset is a hard reset which will reset the device to factory defaults. Either action can only be conducted by an Admin user.

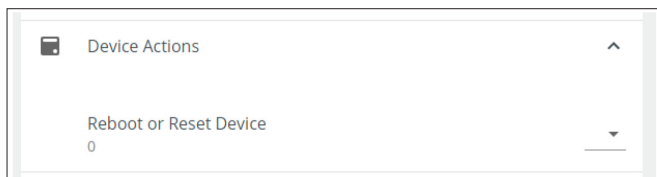

Figure 48. Device actions

The user will be prompted before either of these actions. Click the 'X' in the top right of the window to cancel this action.

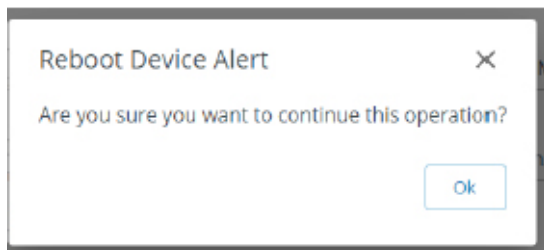

Figure 49. Reboot device alert

The Admin user can modify timeouts, number of concurrent sessions and the number of failed login attempts.

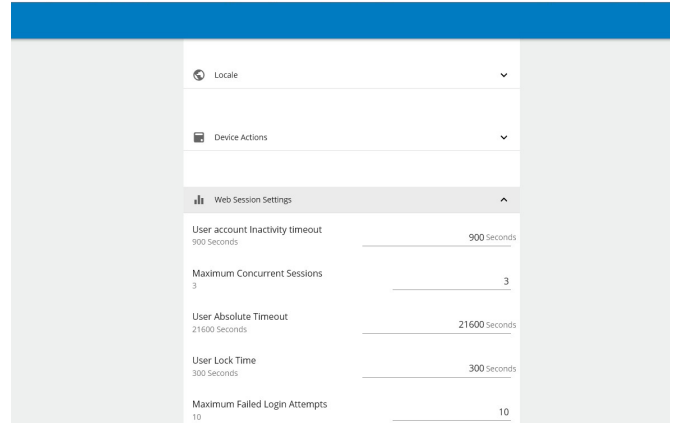

Figure 50. Modifying timeouts

In the network window the following options are listed.

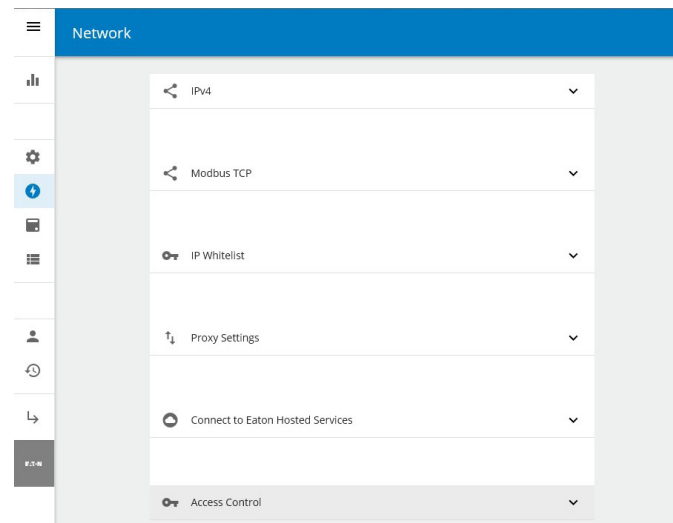

Figure 51. Network tab options

The user can select the IP allocation method between three options and the IP address is also displayed here. The IP allocation method change does not take effect until the unit has been rebooted. The reboot command is available under General tab, Device Actions. (Do not select the Factory Reset command or the device will return to the factory default values with a static IP address.)

IP Allocation Methods available.

- Statically Hardcoded (192.168.1.254) Factory default
- DHCP Allocated (Network assigned)
- Taken from NV stored IP address

Note: The User must reboot the device after performing any of these changes.

Communication setting changes require a reboot of the micro controller to enable it.

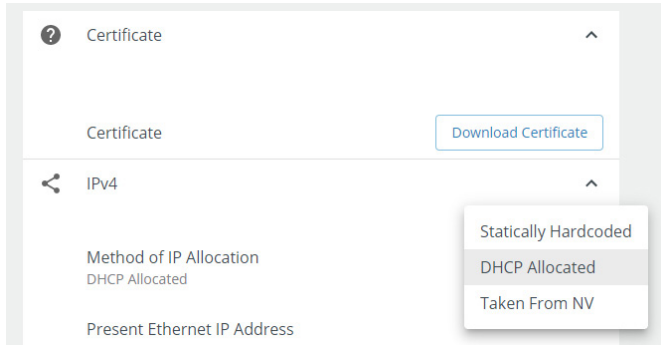

Figure 52. Method of IP allocation

IP Configuration changes require a reboot of the device

To initiate a soft reset from the WebUI, go to the general tab and click on the down arrow across from reboot or reset device as shown below.

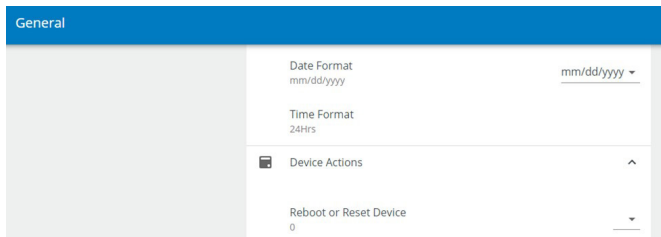

Figure 53. Select on down arrow

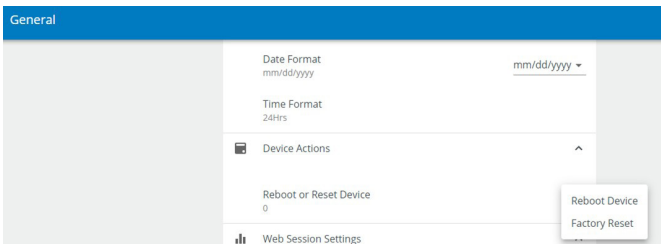

Figure 54. Click on reboot device

Click OK to verify that you want to continue with this operation. The LEDs on the display will turn off, then back on again to indicate that this command has been implemented.

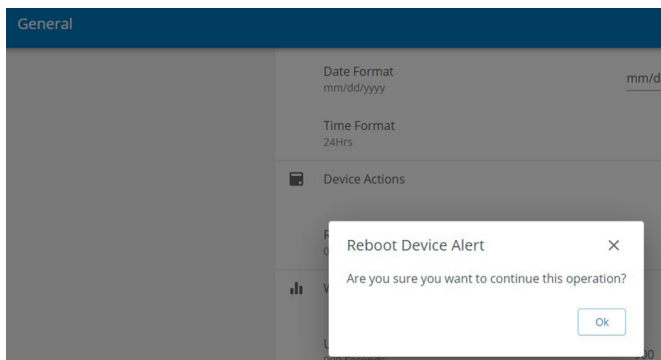

Figure 55. Confirm reboot

A pop up window opens to confirm the reboot.

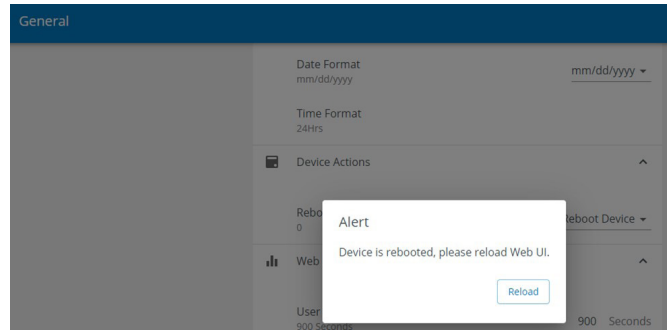

Figure 56. Click on reload

5.3.4 Modbus and BACnet access

The PX-SPD supports Modbus TCP/IP and BACnet/IP using the ethernet port, both are initially disabled. Using Modbus commands, the PX-SPD can be used to read real time parameters, events and logs from the connected PX-SPD. You will need a Modbus TCP capable application such as ModScan which act as the Modbus primary and the SPD is the Modbus secondary. Refer to Appendix F Modbus register map for details on available registers and their properties. Refer to Appendix H for the BACnet register map.

5.3.5 Sensitivity setting

Attention: Eaton does not recommend the customer modify the sensitivity setting without first contacting Eaton Customer Support at 1 800 809-2772 or email SPD@eaton.com. Increasing the sensitivity will reduce the number of low level transient counts.

5.3.6 How to reset the PX-SPD password

To reset the Power Xpert SPD password through the local display, the user must first access the concealed menu. To gain access to the concealed menu return to the home screen, then press the following buttons in order within 5 seconds: up, up, down, down, back, back, enter, enter. This will take you to the local display concealed menu. Follow the screen prompts to reset the passwords. When this password reset command is activated the local display and Web UI passwords are reset to their default values. The Power Xpert SPD Local Display prompts the user for a 6 digit numeric password to be entered before being able to enter the settings menu. The Web UI User name and password returns to default:

User name: admin
 Password: Admin*1

5.3.7 End of life disposal

Before disposing of this device go to Device Actions and select Reset Device to clear logs of any data.

6.0 SPD display rotation

The SPD display can be rotated on the SPD enclosure, up to 360 degrees. This allows you to position the display for the best visibility regardless of the position in which the SPD is installed.

Rotations are at 90, 180, and 270 degrees. Reposition the SPD display as follows:

1. Remove power from the unit.
2. Remove the two Phillips head screws that hold the display.
3. Rotate the display to the desired position. Be careful not to overstress the display ribbon cable.
4. Place the display back onto the SPD enclosure. Again, be careful not to overstress or crimp the ribbon cable.
5. Replace the two Phillips head screws. Tighten screws to 1.35 N·m (12 in-lbs).
6. Restore power to the unit.

7.0 IEC approved models

Eaton's one-port low-voltage surge protective device delta models SPD120480D3M, SPD160480D3M and SPD200480D3M meet the requirements of IEC 61643-11 / EN 61643-11, Part 11: Test Class II, and are intended to be installed in applications with a degree of protection rated IP 20.

The delta models are intended for use with a 3 phase TN-S system with PE and neutral distribution, 5 conductor with a minimum 10 AWG or 6 mm². The delta models are also intended for use with a 3 phase TN-C system with PEN distribution, 4 conductor with a minimum 10 AWG or 6 mm². Screws used for connection to ground shall be #10-32 x 3/8" and shall not be zinc or aluminum. This product is not serviceable and contains no replacement parts.

Additional product information and ratings for IEC applications:

- The SPD contains internal disconnects with a short circuit current rating I_{SCCR} of 200kA.
- Residual current IPE for this product is 5 mA.
- Operating temperature is normal -5°C to 40°C (23°F to 104°F).
- Humidity range is 5% through 95% non-condensing.
- The SPD may be mounted directly to earthed conductive surface, installed as per this manual.
- Temporary overvoltage rating $U_T = 402.6V$.
- Withstand or safe failure mode, $t_T = 120$ minutes, $U_T = 526V$.
- Modes of protection as marked on a delta SPD = L - L, L - G(PE).

Table 3. Viewable events

Event type	Web UI viewable logs							LCD viewable logs			
	General log last 500 events	Low surge log last 2000 events	Medium surge log last 1500 events	High level surge log last 1000 events	Audit power log	Audit fw update log	Audit user log	All events last 40 events	Low level surges last 20 events	Medium level surges last 20 events	High level surges last 20 events
Phase A protection reduced to %	X							X			
Phase B protection reduced to %	X							X			
Phase C protection reduced to %	X							X			
N-G protection reduced to %	X							X			
Phase A protection loss	X							X			
Phase B protection loss	X							X			
Phase C protection loss	X							X			
N-G protection loss	X							X			
Audible alarm silenced	X							X			
Power off/ power loss	X							X			
Power on/ power restored	X							X			
Phase A low, medium or high surge		X	X	X				X	X	X	X
Phase B low, medium or high surge		X	X	X				X	X	X	X
Phase C low, medium or high surge		X	X	X				X	X	X	X
Device restart					X						
Firmware update time stamp						X					
User login & logout							X				

8.0 Troubleshooting

Troubleshooting feature packages 1, 2, and 3

Many SPD failures result from improper installation. Once the SPD is installed properly, it is a highly reliable unit.

If the SPD does not function properly, first confirm that it is installed properly. See Section 2, "Installation."

If the SPD malfunctions after it has been operating routinely, refer to Table 4, Troubleshooting chart. This troubleshooting chart identifies possible causes and solutions to the malfunction. Further assistance may be obtained by calling Eaton's Applications Engineers, at 1-800-809-2772 or email SPD@eaton.com, including being directed to the warranty process if applicable.

Table 4. Troubleshooting chart

Condition	Probable cause	Solution
Green LEDs ON (1 per phase) and one green LED ON for neu/gnd protection	Normal operation	N/A.
Audible alarm OFF, form C (N.C.) contact in the CLOSED state	Normal operation	N/A.
Phase green LED is OFF, same phase red LED is ON, audible alarm is ON.	Phase protection compromised or lost	Replace SPD
	Extended temporary overvoltage (TOV)	Check electrical system for TOV sources, correct, replace SPD.
	Significant surge event	Replace SPD.
Neu/gnd green LED is OFF, neu/gnd red LED is ON, audible alarm is ON (for models with neutral connections) .	Neu/gnd protection is compromised or lost	Replace SPD.
	Significant surge event	Replace SPD.
All phase green LEDs OFF, all phase red LEDs ON, audible alarm is ON.	All phase protection is compromised or lost .	Replace SPD.
	SPD rated voltage is less than system voltage.	Replace SPD with correct voltage model .
	Extended temporary overvoltage (TOV)	Check electrical system for TOV sources, correct, replace SPD.
	Significant surge event	Replace SPD.
One of the display red LEDs is ON. audible alarm is OFF.	Audible alarm silence button has been depressed and alarm is silenced.	Normal operation
		If power is cycled and a fault condition still exists, the audible alarm will reactivate. Replace SPD.
All green and red LEDs are OFF, LCD display (on Surge Counter models) is OFF.	SPD is not connected to a power source.	Check system voltage at SPD connection.
		Check SPD connections.
One phase has neither a green or red LED lit.	Ribbon cable is not connected properly. Ribbon cable is mis-aligned with connector.	Verify ribbon cable and connector are properly aligned and fully seated together.
All phase LEDs are green, audible alarm is on.	Insufficient voltage to the power supply.	Replace SPD.

9.0 Troubleshooting feature package 4, Power Xpert SPD

Many SPD failures result from improper installation. Once the Power Xpert SPD is installed properly, it is a highly reliable unit.

If the SPD does not function properly, first confirm that it is installed properly. See Section 2, "Installation."

If the SPD malfunctions after it has been operating routinely, refer to Table 5. This troubleshooting chart identifies possible causes and solutions to the malfunction. Further assistance may be obtained by calling Eaton's Applications Engineers, at 1-800-809-2772 or email SPD@eaton.com, including being directed to the warranty process if applicable.

Table 5. Troubleshooting chart for Power Xpert SPD

Condition	Probable cause	Solution
Phase LEDs are green (1 per phase) and neu/gnd LED is green	Normal operation	N/A.
Audible alarm OFF, form C (N.C.) contact in the CLOSED state	Normal operation	N/A.
One phase LED is red, audible alarm is ON	Phase protection compromised or lost	Replace SPD
	Extended temporary overvoltage (TOV)	Check electrical system for TOV sources, correct, replace SPD
	Significant surge event	Replace SPD
Neu/gnd LED is red, audible alarm is ON (for models with neutral connections)	Neu/gnd protection is compromised or lost	Replace SPD
	Significant surge event	Replace SPD
All phase LEDs are red, audible alarm is ON	All phase protection has been lost	Replace SPD
	SPD rated voltage is less than system voltage	Replace SPD with correct voltage model
	Extended temporary overvoltage (TOV)	Check electrical system for TOV sources, correct, replace SPD
	Significant surge event	Replace SPD
One of the display LEDs is red, audible alarm is OFF	Audible alarm silence button has been depressed and Alarm is silenced	Normal operation If power is cycled and a fault condition still exists, the audible alarm will reactivate. Replace SPD.
All LEDs are OFF, LCD display is OFF	SPD is not connected to a power source	Check system voltage at SPD connection
		Check SPD connections
One or more phase LED is yellow and neu/gnd LED is green	SPD has lost some protection on the phase with the yellow LED	Monitor SPD, some protection has been lost.
Surge counts are accumulating rapidly	Noise on phase line	Contact an Eaton Customer Support at 1-800-809-2772 or email SPD@eaton.com.
Stuck button error on the local display	One or more of the buttons were depressing during startup.	Clear buttons of any obstructions, if that doesn't resolve the matter contact Eaton Customer Support at 1-800-809-2772 or email SPD@eaton.com.
LCD is turning off/on and there is no communication.	Insufficient input voltage.	Verify phase voltages are within tolerances.
Error "Web page not working".	Available TCP connection limit reached.	Close excess webpage tabs or applications attempting to access port.
BACnet port not communicating.	BACnet setting disabled (default).	Enable BACnet and reboot device.
Modbus port no communicating.	Modbus setting disabled (default).	Enable Modbus and reboot device.
Webpage not secure notice.	Security certificate not installed.	Download and install certificate.
Web UI surge and general logs will not load	Modbus disabled.	Enable Modbus and reboot device.
Time stamps inaccurate.	Clock not synced. Supercap drained of power during extended power loss.	Set clock and use SNTP feature to maintain accurate time stamp.
Any LCD communication setting 'save' initiates a soft reset.	All communication settings modifications require reboot to enable.	Must re-enter settings menu each time a communication setting is changed.

10.0 Specifications

Table 6. Specifications

Description	Specification
Surge current capacity per phase	50, 80, 100, 120, 160, 200, 250, 300, 400 kA ratings available
Nominal discharge current (In)	20kA
Short circuit current rating (SCCR)	200kA
SPD type	Basic feature package = type 1 (can also be used in type 2 applications) Standard, Standard with Surge Counter, and Power Xpert SPD feature packages = type 2
Enclosure types	NEMA 1, NEMA 4, NEMA 4X (304 SST) (Power Xpert SPD not available in NEMA 4X)
Standard split phase voltages available	120/240
Single phase	230
Three phase wye system voltages available	120/208, 127/220, 230/400, 277/480, 347/600
Three phase delta system voltages	240, 480, 600
Three phase high leg delta system voltages	120/240
Phase wire length	48" of 10AWG extend beyond the conduit hub
Relay wire length (optional)	48" of 14AWG extend beyond the conduit hub
RoHS compliant	Yes
Internal disconnect (optional)	Eaton 30 Amp FDC circuit breaker, type MCCB
Input power frequency	50/60 Hz, Power Xpert SPD tested to 60 Hz only
Power consumption (Basic units)	
208Y, 220Y, 230L, 240S, 240D, and 240H voltage codes	0.5W
400Y and 480Y and 480D voltage codes	1.1W
600Y and 600D voltage codes	1.3W
Power consumption (Standard and Standard with Surge Counter units)	
208Y, 220Y, 230L, 240S, 240D, and 240H voltage codes	0.6W
400Y, 480Y, and 480D Basic voltage codes	1.7W
600Y and 600D voltage codes	2.1W
Power consumption (Power Xpert SPD units)	
208Y, 220Y, 240S, 240D, and 240H voltage codes	4W
400Y, 480Y, and 480D Basic voltage codes	4W
600Y and 600D voltage codes	4W
Phase protection	Single split phase..L-N, L-G, N-G, L-L Single phase .L-N, L-G, N-G Three phase delta L-G, L-L Three phase wye L-N, L-G, N-G, L-L Three phase high leg delta L-N, L-G, N-G, L-L, H-N, H-G, H-L
Maximum continuous operating voltage (MCOV)	
208Y, 220Y, 240S voltage codes	150 L-N,300 L-G,150 N-G,300 L-L
230L	320 L-N,640 L-G,320 N-G
240H	150 L-N,300 L-G,150 N-G,300 L-L,320 H-N,470 H-G,470 H-L
400Y and 480Y voltage codes	320 L-N,640 L-G,320 N-G,640 L-L
600Y voltage code	420 L-N,420 L-G,420 N-G,840 L-L
240 D voltage code	300 L-G,300 L-L
480 D voltage code	640L- L-G, 640 L-L
600D voltage code	840 L-G,840 L-L
Ports	1
Operating temperature	-40° F to 122° F (-40°C to 50° C), Power Xpert SPD surge protection (-40°C to 50°C) Power Xpert LCD module (-20°C to 70°C)
Operating humidity	5% through 95%, non-condensing

Table 6. Specifications (cont.)

Description	Specification
Operating altitude	Up to 16,000 ft (5000 m), (Power Xpert SPD up to 6561 ft (2000 m))
Weight	Reference Figures 2 - 6 on pages 4 - 6
Form C relay contact ratings	150 Vac @ 0.46 A or 30 Vdc @ 1A, terminal block rated 300V, 16A suitable for use with 30-12 AWG solid or stranded copper wire. Torque 5-7 lbs-in.
Form C relay contact logic	Power on, normal state - NO contact = OPEN, NC contact = CLOSED Power off, fault state, - NO contact = CLOSED, NC contact = OPEN
Real time clock accuracy, Power Xpert SPD	Synchronized when connected to a network via an ethernet cable, +/- 2 min/month @ 25°C when not connected to a network
EMI/RFI filtering attenuation (Standard and Standard with Surge Counter and Power Xpert SPD)	Up to 50 dB from 10 kHz to 100 MHz
Ethernet port	Data rate 10/100 Mbps, wire type: equal or exceed 5 UTP category 5, use of STP (shielded twisted pair) will improve EMI performance. Connector type: RJ45 modular, ground metal shield
Agency certifications and approvals Feature packages 1, 2, and 3	UL1449 4th Edition listed, CSA (excludes 230L voltage code), UL1283 7th Edition (type 2 SPDs only) IEC 61643-11/EN 61643-11, Part 11: Test Class II. See Section 11.0 Ordering guidelines for specific models.
Agency certifications and approvals Feature package 4 (Power Xpert SPD)	cULus certified, UL1449 4th Edition listed, UL1283 7th Edition IEC 61643-11/EN 61643-11, Part 11: Test Class II. See Section 11.0 Ordering guidelines for specific models.
Warranty	10 years, 15 years if you register on www.eaton.com/spd and then click the warranty registration icon.
ROHS compliant	Yes
Wire length and AWG	Factory prewired with 48 inches of #10 AWG wire.

11.0 Ordering guidelines

Table 7. Eaton SPD Series

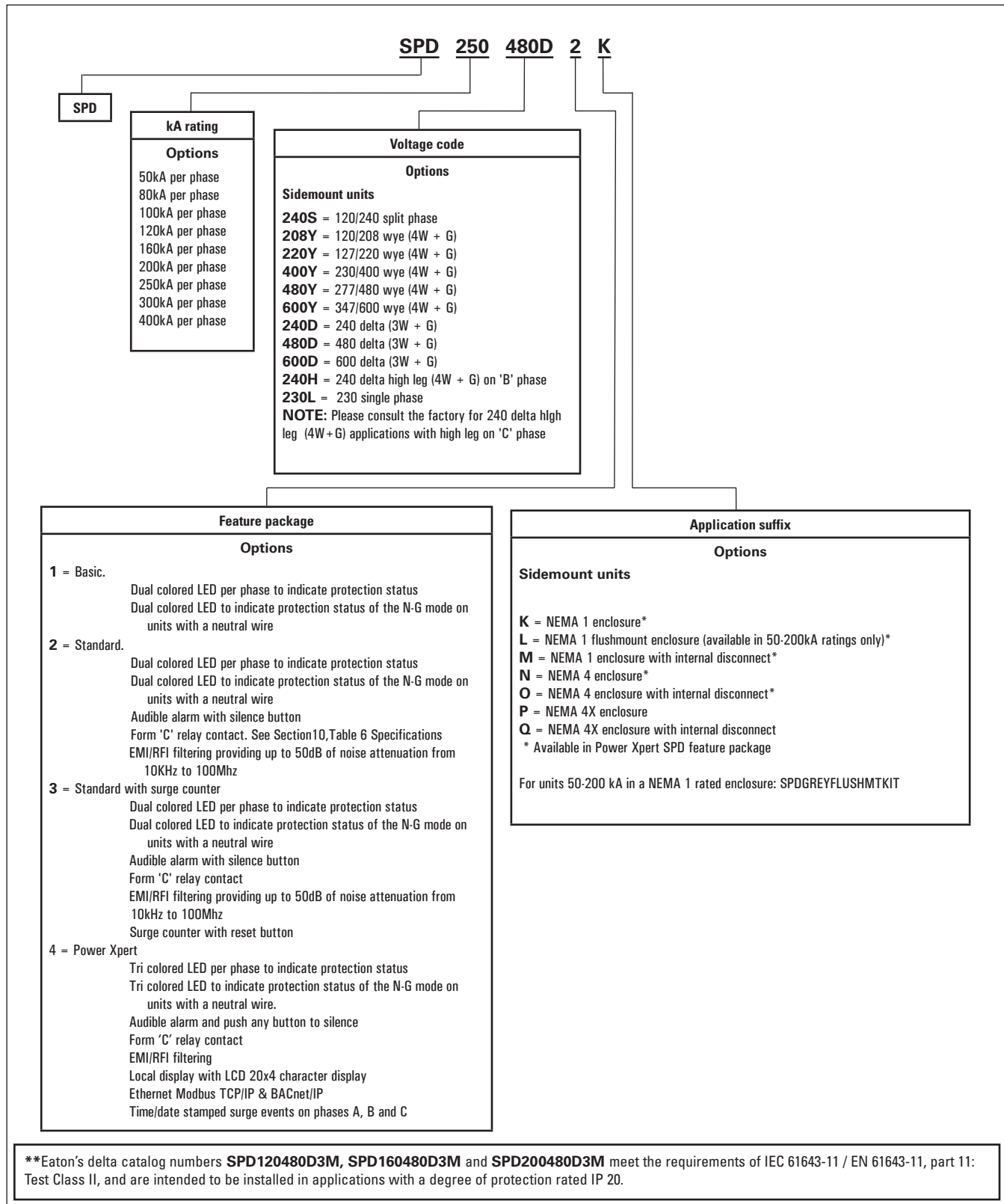

Example: SPD 250480D2K = SPD Series, 250kA per phase, 480D voltage, standard feature package, NEMA 1 sidemount application.

12.0 Warranty

Eaton warrants these products for a period of 10 years from the date of delivery to the purchaser, 15 years if you register on www.eaton.com/spd and click the warranty registration icon to be free from defects in both workmanship and materials. Eaton assumes no risk or liability for results of the use of the products purchased from it, including but without limiting the generality of the foregoing: (1) The use in combination with any electrical or electronic components, circuits, systems, assemblies, or any other materials or substances; (2) Unsuitability of any product for use in any circuit or assembly.

Purchaser's rights under the warranty shall consist solely of requiring Eaton to repair, or at Eaton's sole discretion, replace, free of charge, F.O.B. factory, and defective items received at said factory within said term determined by Eaton to be defective. The giving of or failure to give any advice or recommendations by Eaton shall not constitute any warranty by or impose any liability upon Eaton. The foregoing constitutes the sole and exclusive liability of Eaton AND IS IN LIEU OF ANY AND ALL OTHER WARRANTIES EXPRESSED, IMPLIED OR STATUTORY AS TO THE MERCHANTABILITY, FITNESS FOR PURPOSE SOLD, DESCRIPTION, QUALITY, PRODUCTIVENESS OR ANY OTHER MATTER.

In no event shall Eaton be liable for special or consequential damages or for delay in performance of the warranty.

This warranty does not apply if the product has been misused, abused, altered, tampered with, or used in applications other than specified on the nameplate. At the end of the warranty period, Eaton shall be under no further warranty obligation expressed or implied.

The product covered by this warranty certificate can only be repaired or replaced by the factory. For help on troubleshooting the SPD, or for warranty information, call 1-800-809-2772, Option 4, sub-option 2. Repair or replacement units will be returned collect. If Eaton finds the return to be a manufacturer's defect, the product will be returned prepaid.

Copyright © 2019 by Eaton, Moon Township, PA, USA. All rights reserved. No part of this document may be reproduced in any way without the express written approval of Eaton.

Specifications contained herein are subject to change without notice.

EATON - CONFIDENTIAL AND PROPRIETARY NOTICE TO PERSONS RECEIVING THIS DOCUMENT AND/OR TECHNICAL INFORMATION IN THIS DOCUMENT, INCLUDING THE DRAWING AND INFORMATION CONTAINED THEREON, IS CONFIDENTIAL AND IS THE EXCLUSIVE PROPERTY OF EATON, AND IS MERELY ON LOAN AND SUBJECT TO RECALL BY EATON AT ANY TIME. BY TAKING POSSESSION OF THIS DOCUMENT, THE RECIPIENT ACKNOWLEDGES AND AGREES THAT THIS DOCUMENT CANNOT BE USED IN ANY MANNER ADVERSE TO THE INTERESTS OF EATON, AND THAT NO PORTION OF THIS DOCUMENT MAY BE COPIED OR OTHERWISE REPRODUCED WITHOUT THE PRIOR WRITTEN CONSENT OF EATON. IN THE CASE OF CONFLICTING CONTRACTUAL PROVISIONS, THIS NOTICE SHALL GOVERN THE STATUS OF THIS DOCUMENT.

DISCLAIMER OF WARRANTIES AND LIMITATION OF LIABILITY

The information, recommendations, descriptions and safety notations in this document are based on Eaton's ("Eaton") experience and judgment and may not cover all contingencies. If further information is required, an Eaton sales office should be consulted. Sale of the product shown in this literature is subject to the terms and conditions outlined in appropriate Eaton selling policies or other contractual agreement between Eaton and the purchaser. THERE ARE NO UNDERSTANDINGS, AGREEMENTS, WARRANTIES, EXPRESSED OR IMPLIED, INCLUDING WARRANTIES OF FITNESS FOR A PARTICULAR PURPOSE OR MERCHANTABILITY, OTHER THAN THOSE SPECIFICALLY SET OUT IN ANY EXISTING CONTRACT BETWEEN THE PARTIES. ANY SUCH CONTRACT

STATES THE ENTIRE OBLIGATION OF EATON. THE CONTENTS OF

THIS DOCUMENT SHALL NOT BECOME PART OF OR MODIFY ANY CONTRACT BETWEEN THE PARTIES.

In no event will Eaton be responsible to the purchaser or user in contract, in tort (including negligence), strict liability or otherwise for any special, indirect, incidental or consequential damage or loss whatsoever, including but not limited to damage or loss of use of equipment, plant or power system, cost of capital, loss of power, additional expenses in the use of existing power facilities, or claims against the purchaser or user by its customers resulting from the use of the information, recommendations and descriptions contained herein.

Appendix A
 Power Xpert SPD local display menu map - surge events

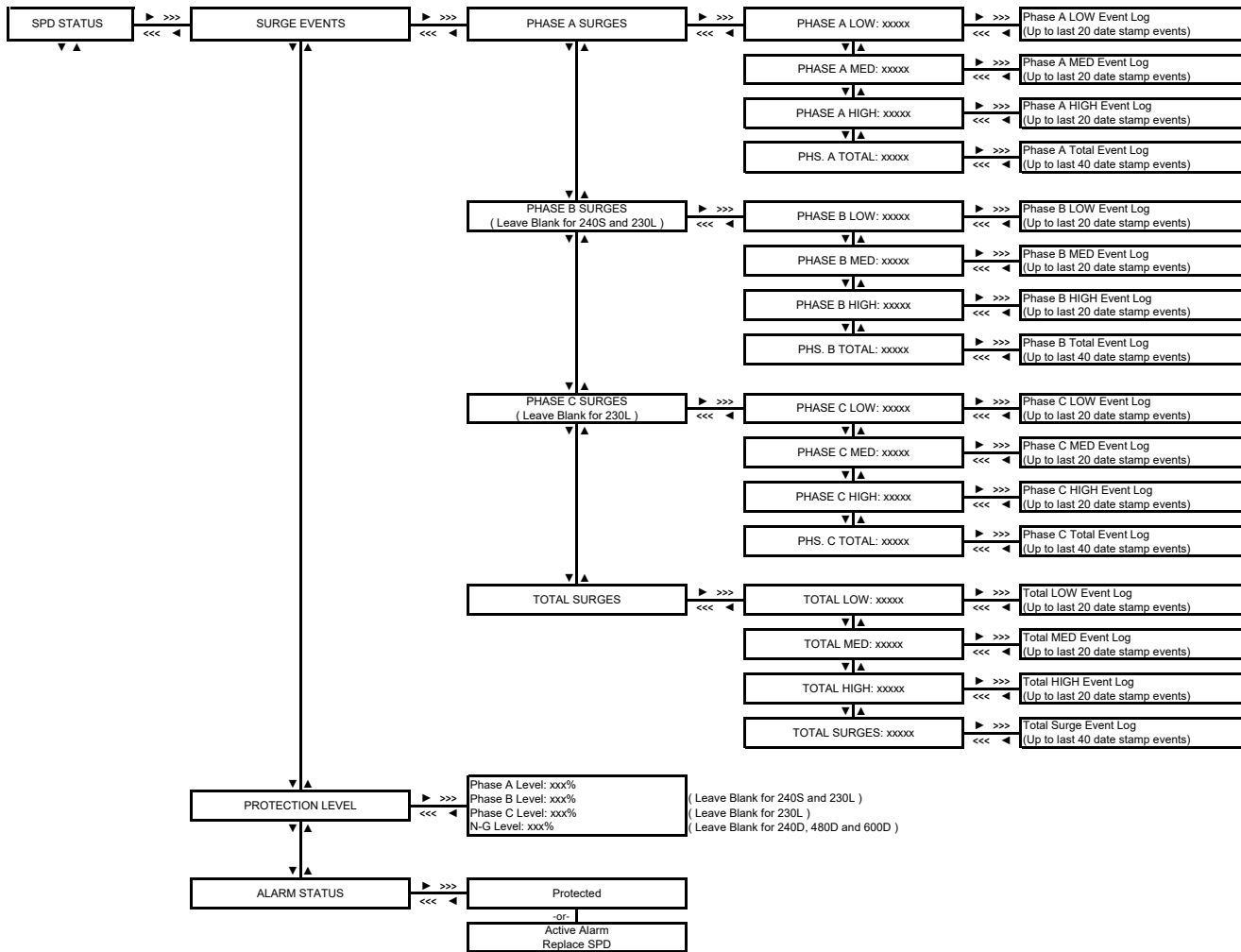

Appendix B
 Power Xpert SPD local display menu map - event log

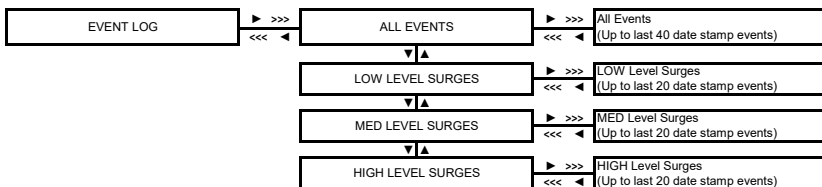

Appendix C Power Xpert SPD local display menu map - settings

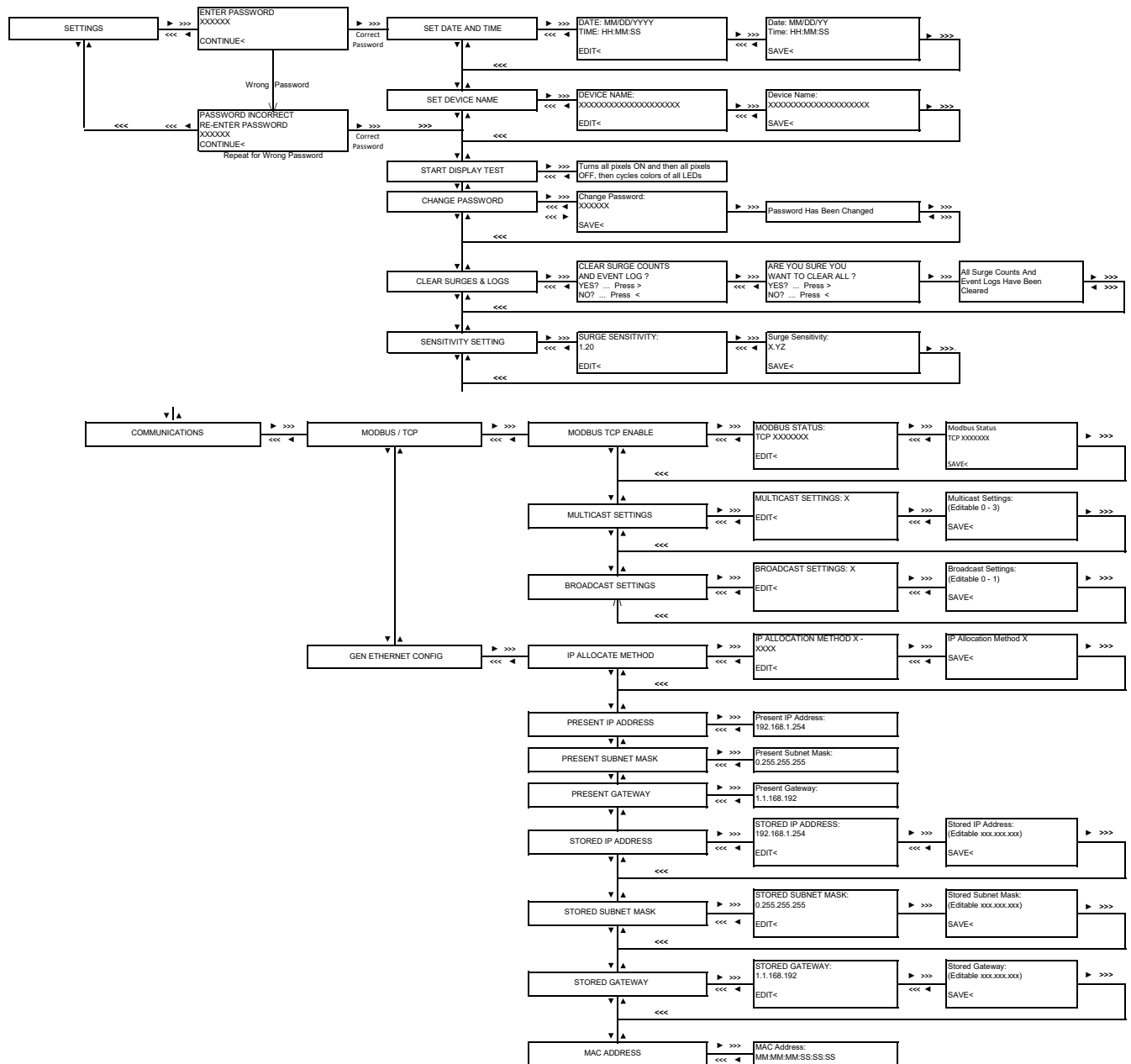

Appendix D
Power Xpert SPD local display menu map - identification

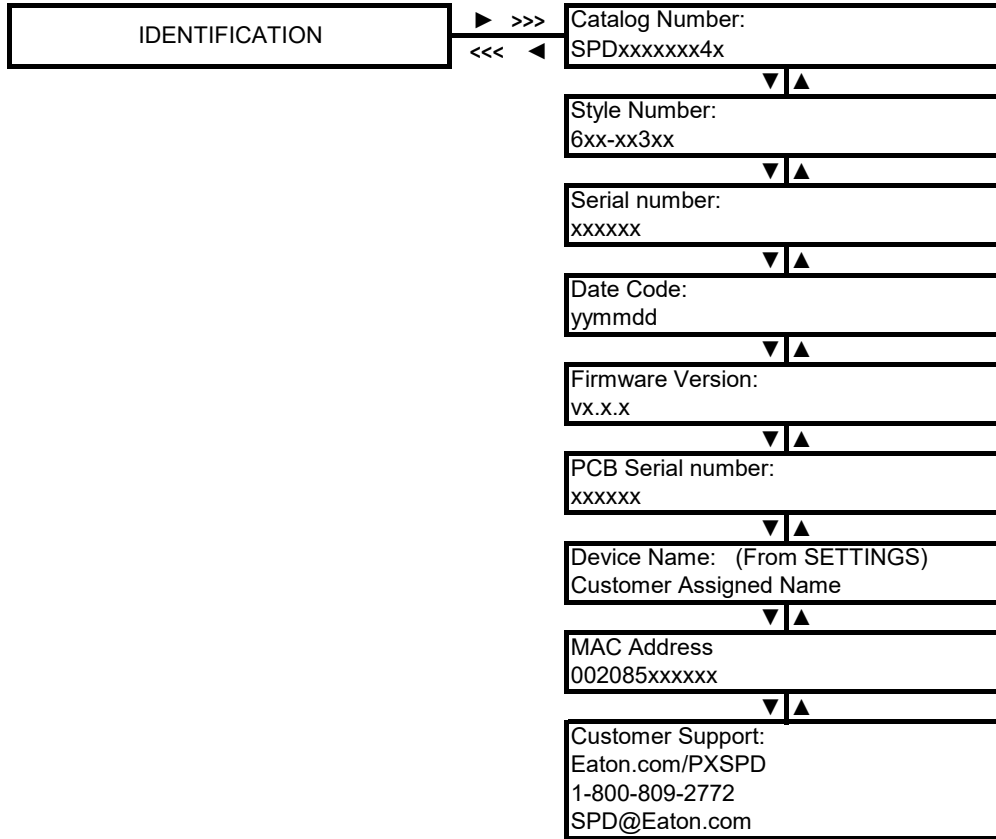

Appendix E

Power Xpert SPD local display - test sequence



1. All LEDs turn red



2. All LEDs turn yellow



3. All LEDs turn green



4. Alarm will sound momentarily.



5. Alarm turns off



6. Half pixels turn on



7. Other half of pixels turn on



8. All pixels turn on



9. LEDs turn red again.



10. Test completed

Appendix F: Power Xpert SPD Modbus register map

Power Xpert SPD Modbus register map

Register	Name	Attributes	Description
1	Product Serial Number	UINT32 RO NV	32bit device serial number. (MAE)
3	Vendor Name	STRING8 RO Array size: 12	Product vendor name character string Array of 6 registers
14	Vendor URL	STRING8 RO Array size: 14	Product vendor URL Array of 7 registers
37	Style Number	STRING8 RO NV Array size: 10	Product style number (MAE) Array of 5 registers
42	Assigned Name	STRING8 RW NV Array size: 21 Default: "SPDLAB1"	User assigned name Array of 11 registers
53	Firmware Revision	STRING8 RO Array size: 14	Firmware revision Array of 7 registers
60	PCB Serial Number	STRING8 RO NV Array size: 14	Product hardware revision numerical (MAE) Array of 7 registers
77	Method of IP Allocation	UINT8 RW NV	Allows to set the method used to allocate an IP address: 0 - restore (hardcoded 192.168.1.254), 1 - DHCP, 2 -full address taken from NV memory.
		Default: 0	Value Description
		Enum	0 Statically hardcoded
			1 DHCP allocated
			2 Taken from NV
78	Current Method of IP Allocation	UINT8 RO Range: 0 to 3	Shows the present method used to allocate an IP address: 0 - restore (hardcoded 192.168.1.254), 1 - DHCP, 2 - full address taken from NV memory.
79	Present Ethernet IP Address	UINT8 RO Array size: 4 Units: IP	The active IP address being used on the network. Array of 2 registers IPV4_BIG_ENDIAN_U8()
81	Present Ethernet Subnet Mask	UINT8 RO Array size: 4 Units: IP	The active subnet mask IP address being used on the network. Array of 2 registers IPV4_BIG_ENDIAN_U8()
83	Present Ethernet Default Gateway	UINT8 RO Array size: 4 Units: IP	The active default gateway IP address being used on the network. Array of 2 registers IPV4_BIG_ENDIAN_U8()
85	Stored Ethernet IP Address	UINT8 RW NV Array size: 4 Default: 0xFE, 0x01, 0xA8, 0xC0 Units: IP	The IP address used in the NV address select configuration. Array of 2 registers IPV4_BIG_ENDIAN_U8()
87	Stored Ethernet Subnet Mask	UINT8 RW NV Array size: 4 Default: 0x00, 0xFF, 0xFF, 0xFF Units: IP	The IP subnet mask used in the NV address select configuration. Array of 2 registers IPV4_BIG_ENDIAN_U8()
89	Stored Ethernet Default Gateway	UINT8 RW NV Array size: 4 Default: 0x01, 0x01, 0xA8, 0xC0 Units: IP	The IP default gateway used in the NV address select configuration. Array of 2 registers IPV4_BIG_ENDIAN_U8()
98	Multicast Enable Disable (00000010)	UINT32 RW NV Default: 0x00000010	Multicast settings: Value : Description 0x00000010: Multicast Enable 0x00000000: Multicast Disable with Filter PerfectFilter 0x00000004: Multicast Disable with Filter HashTable 0x00000404: Multicast Disable with Filter_PerfectHashTable
100	Broadcast Enable Disable (0)	UINT32 RW NV	Broadcast Enable Disable settings: 0x00000000: BroadcastFramesReception_Enable 0x000020: BroadcastFramesReception_Disable
102	Modbus TCP Com Timeout (0)	UINT16 RW NV Default: 0 Units: milliseconds	Communication timeout for Modbus TCP. 0 = disable.

Power Xpert SPD Modbus register map (cont.)

Register	Name	Attributes	Description
122	DHCP to Static IP addr lock (0)	BOOL RW NV Default: FALSE Range: FALSE to TRUE	
127	Set Time	UINT32 RW Default: 946684800	32 bit epoch time from RTC
129	RTC Time	UINT32 RO Default: 0x0034220A	Real time clock time in hh:mm:ss format (24 hour format)
187	Sensitivity	UINT8 RW NV Default: 25 Range: 25 to 50	Threshold value for considering the valid low surge count should be in the range of 1.0 to 2.0 ms.
188	Phase A High Surge Count	UINT32 RO Default: 0 Range: 0 to 99999	Number of high surge occurred in phase A
190	Phase A Medium Surge Count	UINT32 RO Default: 0 Range: 0 to 99999	Number of medium surge occurred in phase A
192	Phase A Low Surge Count	UINT32 RO Default: 0 Range: 0 to 99999	Number of low surge occurred in phase A
194	Phase B High Surge Count	UINT32 RO Default: 0 Range: 0 to 99999	Number of high surge occurred in phase B
196	Phase B Medium Surge Count	UINT32 RO Default: 0 Range: 0 to 99999	Number of medium surge occurred in phase B
198	Phase B Low Surge Count	UINT32 RO Default: 0 Range: 0 to 99999	Number of low surge occurred in phase B
200	Phase C High Surge Count	UINT32 RO Default: 0 Range: 0 to 99999	Number of high surge occurred in phase C
202	Phase C Medium Surge Count	UINT32 RO Default: 0 Range: 0 to 99999	Number of medium surge occurred in phase C
204	Phase C Low Surge Count	UINT32 RO Default: 0 Range: 0 to 99999	Number of low surge occurred in phase C
206	Low Surge Event Time Stamp	UINT32 RO Array size: 2000 Default: 0	Stores the timestamp of low surge event. Timestamp will be stored in epoch time. Time stamp can be verified using register 123 Array of 4000 registers
4206	Low Surge Event Phase Indicator	UINT8 RO Array size: 2000 Default: 0 Enum	Indicates in which the phase, low surge event occurred. Value Description 1 Phase A low surge event log 2 Phase B low surge event log 3 Phase C low surge event log
5206	Low Surge Event Log Index	UINT16 RO Default: 0 Range: 0 to 2000	Index points to the latest low surge event log
5207	Medium Surge Event Time Stamp	UINT32 RO Array size: 1500 Default: 0	Stores the timestamp of medium surge event. Timestamp will be stored in epoch time. Array of 3000 registers

Power Xpert SPD Modbus register map (cont.)

Register	Name	Attributes	Description
8207	Medium Surge Event Phase Indicator	UINT8 RO	Indicates in which the phase, medium surge event occurred.
		Array size: 1500	Value Description
		Default: 0	1 Phase A medium surge event log
		Enum	2 Phase B medium surge event log
			3 Phase C medium surge event log
8957	Medium Surge Event Log Index	UINT16 RO	Index points to the latest medium surge event log
		Default: 0	
		Range: 0 to 1500	
8958	High Surge Event Time Stamp	UINT32 RO	Stores the timestamp of high surge event. Timestamp will be stored in epoch time
		Array size: 1000	Array of 2000 registers
		Default: 0	
10958	High Surge Event Phase Indicator	UINT8 RO	Indicates in which the phase, medium surge event occurred.
		Array size: 1000	Value Description
		Default: 0	1 Phase A high surge event log
		Enum	2 Phase B high surge event log
			3 Phase C high surge event log
11458	High Surge Event Log Index	UINT16 RO	Index points to the latest high surge event log
		Default: 0	
		Range: 0 to 1000	
11459	Clear Surge Log Events	BOOL RW NV	Clear the high, medium and low surge event logs in phase A, B and C 1. Default value is zero 2. Writing 1 to the register will clear the surge logs.
		Default: 0	
		Range: 0 to 1	
11460	Clear Surge Counts	BOOL RW NV	Clear the high, medium and low surge counts in phase A, B and C 1. Default value is zero 2. Writing 1 to the register will clear the surge counts.
		Default: 0	
		Range: 0 to 1	
11461	Indicates Power Xpert SPD System faults	DWORD RO	Power Xpert SPD system fault indication to user
		Default: 0	Bit Description Coil
		Bitfield	0 No faults n/a
			1 Error in logging data to FRAM n/a
			2 NV memory checksum error n/a
11463	Total Low Surge Counts	UINT32 RO	Indicates total low surges occurred. This will be sum of phase A, phase B and phase C low surge counts
		Default: 0	
		Range: 0 to 999999	
11465	Total Medium Surge Counts	UINT32 RO	Indicates total medium surges occurred. This will be sum of phase A, phase B and phase C medium surge counts
		Default: 0	
		Range: 0 to 999999	
11467	Total High Surge Counts	UINT32 RO	Indicates total high surges occurred. This will be sum of phase A, phase B and phase C high surge counts
		Default: 0	
		Range: 0 to 999999	
11469	Sum of Surge Counts of All Phases	UINT32 RO	Indicates the total surge counts, This will be sum of low, medium and high surges
		Default: 0	
		Range: 0 to 999999	
11476	Power Xpert SPD Firmware Version ASCII	STRING8 RO	Power Xpert SPD firmware in the format of major & minor.
		Array size: 6	Array of 3 registers
11479	Date Code	STRING8 RO NV	Date code as determined by test station, format : "yymmdd". (MAE)
		Array size: 7	Array of 4 registers
11483	Catalog Number	STRING8 RO NV	Catalog number assigned to the product. (MAE)
		Array size: 20	Array of 10 registers
11497	Indicates the status of N-G Green LED	BOOL RO	Indicates the status of N-G green LED, 0:LED off 1:LED on. Indicates protection status on N-G
11498	Indicates the status of N-G Yellow LED	BOOL RO	Indicates the status of N-G yellow LED, 0:LED off 1:LED on. Indicates protection status on N-G

Power Xpert SPD Modbus register map (cont.)

Register	Name	Attributes	Description
11499	Indicates the status of N-G Red LED	BOOL RO Default: 0	Indicates the status of N-G red LED, 0:LED off 1:LED on. Indicates protection status on N-G
11500	Indicates the status of Phase A Green LED	BOOL RO Default: 0	Indicates the status of phase-A green LED, 0:LED off 1:LED on. Indicates protection status on phase-A
11501	Indicates the status of Phase A Yellow LED	BOOL RO Default: 0	Indicates the status of phase-A yellow LED, 0:LED off 1:LED on. Indicates protection status on phase-A
11502	Indicates the status of Phase A Red LED	BOOL RO Default: 0	Indicates the status of phase-A red LED, 0:LED off 1:LED on. Indicates protection status on phase-A
11503	Indicates the status of Phase B Green LED	BOOL RO Default: 0	Indicates the status of phase-B green LED, 0:LED off 1:LED on. Indicates protection status on phase-B
11504	Indicates the status of Phase B Yellow LED	BOOL RO Default: 0	Indicates the status of phase-B yellow LED, 0:LED off 1:LED on. Indicates protection status on phase-B
11505	Indicates the status of Phase B Red LED	BOOL RO Default: 0	Indicates the status of phase-B red LED, 0:LED off 1:LED on. Indicates protection status on phase-B
11506	Indicates the status of Phase C Green LED	BOOL RO Default: 0	Indicates the status of phase-C green LED, 0:LED off 1:LED on. Indicates protection status on phase-C
11507	Indicates the status of Phase C Yellow LED	BOOL RO Default: 0	Indicates the status of phase-C yellow LED, 0:LED off 1:LED on. Indicates protection status on phase-C
11508	Indicates the status of Phase C Red LED	BOOL RO Default: 0	Indicates the status of phase-C red LED, 0:LED off 1:LED on. Indicates protection status on phase-C
11509	Alarm status	UINT8 RO Default: 0 Enum	Power Xpert SPD alarm status, alarm is used to indicate protection status Value Description 0 Alarm OFF 1 Alarm ON
11510	Percentage of protection on N-G	UINT16 RO Default: 0	Percentage of protection available on NG
11511	Percentage of protection on Phase A	UINT16 RO Default: 0	Percentage of protection available on phase A
11512	Percentage of protection on Phase B	UINT16 RO Default: 0	Percentage of protection available on phase B
11513	Percentage of protection on Phase C	UINT16 RO Default: 0	Percentage of protection available on phase C
11514	Silences the Alarm. Setting the value, will silence the Alarm	BOOL RW Default: 0	Silences the Alarm. Setting the value, will silence the alarm
11515	Ambient temperature of SPD device	FLOAT RO Default: 0	Ambient temperature in Celsius
11517	General log Indicator	UINT16 RO Array size: 250 Default: 0 Enum	General log Indicator Value Description 0 No event occurred 1 Protection reduced on phase A 2 Protection reduced on phase B 3 Protection reduced on phase C 4 Protection reduced on neutral ground 5 Protection loss on phase A 6 Protection loss on phase B 7 Protection loss on phase C 8 Protection loss on phase neutral ground 9 Alarm silenced 10 SPD powered off 11 SPD powered on
11767	General log Timestamp	UINT32 RO Array size: 250 Default: 0	Stores the timestamp of general log events. Timestamp will be stored in epoch time.. Array of 500 registers

Power Xpert SPD Modbus register map (cont.)

Register	Name	Attributes	Description
12267	General log Index	UINT16 RO Default: 0 Range: 0 to 250	Index points to the latest general event log
12268	Clear General Log Events	BOOL RW NV Default: 0 Range: 0 to 1	Clear general event logs 1. Default value is zero 2. Writing 1 to the register will clear the general logs.
12269	Phase A Total Surge Counts	UINT32 RO Default: 0 Range: 0 to 999999	Sum of phase A high, medium and low surge counts
12271	Phase B Total Surge Counts	UINT32 RO Default: 0 Range: 0 to 999999	Sum of phase B high, medium and low surge counts
12273	Phase C Total Surge Counts	UINT32 RO Default: 0 Range: 0 to 999999	Sum of phase C high, medium and low surge counts
12275	DCI for Testing Display	BOOL RW Default: 0 Range: 0 to 1	DCI test display, LED and alarm. Setting the value starts the display test, once the display test is complete the value will be updated to zero by the firmware
12276	Ethernet MAC Address	UINT8 RO NV Array size: 6	Unique MAC address assigned to this device.(MAE) Array of 3 registers MAC_ADDRESS()

Appendix G
Web user error codes

Error Message	Description	Action Required
Login Failed (Login Page)	User not authorized to access device	Contact administrator for authorization
One Admin Role is mandatory in System		
User Self-Deletion Not Permitted		Contact administrator to delete user
Username Already Exists	Username already exists on the device	Create unique username
User Database Full		
Password Security Violation		
Password Matches With Name or Existing Password	Username and password match	Create unique username and password New password cannot match old password
User Locked Temporarily	Too many users trying to access device	
HTTP Version Not Supported		
Failed to Fetch	Device communication failed (login page), device communication failure (firmware update page)	
Codepack integrity check has failed	Image in the codepack file is corrupt	Re-install firmware
Codepack integrity check has aborted firmware update	Displayed when any one image is corrupt during multiple firmware update	Re-install firmware
Final integrity check is invalid	Multiple reasons	

Appendix H BACnet map

Analog objects

Instance	Object name	Object description	Object type	Unit	Access type	COV increment
0	Sensitivity	Surge sensitivity	AV	No unit	R/W	1
1	Phase A High Surge Count	Phase A high surge count	AV	No unit	RO	1
2	Phase A Medium Surge Count	Phase A medium surge count	AV	No unit	RO	1
3	Phase A Low Surge Count	Phase A low surge count	AV	No unit	RO	1
4	Phase B High Surge Count	Phase B high surge count	AV	No unit	RO	1
5	Phase B Medium Surge Count	Phase B medium surge count	AV	No unit	RO	1
6	Phase B Low Surge Count	Phase B low surge count	AV	No unit	RO	1
7	Phase C High Surge Count	Phase C high surge count	AV	No unit	RO	1
8	Phase C Medium Surge Count	Phase C medium surge count	AV	No unit	RO	1
9	Phase C Low Surge Count	Phase C low surge count	AV	No unit	RO	1
10	Phase A % Protection	Percentage of protection available on phase A	AV	No unit	RO	1
11	Phase B % Protection	Percentage of protection available on phase B	AV	No unit	RO	1
12	Phase C % Protection	Percentage of protection available on phase C	AV	No unit	RO	1
13	Phase N-G % Protection	Percentage of protection available on NG	AV	No unit	RO	1
14	Phase A Total Surge Counts	Phase A total surge counts	AV	No unit	RO	1
15	Phase B Total Surge Counts	Phase B total surge counts	AV	No unit	RO	1
16	Phase C Total Surge Counts	Phase C total surge counts	AV	No unit	RO	1
17	RTC Time	RTC time	AV	No unit	RO	1
18	Set Time	Set time	AV	No unit	R/W	1
19	Total Low Surge Counts	Total low surge counts	AV	No unit	RO	1
20	Total Medium Surge Counts	Total medium surge counts	AV	No unit	RO	1
21	Total High Surge Counts	Total high surge counts	AV	No unit	RO	1
22	Total Surge Counts	Total surge counts	AV	No unit	RO	1
23	System Faults	System faults	AV	No unit	RO	1
24	Method of IP Allocation	Allows to set the method used to allocate an IP address	AV	No unit	R/W	1

Binary objects

Instance	Object name	Object description	Objecttype	Inactive text	Active text	Access type
0	Clear Surge Log Events	Clear surge log events	BV	OFF	ON	R/W
1	Clear Surge Counts	Clear surge counts	BV	OFF	ON	R/W
2	Phase A Green Led Status	Phase A green led status	BV	OFF	ON	RO
3	Phase A Yellow Led Status	Phase A yellow led status	BV	OFF	ON	RO
4	Phase A Red Led Status	Phase A red led status	BV	OFF	ON	RO
5	Phase B Green Led Status	Phase B green led status	BV	OFF	ON	RO
6	Phase B Yellow Led Status	Phase B yellow led status	BV	OFF	ON	RO
7	Phase B Red Led Status	Phase B red led status	BV	OFF	ON	RO
8	Phase C Green Led Status	Phase C green led status	BV	OFF	ON	RO
9	Phase C Yellow Led Status	Phase C yellow led status	BV	OFF	ON	RO
10	Phase C Red Led Status	Phase C red led status	BV	OFF	ON	RO
11	NG Green Led Status	NG green led status	BV	OFF	ON	RO
12	NG Yellow Led Status	NG yellow led status	BV	OFF	ON	RO
13	NG Red Led Status	NG red led status	BV	OFF	ON	RO
14	Alarm status	Alarm status	BV	Protected	Protection loss	RO
15	Silences Alarm	Silences the alarm	BV	Silence?	Silenced	R/W
16	Clear General Log	Clear general log	BV	OFF	ON	R/W

AV = Analog Value

BV = Binary Value

Appendix H

BACnet map (Cont.)

Device objects

Object name	Object type	Access type
Product Vendor Name	DEV	RO
BACnet Vendor Identifier	DEV	RO
Style Name	DEV	RO
BACnet Max Master	DEV	RO
BACnet Max Info Frames	DEV	RO
BACnet Profile Name	DEV	RO
User Application Name or Device Tag	DEV	RO
Product Name - Short description of Prod Code	DEV	RO

Notes:

Eaton
Electrical Sector
1000 Eaton Boulevard
Cleveland OH 44122
United States
877-ETN-CARE (877-386-2273)
Eaton.com

© 2020 Eaton
All Rights Reserved
Printed in USA
Publication No. IM01005031E TBG01131
December 2020



Eaton is a registered trademark.

All other trademarks are property of their
respective owners.