

# GENERAL NOTES:

- The Contractor shall comply with all applicable safety regulations. All construction shall be completed following current City Standard Specifications and Special Provisions.
- Contractor will be required to provide notice to utility companies a minimum of seventy-two (72) hours prior to any excavation, as follows:

Kansas One-Call 687-2470

The Contractor must notify the following in case of an emergency:

AT&T 1-800-246-8464  
 Black Hills Energy 1-800-694-8989  
 City of Wichita Water 1-316-268-4555  
 City of Wichita Sewer 1-316-268-4073  
 City of Wichita Stormwater 1-316-268-4090  
 City of Wichita Traffic 1-316-268-4034  
 Cox Communications 1-888-249-3530  
 Kansas Gas Service 1-888-482-4950  
 Westar Energy 1-800-544-4857  
 Southern Star Central Gas Pipeline 1-316-303-7800

- Utility service lines, poles, etc. are to be adjusted as necessary by others prior to construction unless the plans specifically call for their adjustment by the Contractor or unless the plans specifically identify a utility to be adjusted by its owner during construction. Existing utilities and their location, as shown on the plans, represent the best information obtainable for design. The Contractor will be required to work around existing utilities within the right-of-way which do not conflict with proposed construction.

- Rubble from the removal of miscellaneous structures and excess excavation which is to be wasted shall be disposed of on sites to be provided by the Contractor. These sites shall be approved by the Engineer as to suitability, appearance and site location. Locations, in the opinion of the Engineer, that will leave an unsightly appearance will not be approved. All disposal sites must be approved by the Kansas Department of Health and Environment. Material either stockpiled or disposed of in a flood plain will require a Kansas State Board of Agriculture permit. Any material dumped in waters of the United States or wetlands is subject to U.S. Corps of Engineers permitting regulations. Any material buried or stockpiled beyond approved construction limits will require additional archaeological investigations unless buried in a previously approved borrow location.

- Trees and shrubs in public right-of-way which are in direct conflict with proposed new construction shall be removed by the Contractor with the City Engineer's approval. Trees and shrubs which are not in direct conflict with proposed new construction shall be saved and protected from damage.

- The Contractor shall give all property owners and/or tenants of developed property abutting the construction of this project a minimum of ten (10) days notice prior to start of construction.

- The Contractor shall be responsible for preserving property irons. The Contractor will be required to re-establish any property irons which are damaged or destroyed by his construction operations. Such irons shall be re-established by a licensed land surveyor in accordance with state laws.

- The Engineering Division shall field locate water valves one time during construction when requested by the Contractor. It shall be the Contractor's responsibility to preserve such field locations during the construction process. Water valves, valve boxes or fire hydrants damaged during construction shall be repaired by Contractor at his own expense. Valve boxes and water meters within the project limits shall be adjusted to match field grades by the Contractor.

- The Contractor shall notify the consultant engineer and Tom Mason with the City at 316-268-4574 with the anticipated construction start date and notify them of project completion. Staking and inspection for this project will be the responsibility of the Contractor.

- If traffic will be impacted by construction, a traffic control plan must be submitted and approved by the City Traffic Engineer, Brian Coon at [traffic@wichita.gov](mailto:traffic@wichita.gov) before construction can begin. The Contractor shall be responsible for all traffic control measures to facilitate construction. All construction zone markings and signage shall conform to the latest version of the Manual on Uniform Traffic Control Devices (MUTCD) as published by the US Dept. of Transportation, Federal Highway Administration. All costs associated with construction markings and signage shall be the Contractor's responsibility.

- All elevations shown are NAVD 88.

- All areas disturbed during construction that will not be under proposed pavement shall be restored to match existing conditions.

- Any sidewalk, drive approach, curb, or street pavement removed to construct project must have a pavement cut permit and be replaced by the City contractor. Permits can be obtained by calling 316-268-4501 or 316-268-4480.
- City Maintenance of storm sewer ends at the last structure in the easement or right-of-way.
- A portion of excess excavated material shall be mounded around manholes which extend more than one (1) foot above the existing ground. Such mound shall be constructed with new development a six (6) foot diameter flat top with 4 to 1 side slopes down to the original ground. The elevation of the flat top of the mound shall be 0.4 foot below the top to the manhole.
- Geotechnical report available upon request.
- Contractor shall limit the extent of trench openings overnight and weekends to less than 50 feet.
- The inspecting firm shall submit to the City Stormwater Maintenance Division a digital copy of the CCTV inspection of the conduits and structures following construction. The digital file formation shall be compatible with the City input template. A copy of the template is available upon request at 316-268-4090.
- The Contractor shall protect from damage and support existing utilities through construction as approved by the utility owner and the Engineer at the Contractor's expense.

## Sheet Index

C100	Title Sheet
C101	ERU Plan
C102	Site Survey
C200	Site Plan
C201	Demolition Plan
C300	Grading Plan
C301	Entrance & Parking Grading Plan
C302	Grading & Paving Details
C400	Paving & Pavement Marking Plan
C401	Jointing Plan
C500	Fencing Plan
SWS100	SWS Plan & Profile
SWS101	Precast Manhole Details
SWS102	Storm Sewer Details
SWS103	Single-Double Drop Inlet Details
EC100	Erosion Control Plan
EC101-105	Erosion Control Details

Date: 2022-03-24  
 Inspector: A. Thompson  
 Design/Inspecting Firm: Kaw Valley Engineering, Inc.  
 Contractor: Subcontractor: Apex Excavating LLC

Note: Please refer to Merestone asbuilts, sheet 18 and asbuilt points in separate file.

## Benchmark

Benchmark #1 - Square Cut on the Top of Concrete Light Base located South of the South Entrance of Quik Trip or 75' E & 271' S of the Centerlines of Central & Greenwich

Elevation = 1381.39 NAVD88

Benchmark #2 - Square Cut on the Top of Curb located in the East Curb of Greenwich Rd or 55' S of the South Property Line & 38' N of an Existing FH

Elevation = 1386.63 NAVD88

# STORM SEWER, PAVING, & GRADING to serve part of SLAWSON EAST, INC. CONDOMINIUM STORAGE

## 286 N Greenwich Rd. City of Wichita, Kansas

Gary Janzen, P.E. City Engineer  
 Project Number 704 PPD (133119)

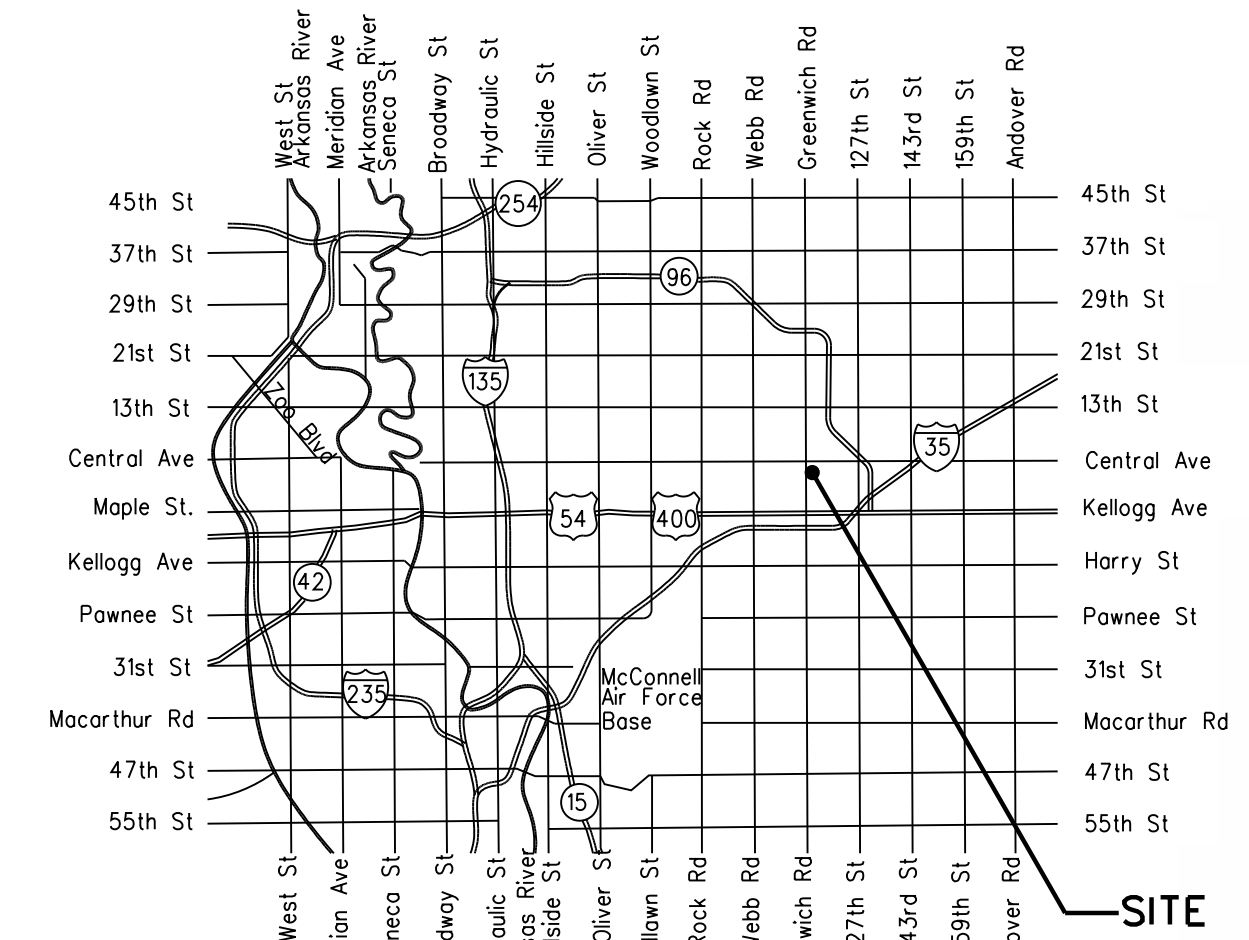
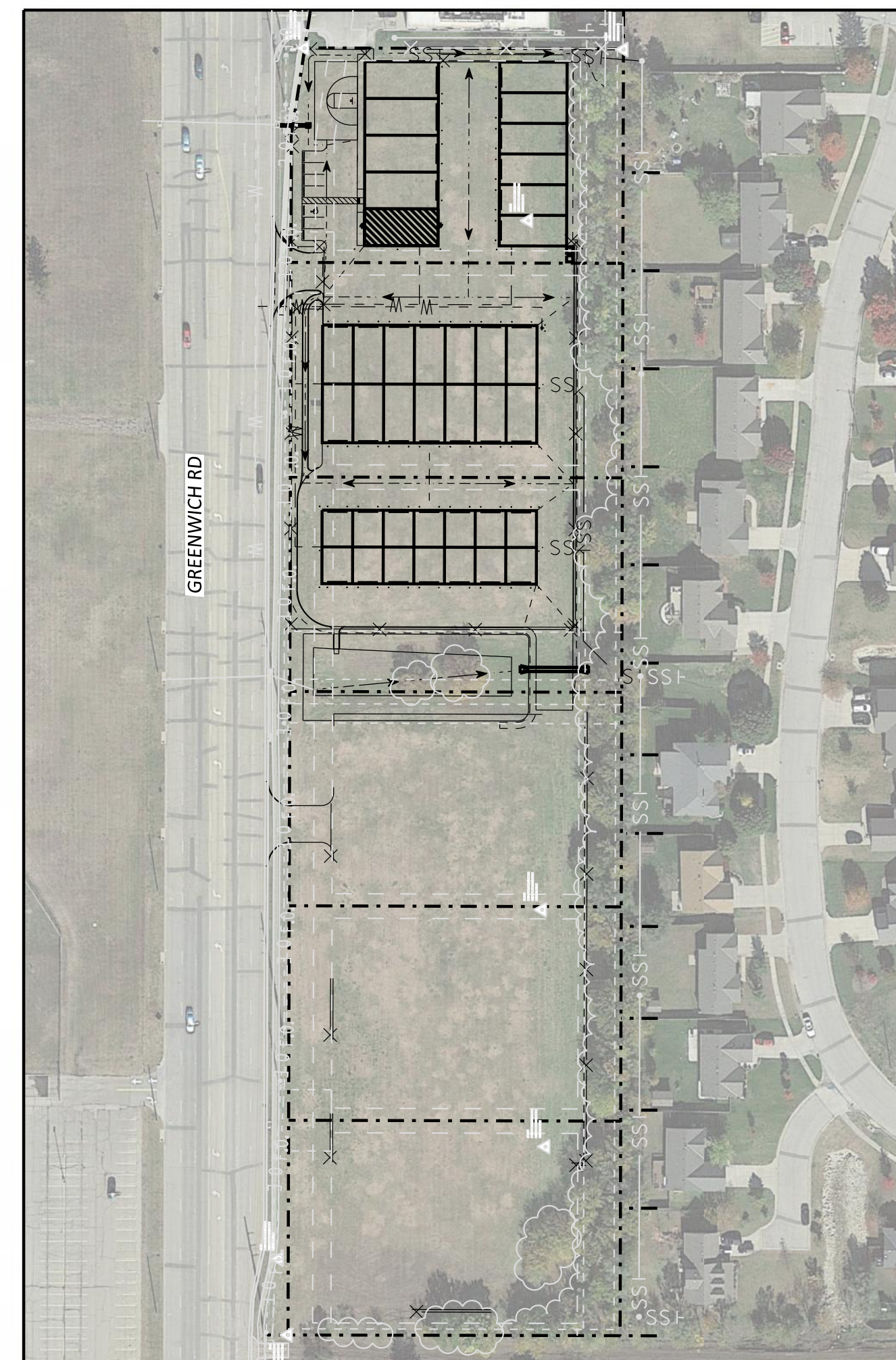

Vicinity Map

### Stormwater Certification

(New Development) or Redevelopment (Circle One)

Stormwater Permit #: SWO2021-0025

NOI Permit #: S-AR94-1703 KSR116657

These construction plans were prepared in accordance with the current Stormwater Management Regulations as set forth in the City of Wichita's Stormwater Management Ordinance 16.32 and the policies/guidelines presented in the Wichita/Sedgewick County Stormwater Manual.

Site Area (Acres) = 4.35  
 Disturbed Area (Acres) = 2.28  
 Water Quality Treatment: Offsite BMP Program  
 Downstream Channel Protection: N/A  
 Detention: Dry Detention Pond - See Drainage Calculation Report  
 The BMP used for this development is Off Site BMP Program

APPROVED AS NOTED  
 BY WICHITA PUBLIC WORKS  
 ENGINEERING DIVISION

Engineering Benjamin Ferguson, 8-4-2021

Utilities Joe Hickle, 8-4-2021

### NOTE TO CONTRACTORS

Inspection and testing for this project is to be provided by a Licensed Consulting Engineering Firm under contract with the Owner/Developer. Said inspection to be in accordance with the City of Wichita standard construction engineering practices and certified by a Licensed Professional Engineer in the state of Kansas. No work shall be performed by the Contractor without such inspection nor shall any work be commenced without written authorization by City Engineering. All Construction and Materials shall comply with the current City of Wichita Specifications and Standards and Special Provisions. (on file and available at Wichita.gov)

An approved copy of these plans signed by City staff are required on-site.



Issue	Date	By	Description
0	8-4-2021	KLH	ISSUE FOR CONSTRUCTION
-	-	-	-
-	-	-	-
-	-	-	-

Drawn By: BNH  
 Checked By: KLH  
 Date: 8-4-2021  
 Issue No. 0



Client: SLAWSON EAST, INC. 727 N. WACO, SUITE 400 WICHITA, KS 67203

CONDOMINIUM STORAGE  
 TITLE SHEET  
 WICHITA, KANSAS

Sheet No. C100  
 Project No. 2534

AUGUST 2021



# Boundary Survey

Lots 2, 3, 4, 5, 6 and 7, Block 1  
Canyon Properties Addition to Wichita,  
Sedgwick County, Kansas

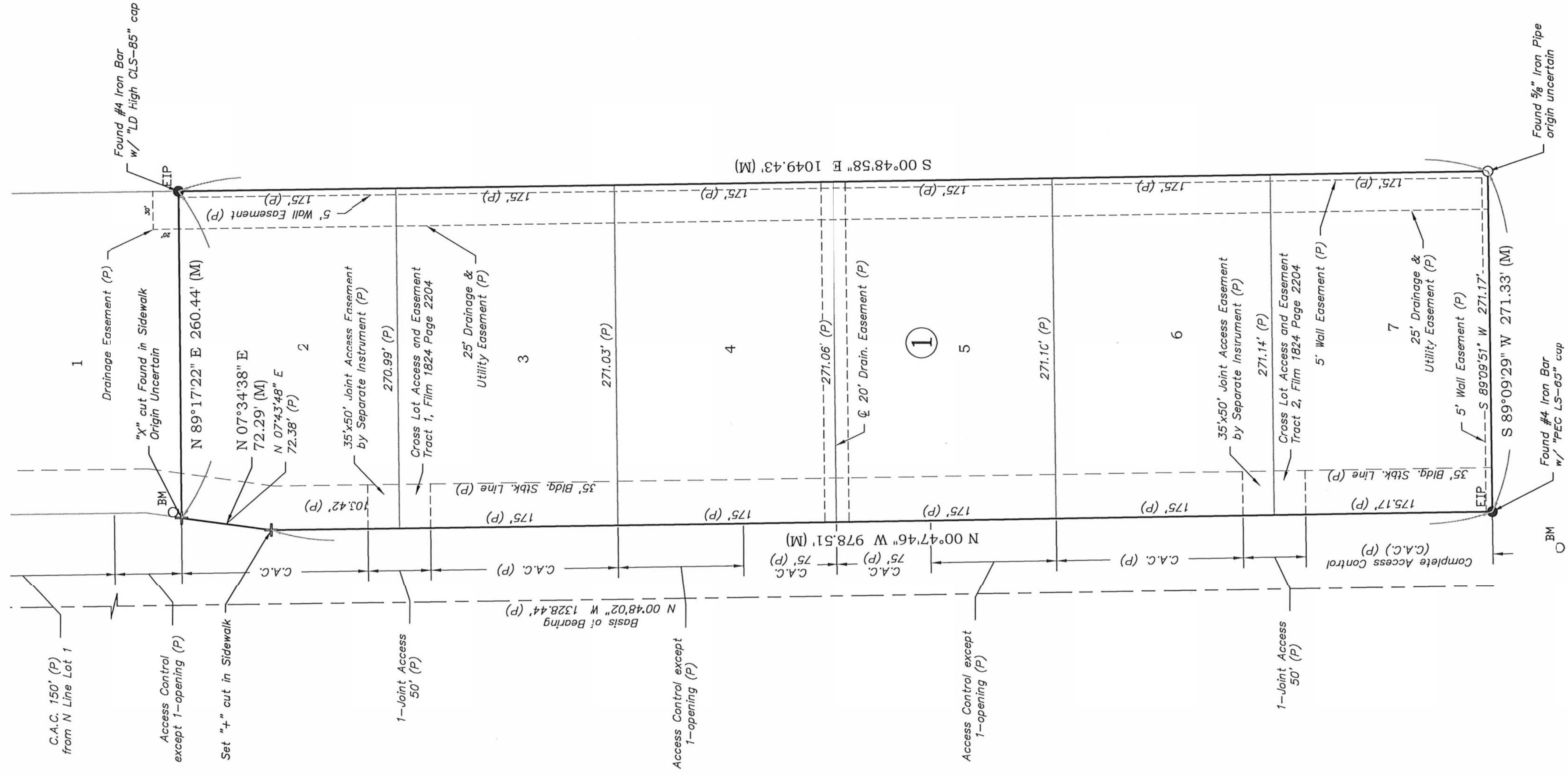

**LEGEND**

- IPS = Set 1/2" Iron Bar w/Cap
- "Merestone CLS 179"
- Existing Iron Bar w/ Cap
- Existing Iron Pipe
- + = "+ " Cut in Concrete
- = Site Benchmark
- (M) = Measured Bearing/Distance
- (CP) = Calc'd from Plat
- (P) = Per Plat

- = Property Line
- - - = Centerline Road
- = Lot Line
- - - = Easement Line
- - - = Building Setback Line

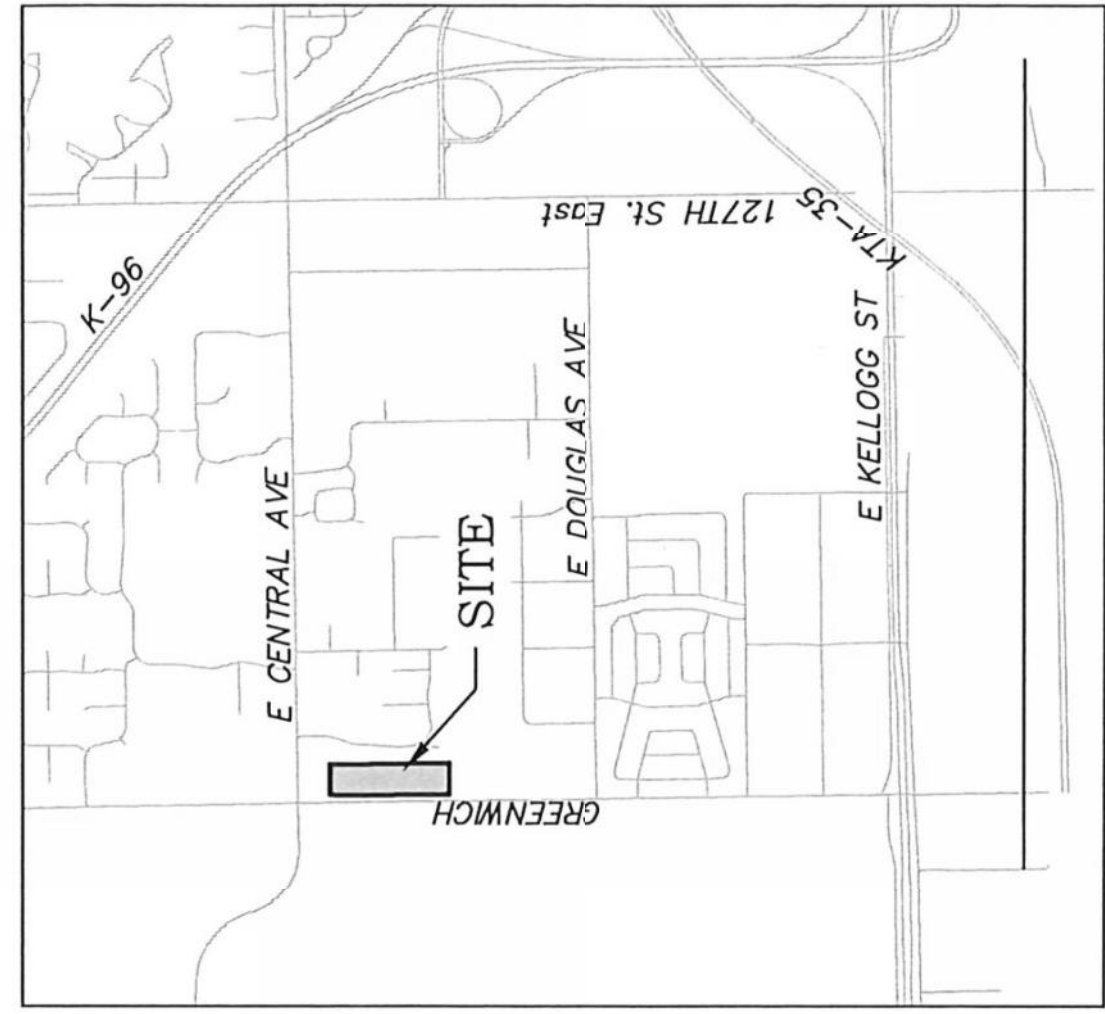
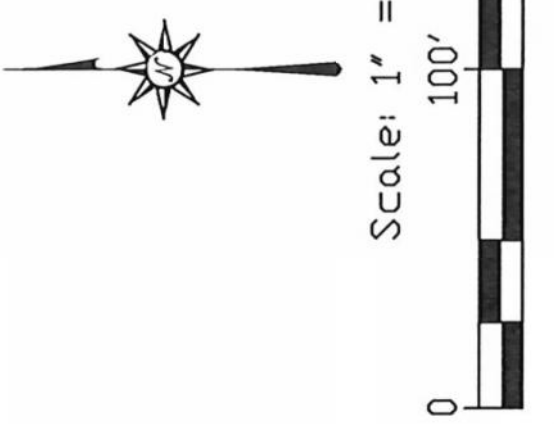

State of Kansas )  
June 18, 2021 ) SS  
County of Sedgwick

We, Merestone Surveying LLC, Surveyors in  
aforesaid county and state do hereby certify that  
this 18th day of June, performed a boundary  
survey of the following:

**LOTS 2, 3, 4, 5, 6 and 7, BLOCK 1, CANYON  
PROPERTIES ADDITION TO WICHITA,  
SEDGWICK COUNTY, KANSAS.**

The accompanying sketch is a true and correct  
exhibit of said survey based on actual field  
measurements where the monuments are of the  
character and occupy the positions as indicated.



Brian L. Peltier, PS #1517

**Boundary Survey Notes:**

- Bearings are based on the Centerline/Section line of Greenwich Rd being platted/measured as N 00°48'02" W. Error of Closure is better than 1:20,000
- Field Work was completed on June 18, 2021.
- Title work was provided by client.
- Details from Community Unit Plan (DP-229) recorded on Film 1824 Page 2203 were not shown hereon.
- Interior lot monuments were not set per client request.

**Benchmarks:**

BM #1 = Square Cut on the Top of a Concrete Light Base located South of the South Entrance of QuikTrip or 75' East and 271' South of the Centerlines of Central and Greenwich.  
Elevation = 1381.39 (NAVD88)

BM #2 = Square Cut on the Top of Curb located in the East Curb of Greenwich Rd, 55' South of the South Property Line and 38' North of an Existing FH.  
Elevation = 1386.63 (NAVD88)

**Merestone Surveying**

Boundary Survey  
Canyon Properties Addition  
ASM Engineering  
221 E. Commerce St.  
Andover, KS 67002  
(316) 260-5895

PROJECT NUMBER 2104-143	SURVEYED TH	DRAWN TH
REVISIONS	APPROVED BP	DATE 6/18/21
	SCALE As Noted	SHEET 1 OF 1

K:\CAD\Design\Survey\0\_ASM\2104-143\Canyon Properties Topo\DWG\2104-143\_Canyon Properties Boundary.dwg

Issue	Date	By	Description
0	8-4-2021	KLH	ISSUE FOR CONSTRUCTION
-	-	-	-
-	-	-	-
-	-	-	-
-	-	-	-

Drawn By: BNH  
Checked By: KLH

Date: 8/4/2021  
Issue No. 0



SEE SURVEY



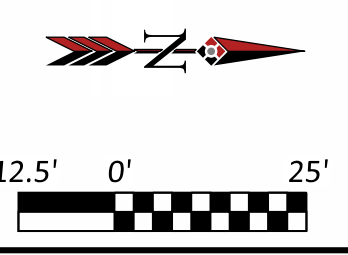

Issue	Date	By	Description
0	8-4-2021	KLH	ISSUE FOR CONSTRUCTION
-	-	-	-
-	-	-	-
-	-	-	-

Drawn By: BNH  
 Checked By: KLH  
 Date: 8/4/2021  
 Issue No. 0



Client: **SLAWSON EAST, INC.**  
 727 N. WACO, SUITE 400  
 WICHITA, KS 67203

CONDOMINIUM STORAGE  
**DEMOLITION PLAN**  
 WICHITA, KANSAS

Sheet No. **C201**  
 Project No. **2534**

PLANNET Design 2021, Conwood Properties, LLC, Wichita, KS 67203, 2021, Conwood Properties, LLC



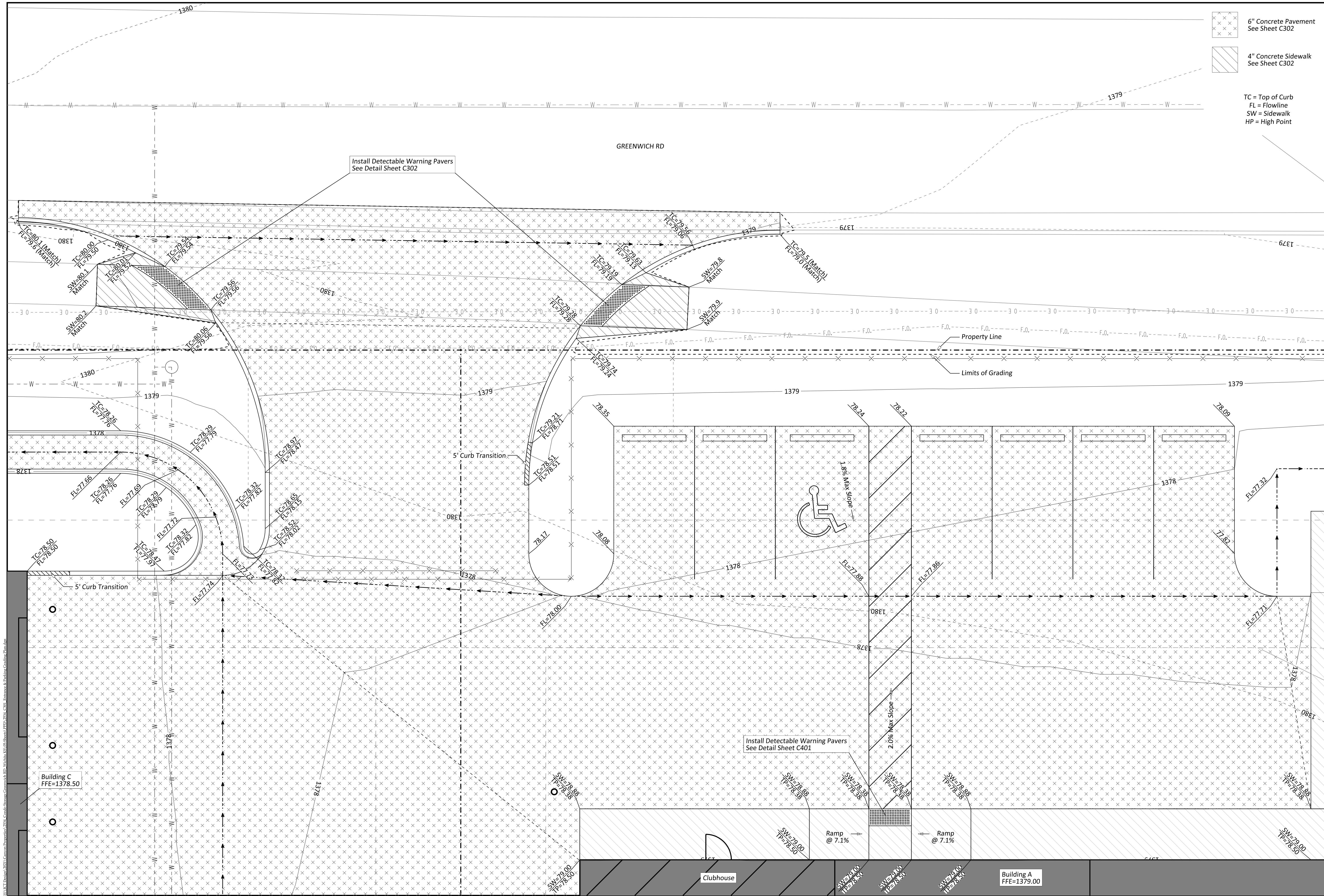

6" Concrete Pavement  
See Sheet C302

4" Concrete Sidewalk  
See Sheet C302

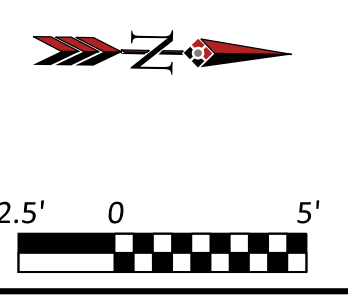

TC = Top of Curb  
FL = Flowline  
SW = Sidewalk  
HP = High Point



Issue	Date	By	Description
0	8-4-2021	KLH	ISSUE FOR CONSTRUCTION

Drawn By: BNH  
Checked By: KLH  
Date: 8/4/2021  
Issue No. 0



Client:  
**SLAWSON EAST, INC.**  
727 N. WACO, SUITE 400  
WICHITA, KS 67203

CONDOMINIUM STORAGE  
**ENTRANCE & PARKING GRADING PLAN**  
WICHITA, KANSAS

Sheet No.  
**C301**

Project No.  
**2534**

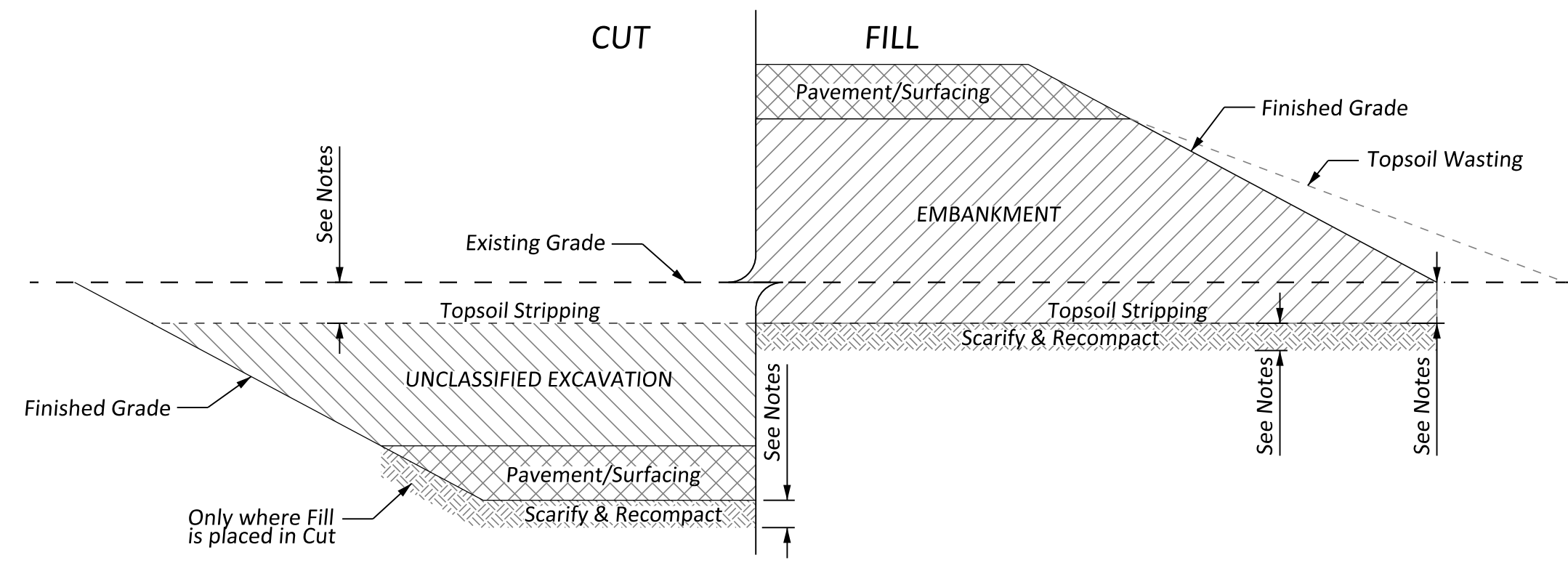

**CUT-FILL DIAGRAM**

**EARTHWORK NOTES**

- Strip 4" topsoil in all areas of disturbance. No topsoil shall be incorporated into engineered fill. All topsoil shall be wasted on-site as top 4" lift of all non-pavement areas. The wasted material shall be compacted & graded to drain. This work shall be SUBSIDIARY to "Topsoil Stripping".
- Areas in cut not receiving pavement shall be over excavated to a depth of 4" and replaced with topsoil.
- Once the topsoil is stripped, the top 9" of exposed subgrade shall be proof-rolled, scarified, and recompact to 95% Std. Proctor (ASTM D-698) then brought to grade with fill material.
- Proof-rolling of the subgrade prior to fill placement provides a more stable base for placement of fill and aids in identifying soft or disturbed areas. Unsuitable areas identified by the proof-rolling operation should be undercut and replaced with engineered fill. Proof-rolling can be accomplished through the use of a fully-loaded tandem-axle dump truck or similar equipment providing equivalent subgrade loading.
- Place fill in loose lifts (8" thick or less) to design grade. Lift thickness shall be reduced to 6" in confined areas. Compact each lift to 95% Standard Proctor density (ASTM D-698). Cohesive soils shall be compacted with a sheep's foot roller, while sand and gravel material shall be compacted with a vibratory roller.
- Moisture content of new fill shall be controlled to within ±3% of optimum for silts, clayey sand, and LVC and shall be controlled to within +4% for fat clay and lean clay. Drying may be achieved by spreading borrow material out to air-dry in maximum 12" thick layers.
- Each lift of fill material shall be tested by a geotechnical engineering company licensed in the State of Kansas.
- Contractor is responsible for protecting areas to be filled from freezing/frost. All fill material to be placed shall be free of frost or any frozen material.
- Reference the Terracon Geotechnical Engineering Report No. 01205191 dated November 2020 for complete testing & compaction requirements.

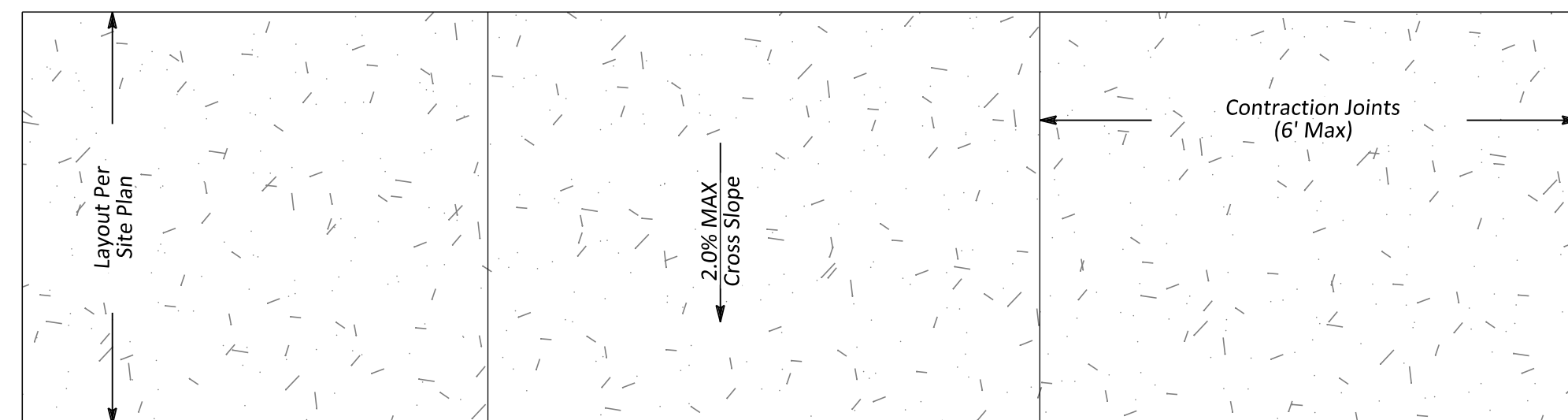

**TYPICAL 4" CONCRETE SIDEWALK**

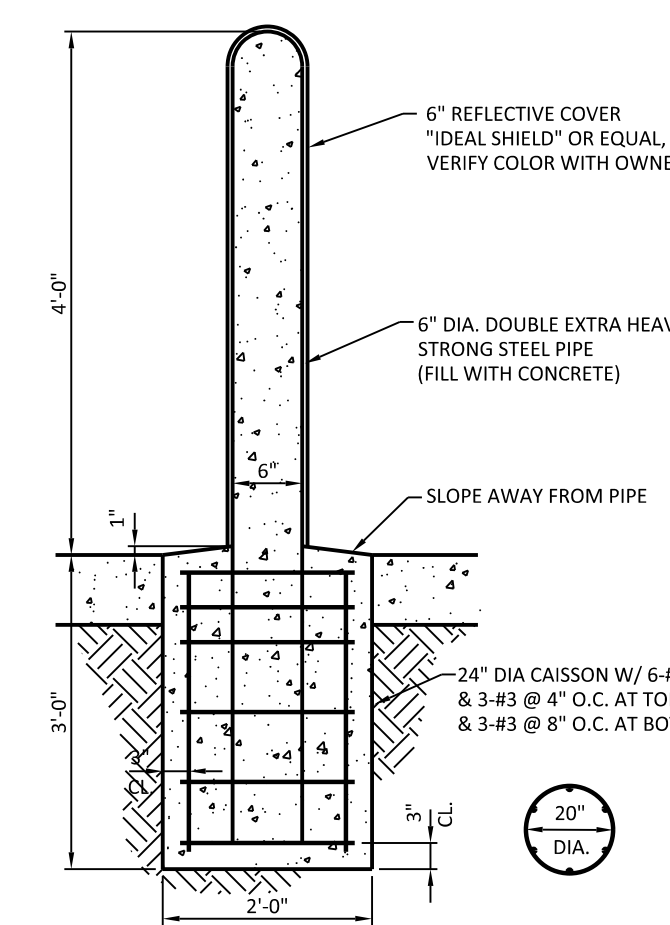

**TYPICAL 5'-0" BOLLARD**

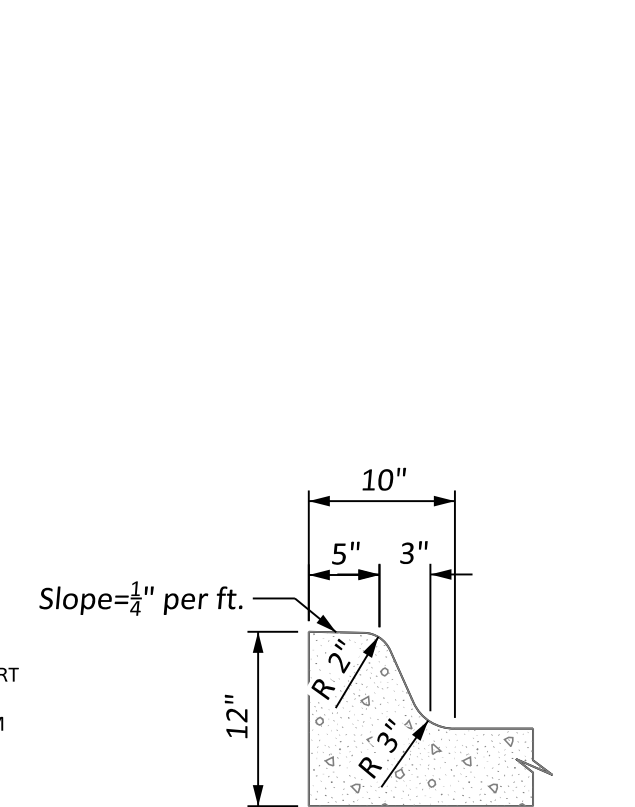

**6" MONOLITHIC CURB**

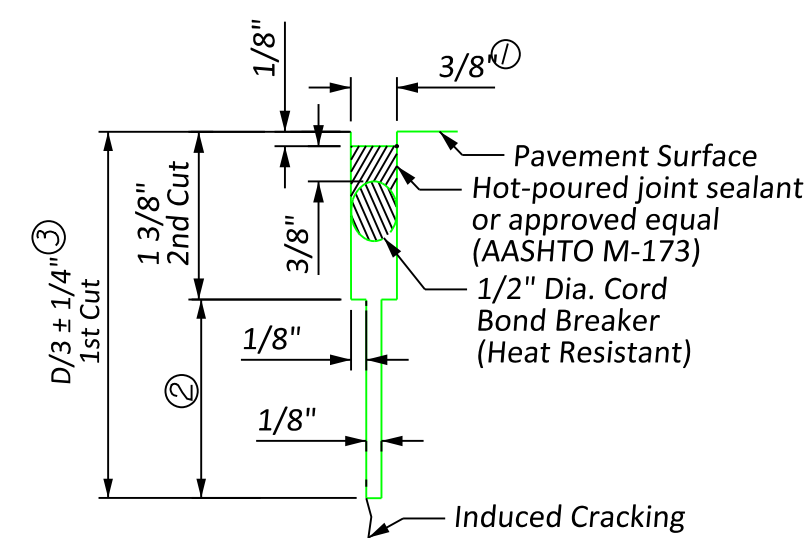

**DETAIL A**

- To be accomplished in 2 cuts for Longitudinal Joints and Contraction Joints.
- Eliminate bottom of cut when metal keyway is used as part of Longitudinal or Transverse Construction Joint and at Doweled Construction Joint Locations.
- 1 3/8" Minimum

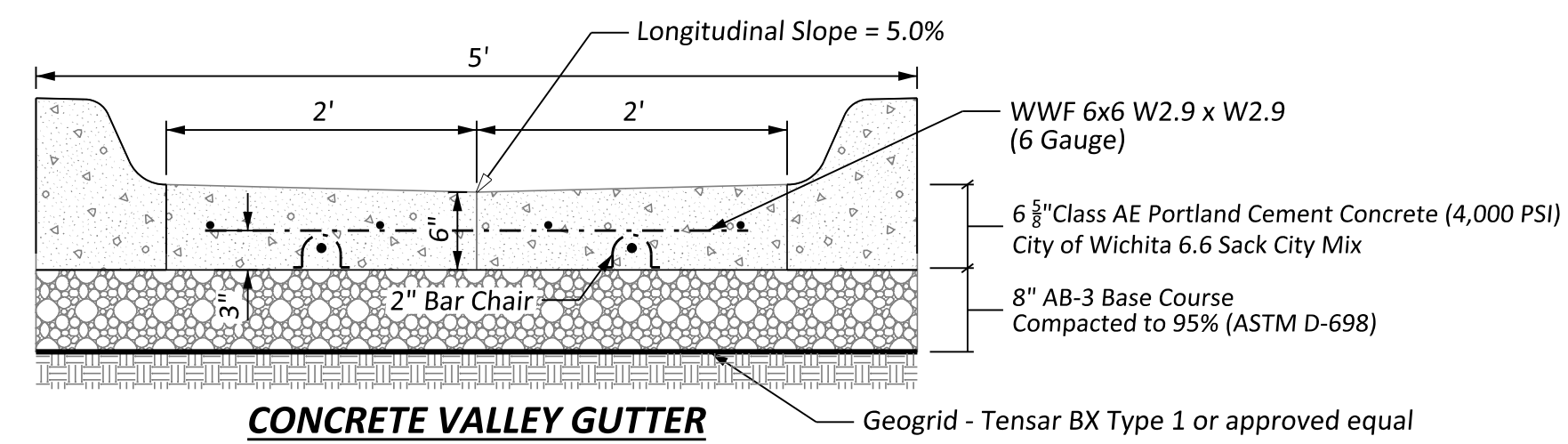

**CONCRETE VALLEY GUTTER**

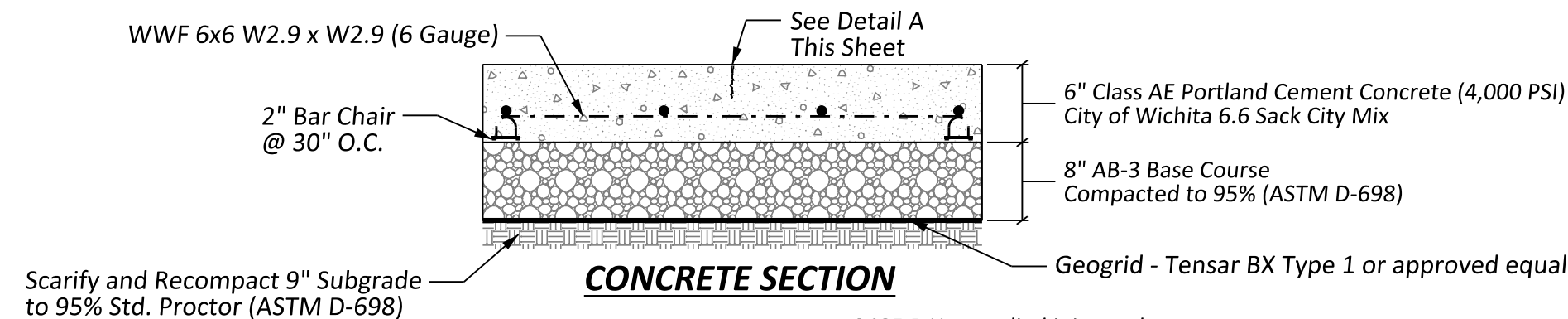

**CONCRETE SECTION**

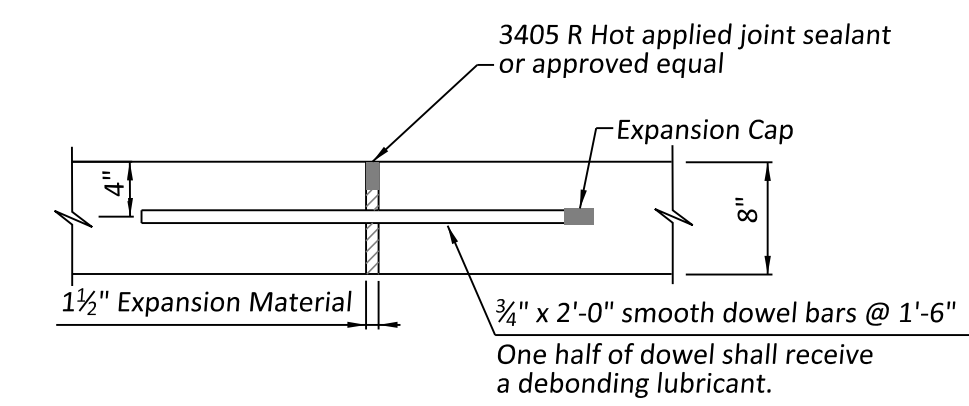

**DOWELED EXPANSION JOINT**

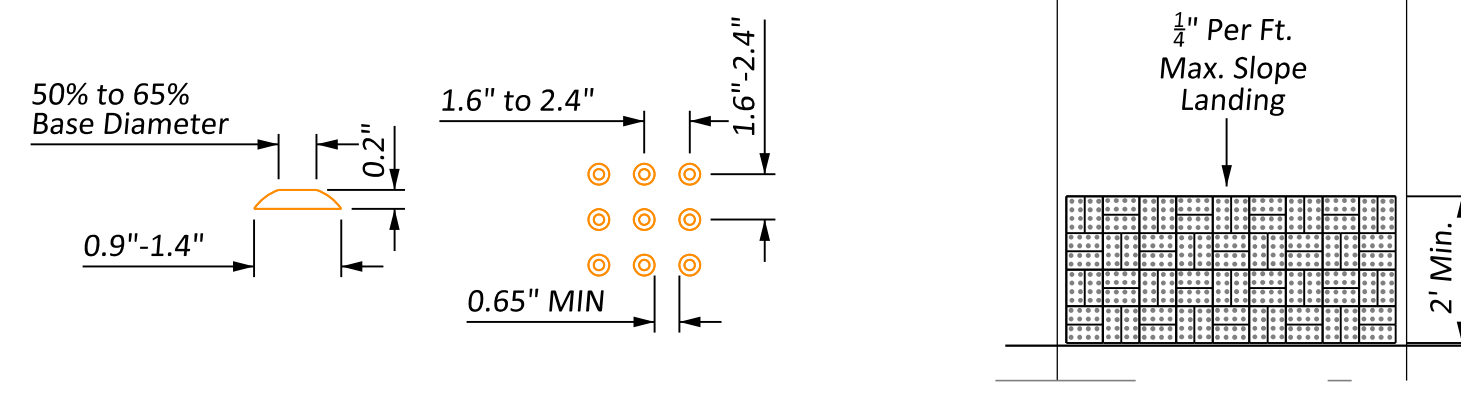

**DOME DETAIL**

NOTE: Stamped colored concrete ramps to comply with the latest ADAAG guidelines. Pavestone detectable warning pavers (or an approved equal) shall be used in all wheelchair ramps. The Red stamped concrete shall be installed using a basket weave/parquet pattern. Other patterns may be used with approval of engineer. Align domes in the direction of pedestrian travel.

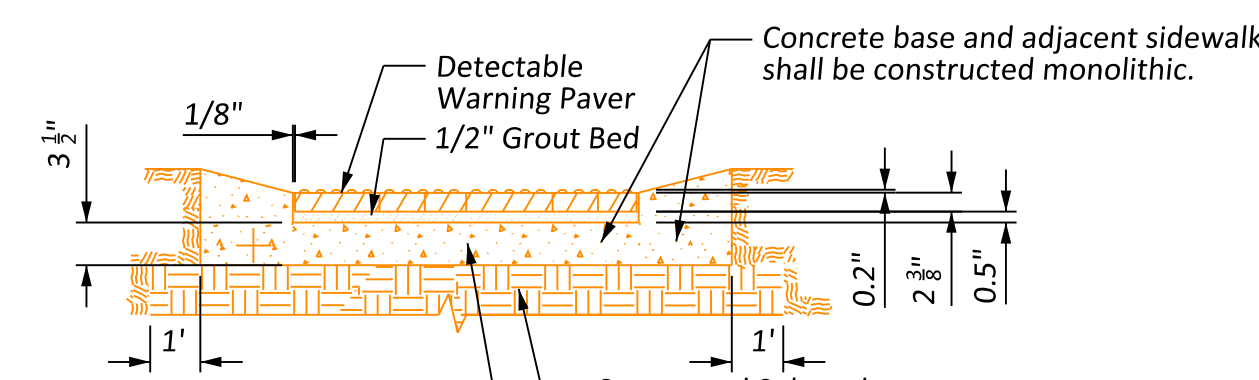

**SECTION B-B**

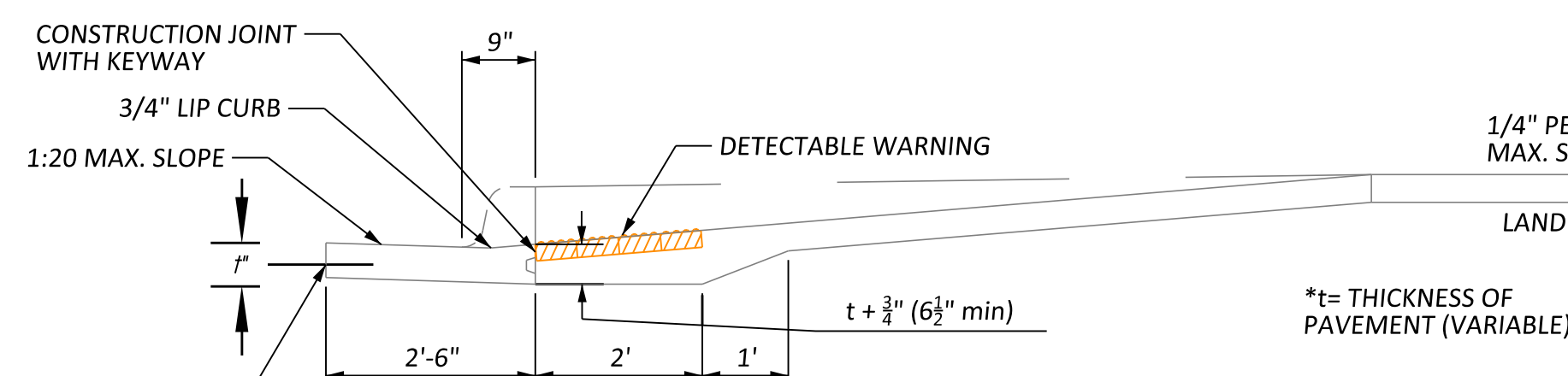

**SECTION A-A**

DOWEL & GROUT #4 x 18" LONG BARS 24" O.C. AS NECESSARY

**CONCRETE DESIGN**

- Concrete shall have a minimum 28-day compressive strength of 4000 psi (5.5% air entrained). Concrete mix design shall meet City of Wichita portland cement concrete specifications Section 406.
- A minimum of 3 cylinders shall be obtained from each pour, for testing. Cylinders shall be prepared by an engineer approved inspector.
- A slump test shall be performed for each pour by an engineer approved inspector, maximum allowable slump shall be 3".
- A air content test shall be performed for each pour by an engineer approved inspector, minimum allowable air content shall be 4%, max air content shall be 8%.

**BASE ROCK**

- Base rock shall be crushed rock or broken stone (or a mixture of these materials) composed of clean, hard, durable and uncoated particles.
- Dolomitic Limestone shall have a calcium carbonate to magnesium carbonate ratio of 4:3.
- Base rock shall not contain shale, clay lumps, or other deleterious substances in a quantity exceeding 2.5% (by weight) of the amount retained on the No. 4 sieve.
- Base rock shall be free of dust, soft or flaky particles, loams, alkali, organic matter, paper, wood, or other deleterious material.
- The Los Angeles Abrasion loss percentage shall not exceed 45, as measured by ASTM C131.
- Base rock shall not have a loss greater than 14% after 16 freeze-thaw cycles.
- Base rock shall not have an absorption greater than 5% by weight.
- Base rock shall meet the gradation shown in Table 2.

TABLE 2 - BASE ROCK GRADATION (% Passing By Weight)

Sieve Size	2"	1-1/2"	3/4"	No. 4	No. 8	No. 40	No. 200
AB-3	100	100-95	95-70	65-40	55-30	40-16	20-8

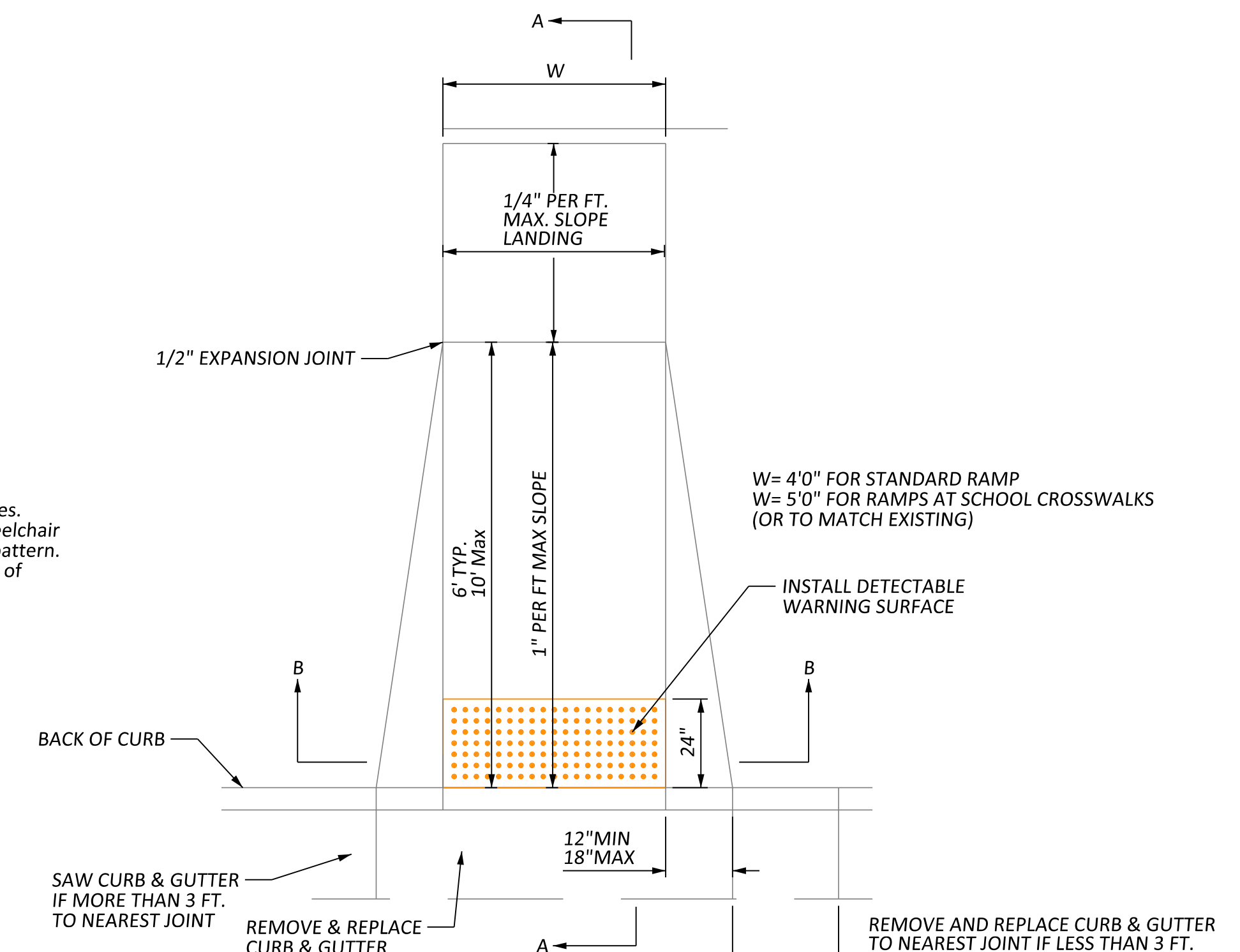

**(TYPE A) STANDARD WHEELCHAIR RAMP DETAIL FOR STREETS WITH COMBINED CURB & GUTTER**

**TYPICAL SECTION DETECTABLE WARNING PAVER**

NOTE: RAMPS TO COMPLY WITH LATEST ADAAG GUIDELINES. HANOVER DETECTABLE WARNING PAVERS (OR AN APPROVED EQUAL) SHALL BE USED IN ALL WHEELCHAIR RAMPS. THE RED PAVER SHALL BE INSTALLED USING A BASKET WEAVE/PARQUET PATTERN. OTHER PATTERNS MAY BE USED WITH APPROVAL OF ENGINEER. SAND FILL JOINTS. ALIGN DOMES IN THE DIRECTION OF PEDESTRIAN TRAVEL.

**DETECTABLE WARNING PAVERS**



Issue	Date	By	Description
0	8-4-2021	KLH	ISSUE FOR CONSTRUCTION

Drawn By: BNH  
Checked By: KLH  
Date: 8/4/2021  
Issue No. 0



Client: **SLAWSON EAST, INC.**  
727 N. WACO, SUITE 400  
WICHITA, KS 67203

CONDOMINIUM STORAGE  
**GRADING & PAVING DETAILS**  
WICHITA, KANSAS

Sheet No. **C302**  
Project No. **2534**



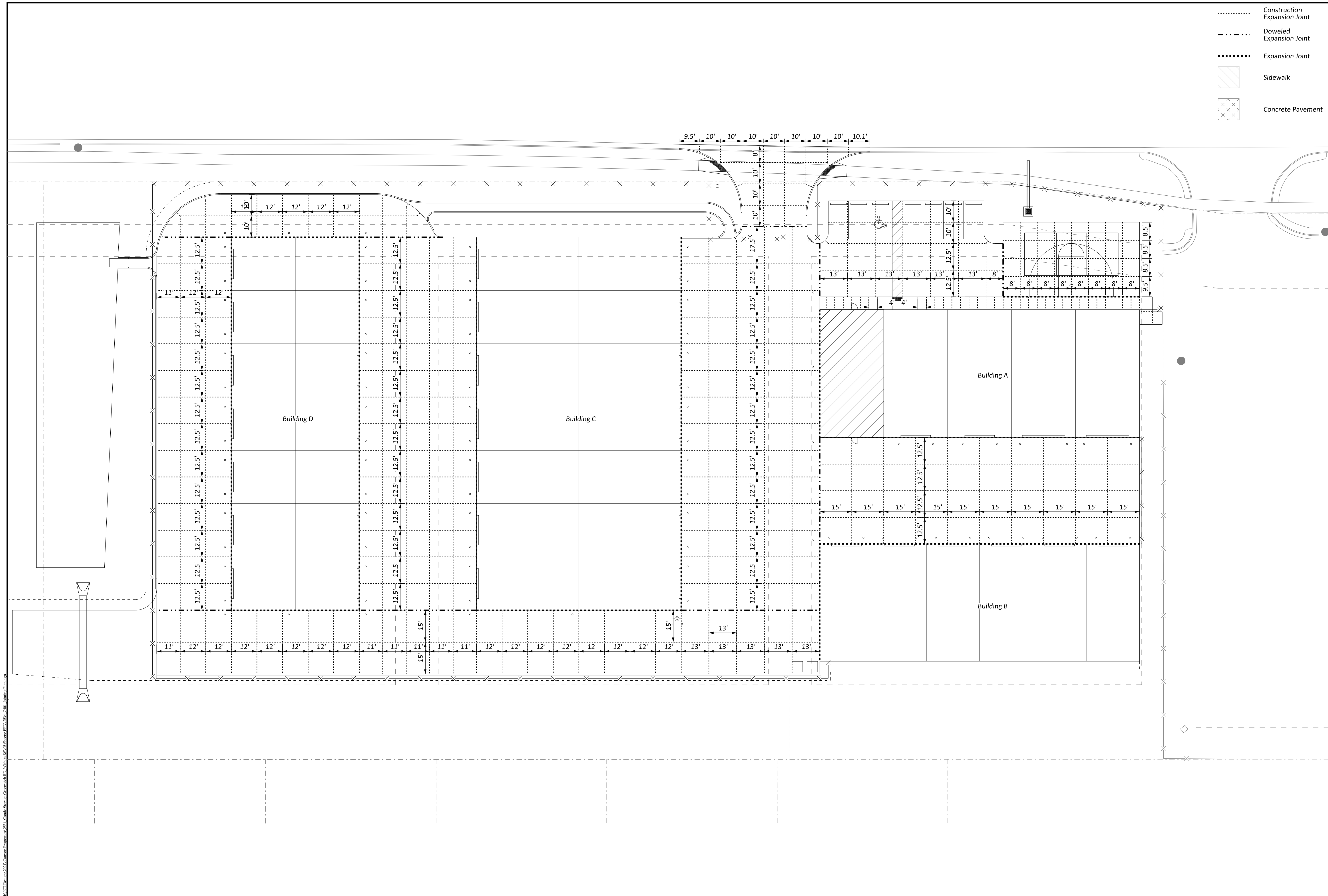

PLANNET Desktop 2011, Command: Drawings\2534\_Condomium Storage\Drawings\2534\_Condomium Storage\Jointing Plan.dwg, 8/4/2021 10:48:11 AM, User: kls

- ..... Construction Expansion Joint
- - - - - Doweled Expansion Joint
- · - · - Expansion Joint
- ▨ Sidewalk
- ⊗ Concrete Pavement

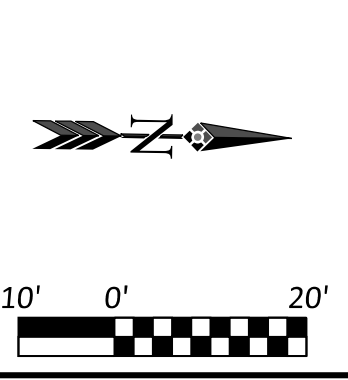

Issue	Date	By	Description
0	8-4-2021	KLH	ISSUE FOR CONSTRUCTION
-	-	-	-
-	-	-	-
-	-	-	-

Drawn By: BNH  
 Checked By: KLH  
 Date: 8/4/2021  
 Issue No. 0



**Client:**  
**SLAWSON EAST, INC.**  
 727 N. WACO, SUITE 400  
 WICHITA, KS 67203

**CONDOMINIUM STORAGE**  
**JOINTING PLAN**  
 WICHITA, KANSAS

Sheet No.  
**C401**  
 Project No.  
**2534**





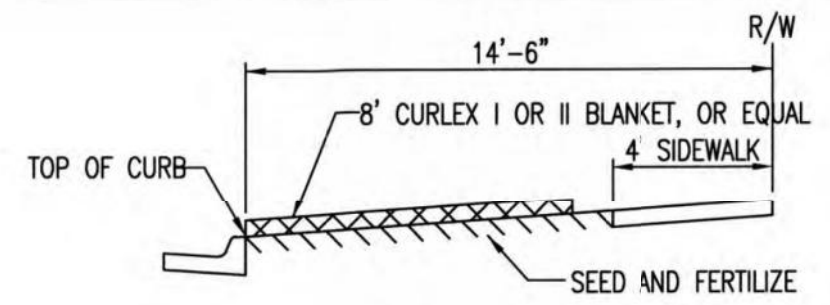

SECTION B-B

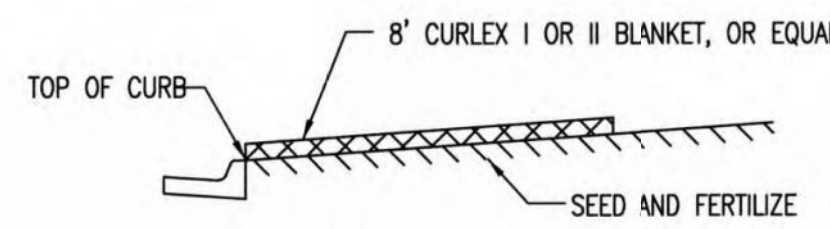

SECTION A-A

INSTALL 8' WIDE CURLEX I OR II EXCELSIOR BLANKET, OR EQUAL, ON PREPARED SURFACE BACK OF CURB. EDGE OF BLANKET WILL BE AT BACK OF CURB. INSTALL PER MANUFACTURERS RECOMMENDATION, INCLUDING STAPLES. (SEE DETAIL)

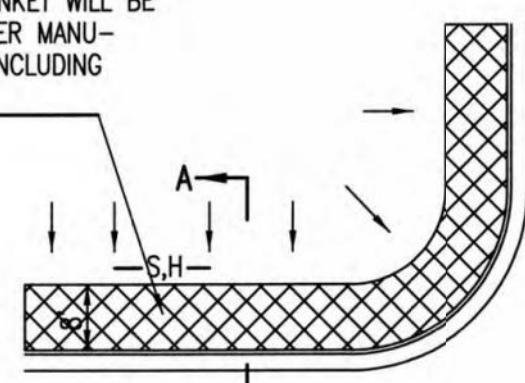

SOUTH STREET

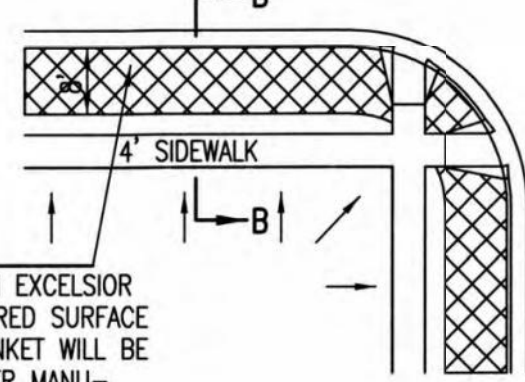

INSTALL 8' WIDE CURLEX I OR II EXCELSIOR BLANKET, OR EQUAL, ON PREPARED SURFACE BACK OF CURB. EDGE OF BLANKET WILL BE AT BACK OF CURB. INSTALL PER MANUFACTURERS RECOMMENDATION, INCLUDING STAPLES. (SEE DETAIL)

GENERAL NOTES

- EXCELSIOR MAT TO BE INSTALLED WHEN SOD IS NOT SPECIFIED ON PROJECT.
- EXCELSIOR BLANKET TO BE INSTALLED OVER SEED AND FERTILIZER, AS SPECIFIED IN THE PROJECT SPECIFICATIONS.
- AFTER INSTALLATION OF EXCELSIOR BLANKET, AT LOCATIONS WHERE CONCENTRATED FLOW CARRIES SEDIMENT OVER THE CURB AND INTO THE GUTTER, SUPPLEMENTAL EROSION CONTROL DEVICES WILL BE INSTALLED BY THE CONTRACTOR AS NEEDED, TO FIX THE PROBLEM.

BACK OF CURB PROTECTION DETAIL

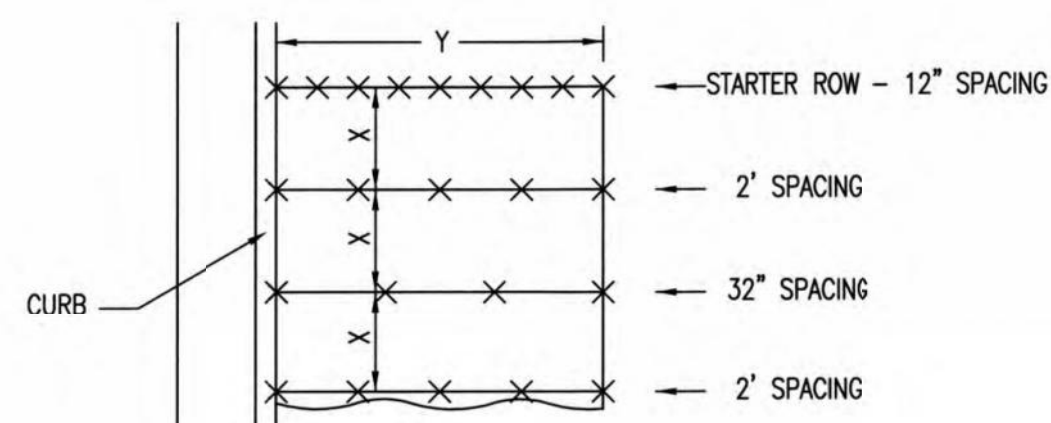

NOTES: USE 6" SEAM OVERLAP (X & Y = RECOMMENDED BY MANUFACTURE)

DETAILS FOR APPROVED EROSION CONTROL MAT

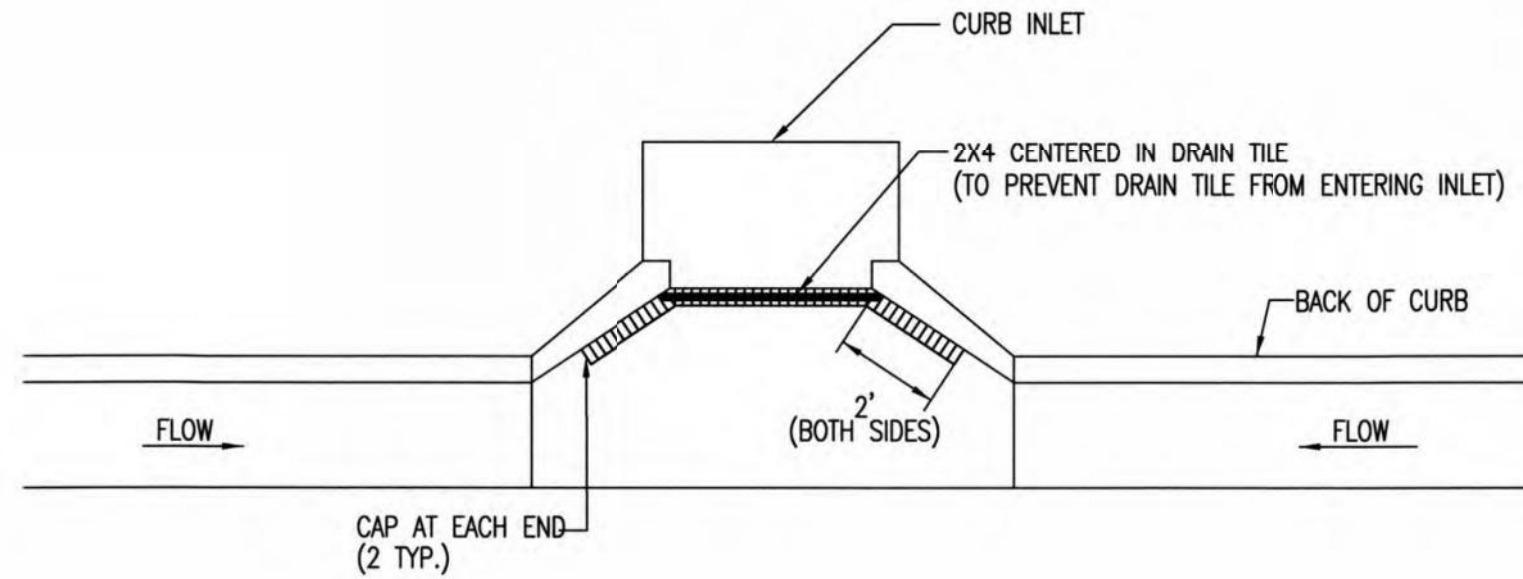

NOTE: PLACE 4" PERFORATED PVC PIPE, FILLED WITH 1/2"-1" DIA. GRAVEL, IN FRONT OF CURB INLET AS SHOWN.

2X4 LENGTH	INLET TYPE	INLET OPENING
5'-6"	1-A	5'-0"
10'-6"	1-A	10'-0"
15'-6"	1-A	15'-0"

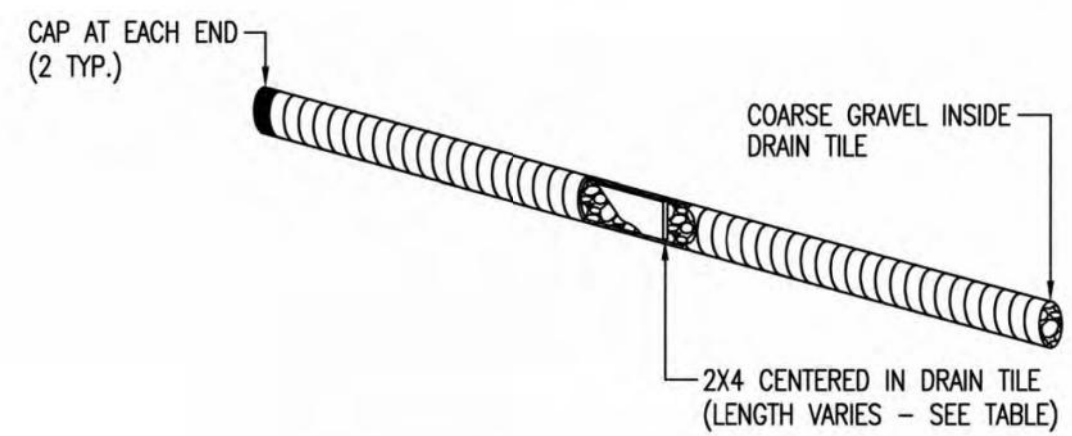

CURB INLET PROTECTION  
4" PERFORATED PIPE W/ GRAVEL

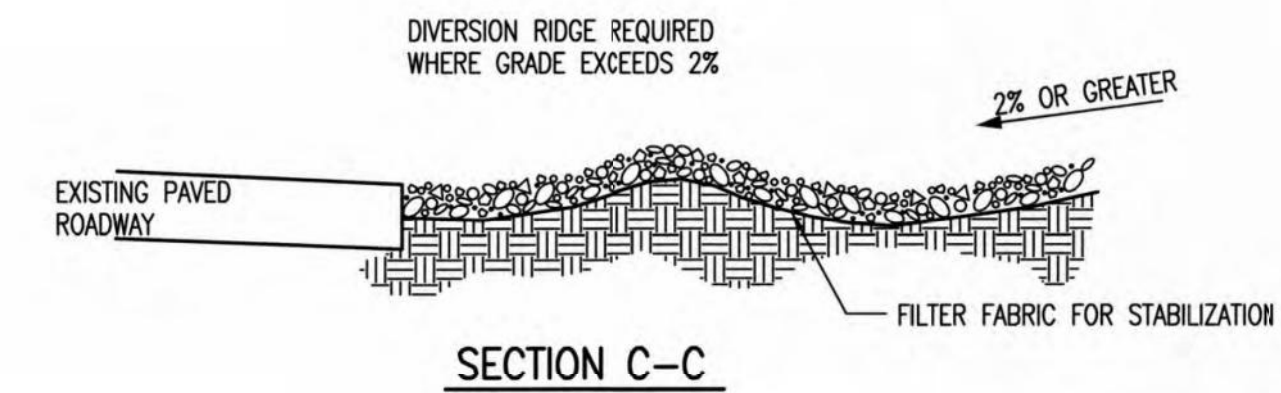

SECTION C-C

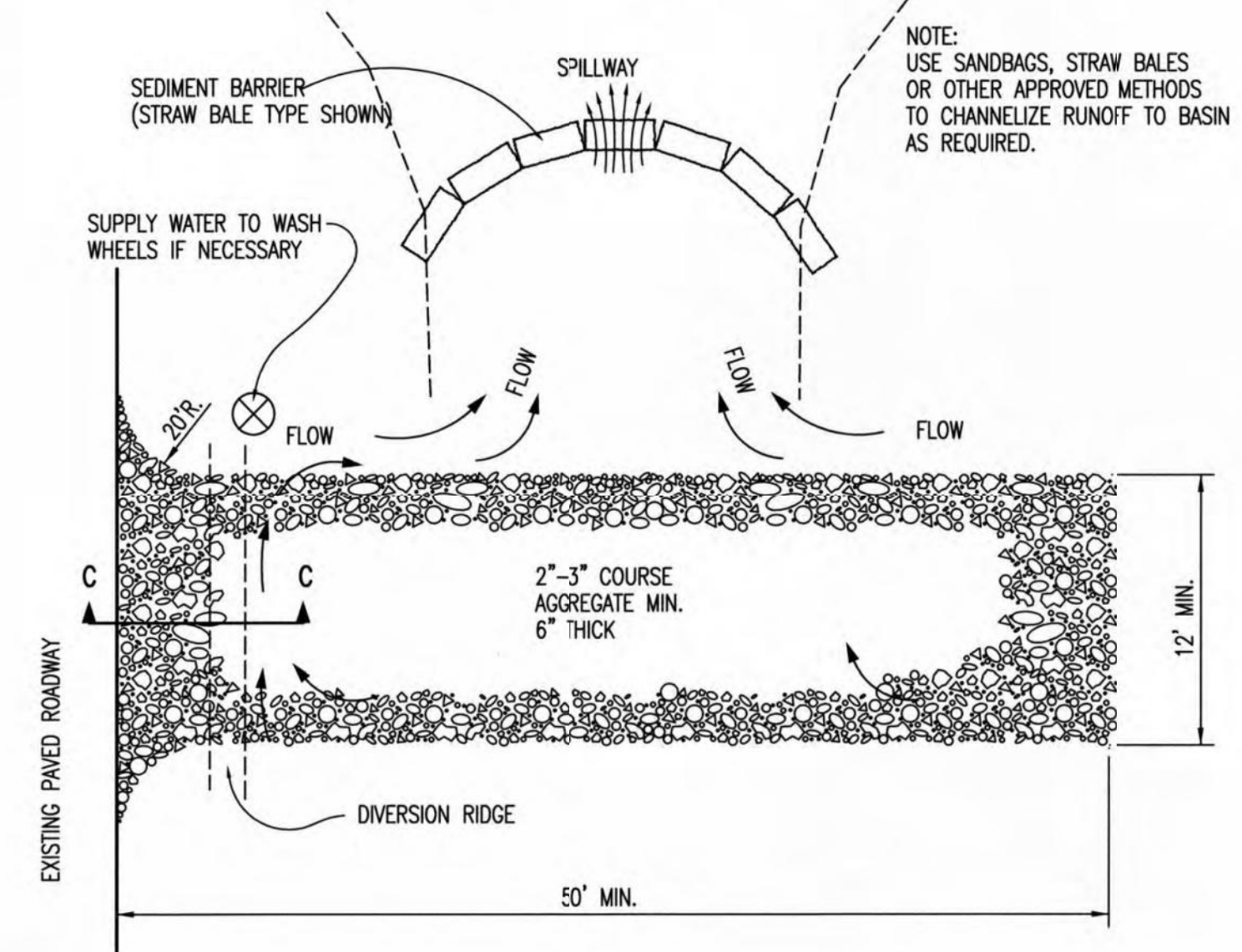

STABILIZED CONSTRUCTION ENTRANCE

GENERAL NOTES

- THE ENTRANCE SHALL BE MAINTAINED IN A CONDITION THAT WILL PREVENT TRACKING OR FLOWING OF SEDIMENT ONTO PUBLIC RIGHTS-OF-WAY. THIS MAY REQUIRE TOP DRESSING, REPAIR AND/OR CLEANOUT OF ANY MEASURES USED TO TRAP SEDIMENT.
- WHEN NECESSARY, WHEELS SHALL BE CLEANED PRIOR TO ENTRANCE ONTO PUBLIC RIGHT-OF-WAY.
- WHEN WASHING IS REQUIRED, IT SHALL BE DONE ON AN AREA STABILIZED WITH CRUSHED STONE THAT DRAINS INTO AN APPROVED SEDIMENT TRAP OR SEDIMENT BASIN, AS SHOWN ABOVE.
- DRIVE ENTRANCES ONTO RESIDENTIAL LOTS WILL NOT BE REQUIRED TO HAVE THE SEDIMENT BARRIER SHOWN, BUT WHEEL WASHING MAY BE REQUIRED IF STABILIZED ENTRANCE IS NOT SUFFICIENT TO KEEP MUD FROM BEING TRACKED ONTO ADJACENT STREET. ENTRANCE SHALL EXTEND FROM BACK OF CURB TO DWELING.



REVISION DATE: MAY 2013

**BACK OF CURB PROTECTION, CURB INLET PROTECTION AND CONSTRUCTION ENTRANCE**

CITY ENGINEER  
**GARY JANZEN, P.E.**

PROJECT NUMBER 2534	OCA NUMBER	DATE
CITY ENGINEER'S OFFICE CITY HALL - SEVENTH FLOOR 455 NORTH MAIN STREET WICHITA, KANSAS 67202-1620 (316) 268-4501		SHEET EC101



Issue	Date	By	Description
0	8-4-2021	KLH	ISSUE FOR CONSTRUCTION

Drawn By: BNH  
Checked By: KLH  
Date: 8/4/2021  
Issue No. 0



Client:  
**SLAWSON EAST, INC.**  
727 N. WACO, SUITE 400  
WICHITA, KS 67203

CONDOMINIUM STORAGE  
**EROSION CONTROL DETAILS**  
WICHITA, KANSAS

Sheet No.  
**EC101**  
Project No.  
**2534**

PLACKET Design 2021, Copyright Reserved. All Rights Reserved. Wichita, KS 67202. Wichita, KS 67202. Wichita, KS 67202. Wichita, KS 67202. Wichita, KS 67202.



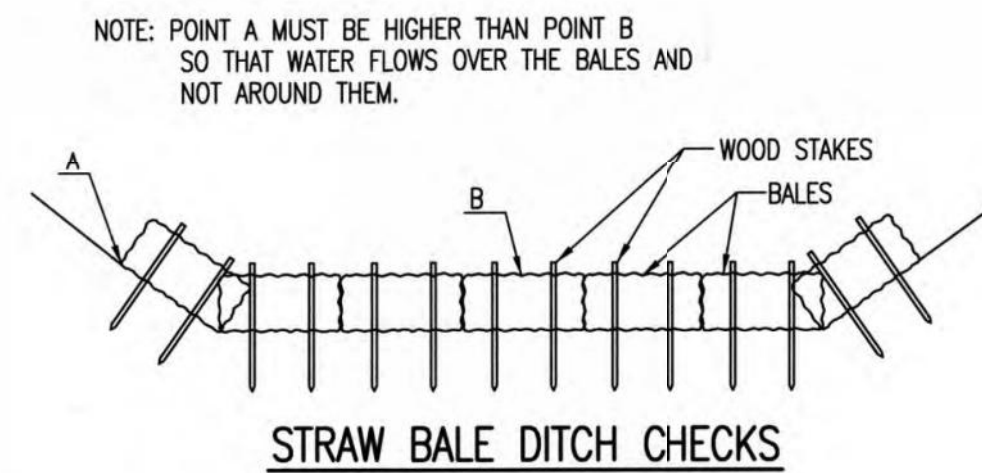

**MATERIAL SPECIFICATION:**

BALE DITCH CHECKS MAY BE CONSTRUCTED OF WHEAT STRAW, OAT STRAW, PRAIRIE HAY, OR BROMEGRASS HAY THAT IS FREE OF WEEDS DECLARED NOXIOUS BY THE KANSAS STATE BOARD OF AGRICULTURE. THE STAKES USED TO ANCHOR THE BALES SHOULD BE A HARDWOOD MATERIAL WITH THE FOLLOWING MINIMUM DIMENSIONS: 2" SQUARE (NOMINAL) BY 4' LONG. OPTIONAL: THE DOWNSTREAM SCOUR APRON SHOULD BE CONSTRUCTED OF A DOUBLE-NETTED STRAW EROSION-CONTROL BLANKET AT LEAST 6' WIDE. OPTIONAL: THE METAL LANDSCAPE STAPLES USED TO ANCHOR THE EROSION-CONTROL BLANKET SHOULD BE AT LEAST 8" LONG.

**PLACEMENT:**

BALE DITCH CHECKS SHOULD BE PLACED PERPENDICULAR TO THE FLOWLINE OF THE DITCH. THE DITCH CHECK SHOULD EXTEND FAR ENOUGH SO THAT THE GROUND LEVEL AT THE ENDS OF THE CHECK IS HIGHER THAN THE TOP OF THE LOWEST CENTER BALE. THIS PREVENTS WATER FROM FLOWING AROUND THE CHECK. STRAW BALE DITCH CHECKS SHOULD NOT BE PLACED IN DITCHES WHERE HIGH FLOWS ARE EXPECTED. ROCK CHECKS SHOULD BE USED INSTEAD. BALES SHOULD BE PLACED IN DITCHES WITH SLOPES OF 6% OR LESS. FOR SLOPES STEEPER THAN 6%, ROCK CHECKS SHOULD BE USED. THE FOLLOWING TABLE PROVIDES CHECK SPACING FOR A GIVEN DITCH GRADE:

DITCH GRADE (%)	CHECK SPACING (FEET)
0.5	200
1.0	200
2.0	100
3.0	65
4.0	50
5.0	40
6.0	30

**PROPER INSTALLATION METHOD:**

EXCAVATE A TRENCH PERPENDICULAR TO THE DITCH FLOWLINE THAT IS 4" DEEP AND A BALE'S WIDTH WIDE. EXTEND THE TRENCH IN A STRAIGHT LINE ALONG THE ENTIRE LENGTH OF THE PROPOSED DITCH CHECK. PLACE THE SOIL ON THE UPSTREAM SIDE OF THE TRENCH-IT WILL BE USED LATER. OPTIONAL: ON THE DOWNSTREAM SIDE OF THE TRENCH, ROLL OUT A LENGTH OF EROSION-CONTROL BLANKET (SCOUR APRON) EQUAL TO THE LENGTH OF THE TRENCH. PLACE THE UPSTREAM EDGE OF THE EROSION-CONTROL BLANKET ALONG THE BOTTOM UPSTREAM EDGE OF THE TRENCH. THE EROSION CONTROL BLANKET SHOULD BE ANCHORED IN THE TRENCH WITH ONE ROW OF 8" LANDSCAPE STAPLES PLACED ON 18" CENTERS. THE REMAINDER OF THE EROSION-CONTROL BLANKET (THE PORTION THAT IS NOT LYING IN THE TRENCH) WILL SERVE AS THE DOWNSTREAM SCOUR APRON. THIS SECTION OF THE BLANKET SHOULD BE ANCHORED TO THE GROUND WITH 8" LANDSCAPE STAPLES PLACED AROUND THE PERIMETER OF THE BLANKET ON 18" CENTERS. THE REMAINDER OF THE BLANKET SHOULD BE ANCHORED USING TWO EVENLY SPACED ROWS OF 8" LANDSCAPE STAPLES ON 18" CENTERS PLACED PERPENDICULAR TO THE FLOWLINE OF THE DITCH. PLACE THE BALES IN THE TRENCH, MAKING SURE THAT THEY ARE BUTTED TIGHTLY. TWO STAKES SHOULD BE DRIVEN THROUGH EACH BALE ALONG THE CENTERLINE OF THE DITCH CHECK, APPROXIMATELY 6" TO 8" IN FROM THE BALE ENDS. STAKES SHOULD BE DRIVEN AT LEAST 12" INTO THE GROUND. ONCE ALL THE BALES HAVE BEEN INSTALLED AND ANCHORED, PLACE THE EXCAVATED SOIL AGAINST THE UPSTREAM SIDE OF THE CHECK AND COMPACT IT. THE COMPACTED SOIL SHOULD BE NO MORE THAN 3" TO 4" DEEP AND EXTEND UPSTREAM NO MORE THAN 24".

**LIST OF COMMON PLACEMENT/INSTALLATION MISTAKES TO AVOID:**

DO NOT PLACE A BALE DITCH CHECK DIRECTLY IN FRONT OF A CULVERT OUTLET. IT WILL NOT STAND UP TO THE CONCENTRATED FLOW.  
DO NOT PLACE BALE DITCH CHECKS IN DITCHES THAT WILL LIKELY EXPERIENCE HIGH FLOWS. THEY WILL NOT STAND UP TO CONCENTRATED FLOW.  
FOLLOW PRESCRIBED DITCH-CHECK SPACING GUIDELINES. IF SPACING GUIDELINES ARE EXCEEDED, EROSION WILL OCCUR BETWEEN THE DITCH CHECKS.  
DO NOT ALLOW WATER TO FLOW AROUND THE DITCH CHECK. MAKE SURE THAT THE DITCH CHECK IS LONG ENOUGH SO THAT THE GROUND LEVEL AT THE ENDS OF THE CHECK IS HIGHER THAN THE TOP OF THE LOWEST CENTER BALE.  
DO NOT PLACE BALE DITCH CHECKS IN CHANNELS WITH SHALLOW SOILS UNDERLAIN BY ROCK. IF THE CHECK IS NOT ANCHORED SUFFICIENTLY, IT WILL WASH OUT.  
BALE DITCH CHECKS MUST BE DUG INTO THE GROUND. BALES AT GROUND LEVEL DO NOT WORK BECAUSE THEY ALLOW WATER TO FLOW UNDER THE CHECK.

**INSPECTION AND MAINTENANCE:**

BALE DITCH CHECKS SHOULD BE INSPECTED EVERY 7 DAYS AND WITHIN 24 HOURS OF A RAINFALL OF 1/2" OR MORE. THE FOLLOWING IS A LIST OF QUESTIONS THAT SHOULD BE ADDRESSED DURING EACH INSPECTION:  
DOES WATER FLOW AROUND THE DITCH CHECK?  
DOES WATER FLOW UNDER THE DITCH CHECK?  
DOES WATER FLOW THROUGH SPACES BETWEEN ABUTTING BALES?  
ARE ANY BALES AND/OR SCOUR APRONS (OPTIONAL) DISLODGED?  
ARE BALES DECOMPOSING DUE TO AGE AND/OR WATER DAMAGE?  
DOES SEDIMENT NEED TO BE REMOVED FROM BEHIND THE DITCH CHECK?

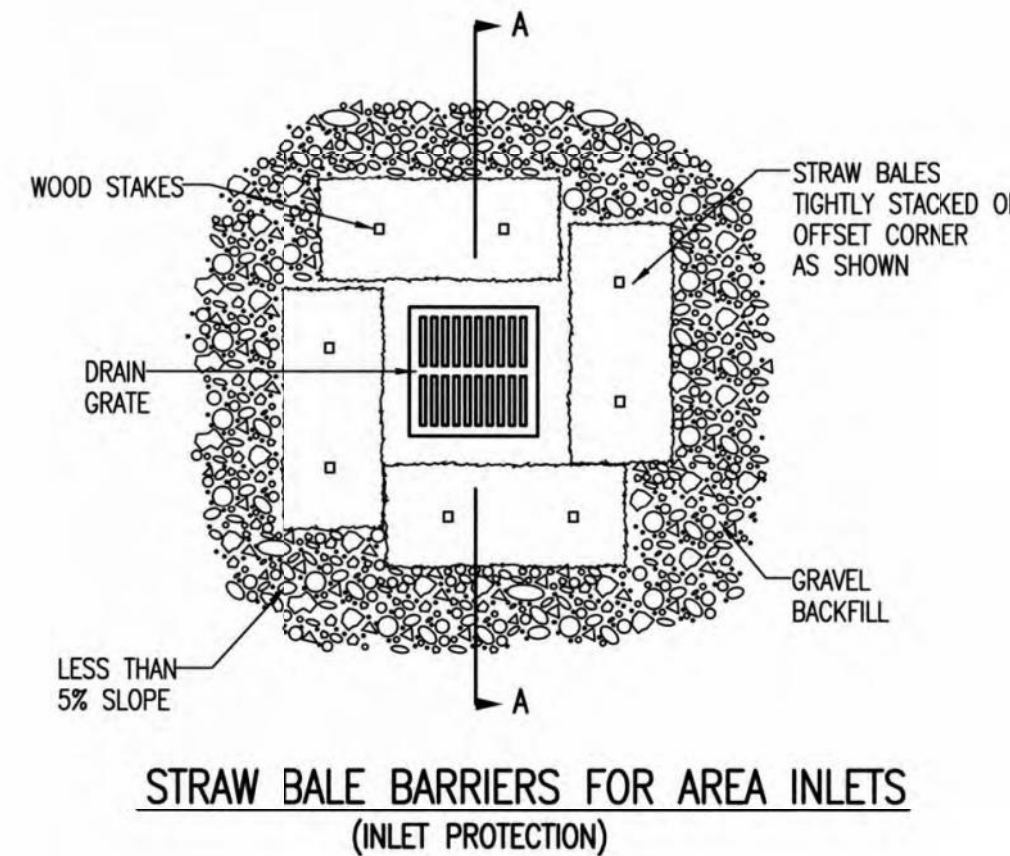
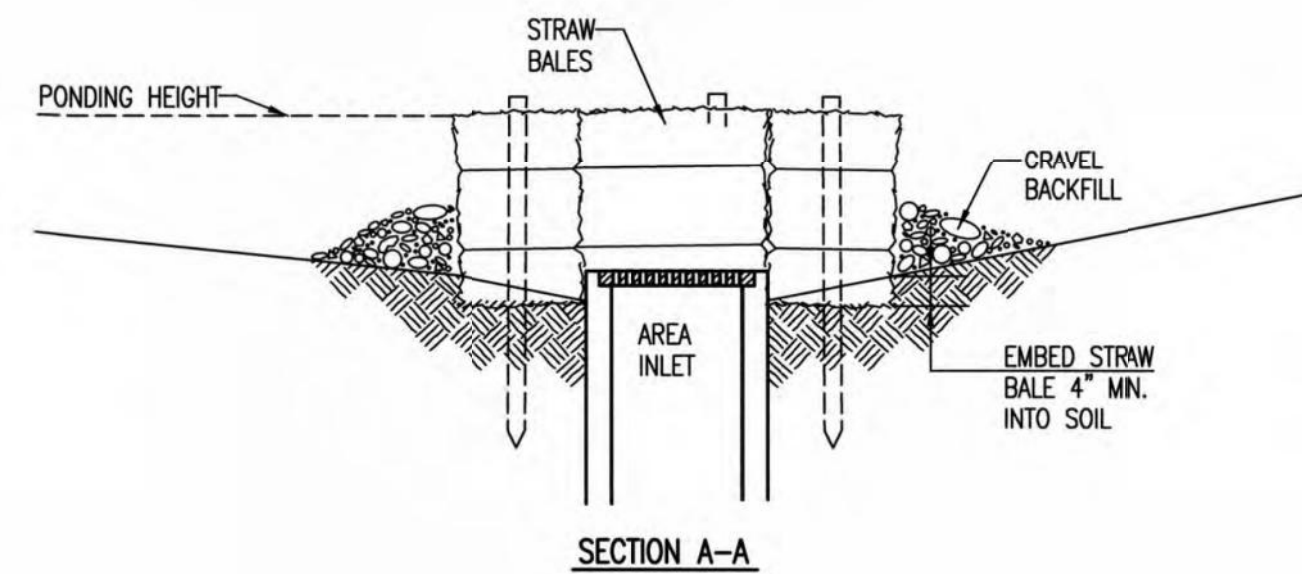

**MATERIAL SPECIFICATION:**

BALE AREA INLET BARRIERS SHOULD BE CONSTRUCTED OF WHEAT STRAW, OAT STRAW, PRAIRIE HAY, OR BROMEGRASS HAY THAT IS FREE OF WEEDS DECLARED NOXIOUS BY THE KANSAS STATE BOARD OF AGRICULTURE. THE STAKES USED TO ANCHOR THE BALES SHOULD BE A HARDWOOD MATERIAL WITH THE FOLLOWING MINIMUM DIMENSIONS: 2" SQUARE (NOMINAL) BY 4' LONG. TWINE SHOULD BE USED TO BIND BALES. THE USE OF WIRE BINDING IS PROHIBITED BECAUSE IT DOES NOT BIODEGRADE READILY.

**PLACEMENT:**

BALE AREA INLET BARRIERS SHOULD BE PLACED DIRECTLY AROUND THE PERIMETER OF A DROP INLET. WHEN A BALE AREA INLET BARRIER IS LOCATED NEAR AN INLET THAT HAS STEEP APPROACH SLOPES, THE STORAGE CAPACITY BEHIND THE BARRIER IS DRAMATICALLY REDUCED. TIMELY REMOVAL OF SEDIMENT MUST OCCUR FOR A BARRIER TO OPERATE PROPERLY IN THIS LOCATION.

**PROPER INSTALLATION METHOD:**

EXCAVATE A TRENCH AROUND THE PERIMETER OF THE AREA INLET THAT IS AT LEAST 4" DEEP BY A BALE'S WIDTH WIDE. PLACE THE BALES IN THE TRENCH, MAKING SURE THAT THEY ARE BUTTED TIGHTLY. SOME BALES MAY NEED TO BE SHORTENED TO FIT INTO THE TRENCH AROUND THE AREA INLET. TWO STAKES SHOULD BE DRIVEN THROUGH EACH BALE, APPROXIMATELY 6" TO 8" IN FROM THE BALE ENDS. STAKES SHOULD BE DRIVEN AT LEAST 12" INTO THE GROUND. ONCE ALL THE BALES HAVE BEEN INSTALLED AND ANCHORED, PLACE THE EXCAVATED SOIL AGAINST THE RECEIVING SIDE OF THE BARRIER AND COMPACT IT. THE COMPACTED SOIL SHOULD BE NO MORE THAN 3" TO 4" DEEP. NOTE: WHEN A BALE AREA INLET BARRIER IS PLACED IN A SHALLOW MEDIAN DITCH, MAKE SURE THAT THE TOP OF THE BARRIER IS NOT HIGHER THAN THE PAVED ROAD. IN THIS CONFIGURATION, WATER MAY SPREAD ONTO THE ROADWAY CAUSING A HAZARDOUS CONDITION.

**LIST OF COMMON PLACEMENT/INSTALLATION MISTAKES TO AVOID:**

BALES SHOULD BE PLACED DIRECTLY AGAINST THE PERIMETER OF THE AREA INLET. THIS ALLOWS OVERTOPPING WATER TO FLOW DIRECTLY INTO THE INLET INSTEAD OF ONTO NEARBY SOIL CAUSING SCOUR. BALE AREA INLET BARRIERS MUST BE DUG INTO THE GROUND. BALES AT GROUND LEVEL DO NOT WORK BECAUSE THEY ALLOW WATER TO FLOW UNDER THE BARRIER.

**INSPECTION AND MAINTENANCE:**

BALE AREA INLET BARRIERS SHOULD BE INSPECTED EVERY 7 DAYS AND WITHIN 24 HOURS OF A RAINFALL OF 1/2" OR MORE. THE FOLLOWING IS A LIST OF QUESTIONS THAT SHOULD BE ADDRESSED DURING EACH INSPECTION:  
DOES WATER FLOW UNDER THE AREA INLET BARRIER?  
DOES WATER FLOW THROUGH SPACES BETWEEN ABUTTING BALES?  
ARE ANY BALES DISLODGED?  
ARE BALES DECOMPOSING DUE TO AGE AND/OR WATER DAMAGE?  
DOES SEDIMENT NEED TO BE REMOVED FROM BEHIND THE AREA INLET BARRIER?

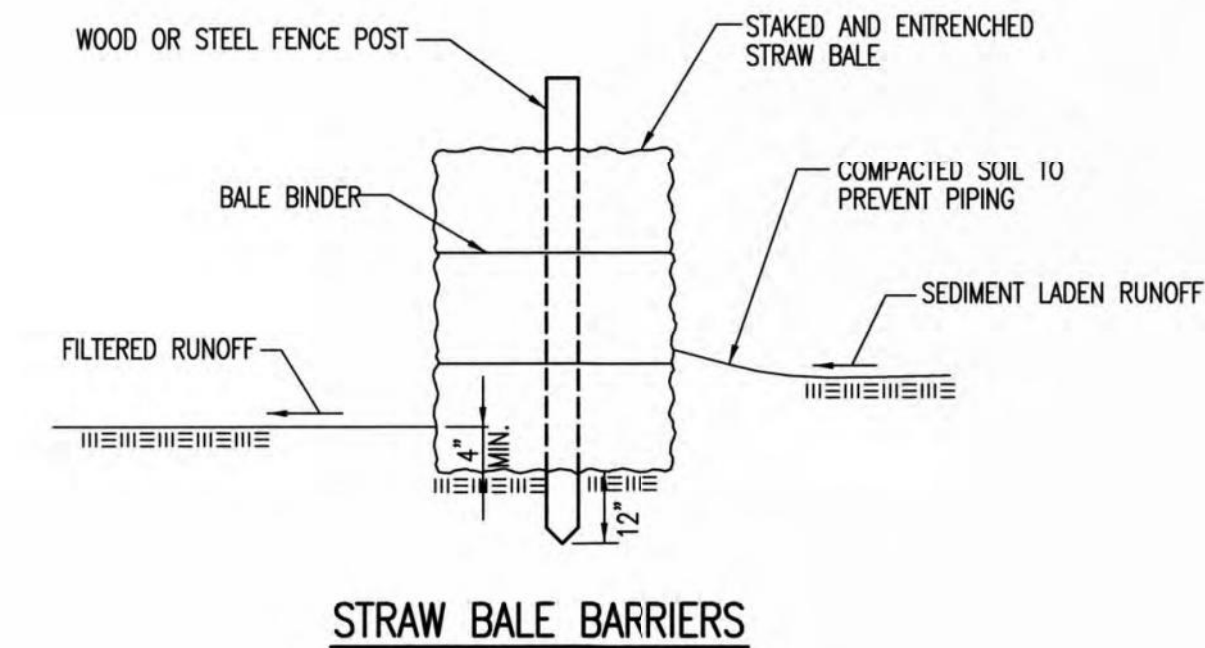

**MATERIAL SPECIFICATION:**

BALE SLOPE BARRIERS MAY BE CONSTRUCTED OF WHEAT STRAW, OAT STRAW, PRAIRIE HAY, OR BROMEGRASS HAY THAT IS FREE OF WEEDS DECLARED NOXIOUS BY THE KANSAS STATE BOARD OF AGRICULTURE. THE STAKES USED TO ANCHOR THE BALES SHOULD BE A HARDWOOD MATERIAL WITH THE FOLLOWING MINIMUM DIMENSIONS: 2" SQUARE (NOMINAL) BY 4' LONG. TWINE SHOULD BE USED TO BIND BALES. THE USE OF WIRE BINDING IS PROHIBITED BECAUSE IT DOES NOT BIODEGRADE READILY.

**PLACEMENT:**

A SLOPE BARRIER SHOULD BE USED AT THE TOE OF A SLOPE WHEN A DITCH DOES NOT EXIST. THE SLOPE BARRIER SHOULD BE PLACED ON NEARLY LEVEL GROUND 5' TO 10' AWAY FROM THE TOE OF A SLOPE. THE BARRIER IS PLACED AWAY FROM THE TOE OF THE SLOPE TO PROVIDE ADEQUATE STORAGE FOR SETTLING OUT SEDIMENT. WHEN PRACTICABLE, BALE SLOPE BARRIERS SHOULD BE PLACED ALONG CONTOURS TO AVOID A CONCENTRATION OF FLOW. BALE SLOPE BARRIERS CAN ALSO BE PLACED ALONG RIGHT-OF-WAY FENCE LINES TO KEEP SEDIMENT FROM CROSSING ONTO ADJACENT PROPERTY. WHEN PLACED IN THIS MANNER, THE SLOPE BARRIER WILL NOT LIKELY FOLLOW CONTOURS.

**PROPER INSTALLATION METHOD:**

EXCAVATE A TRENCH THE LENGTH OF THE PLANNED SLOPE BARRIER THAT IS 4" DEEP AND A BALE'S WIDTH WIDE. MAKE SURE THAT THE TRENCH IS EXCAVATED ALONG A SINGLE CONTOUR. WHEN PRACTICABLE, SLOPE BARRIERS SHOULD BE PLACED ALONG CONTOURS TO AVOID A CONCENTRATION OF FLOW. PLACE THE SOIL ON THE UPSLOPE SIDE OF THE TRENCH FOR LATER USE. PLACE THE BALES IN THE TRENCH, MAKING SURE THAT THEY ARE BUTTED TIGHTLY. TWO STAKES SHOULD BE DRIVEN THROUGH EACH BALE ALONG THE CENTERLINE OF THE DITCH CHECK, APPROXIMATELY 6" TO 8" IN FROM THE BALE ENDS. STAKES SHOULD BE DRIVEN AT LEAST 12" INTO THE GROUND. ONCE ALL THE BALES HAVE BEEN INSTALLED AND ANCHORED, PLACE THE EXCAVATED SOIL AGAINST THE UPSLOPE SIDE OF THE CHECK AND COMPACT IT. THE COMPACTED SOIL SHOULD BE NO MORE THAN 3" TO 4" DEEP.

**LIST OF COMMON PLACEMENT/INSTALLATION MISTAKES TO AVOID:**

WHEN PRACTICAL, DO NOT PLACE BALE SLOPE BARRIERS ACROSS CONTOURS. SLOPE BARRIERS SHOULD BE PLACED ALONG CONTOURS TO AVOID A CONCENTRATION OF FLOW. CONCENTRATED FLOW OVER A SLOPE BARRIER CREATES A SCOUR HOLE ON THE DOWNSLOPE SIDE OF THE BARRIER. THE SCOUR HOLE EVENTUALLY UNDERMINES THE BALES AND THE BARRIER FAILS. DO NOT PLACE BALE SLOPE BARRIERS IN AREAS WITH SHALLOW SOILS UNDERLAIN BY ROCK. IF THE BARRIER IS NOT ANCHORED SUFFICIENTLY, IT WILL WASH OUT. BALE SLOPE BARRIERS MUST BE DUG INTO THE GROUND. BALES AT GROUND LEVEL DO NOT WORK BECAUSE THEY ALLOW WATER TO FLOW UNDER THE BARRIER.

**INSPECTION AND MAINTENANCE:**

BALE SLOPE BARRIERS SHOULD BE INSPECTED EVERY 7 DAYS AND WITHIN 24 HOURS OF A RAINFALL OF 1/2" OR MORE. THE FOLLOWING IS A LIST OF QUESTIONS THAT SHOULD BE ADDRESSED DURING EACH INSPECTION:  
DOES WATER FLOW UNDER THE SLOPE BARRIER?  
DOES WATER FLOW THROUGH SPACES BETWEEN ABUTTING BALES?  
ARE ANY BALES DISLODGED?  
ARE BALES DECOMPOSING DUE TO AGE AND/OR WATER DAMAGE?  
DOES SEDIMENT NEED TO BE REMOVED FROM BEHIND THE SLOPE BARRIER?

REVISION DATE: MAY 2013



**STRAW BALE DITCH CHECK AND BARRIER DETAILS**

CITY ENGINEER  
**GARY JANZEN, P.E.**

PROJECT NUMBER    OCA NUMBER    DATE

CITY ENGINEER'S OFFICE  
CITY HALL - SEVENTH FLOOR  
455 NORTH MAIN STREET  
WICHITA, KANSAS 67202-1620  
(316) 268-4501

SHEET



Issue	Date	By	Description
0	8-4-2021	KLH	ISSUE FOR CONSTRUCTION

Drawn By: BNH  
Checked By: KLH  
Date: 8/4/2021  
Issue No. 0



Client:  
**SLAWSON EAST, INC.**  
727 N. WACO, SUITE 400  
WICHITA, KS 67203

CONDOMINIUM STORAGE  
**EROSION CONTROL DETAILS**  
WICHITA, KANSAS

Sheet No.  
**EC103**  
Project No.  
**2534**

PLACED DESIGN 2021, CONSTRUCTION 2021, CITY OF WICHITA, KS 67202-1620, 316.268.4501, 455 NORTH MAIN STREET, WICHITA, KANSAS 67202-1620

GENERAL NOTES

- THIS SHEET IS INTENDED TO PROVIDE GUIDELINES AS TO WHAT TYPES OF EROSION CONTROL DEVICES WILL BE INSTALLED DURING THE CONSTRUCTION PROCESS. CONTRACTORS ARE EXPECTED TO BID PROJECTS ACCORDINGLY.
- EROSION CONTROL DEVICES MUST BE MAINTAINED BY THE CONTRACTOR THROUGHOUT THE CONSTRUCTION PROCESS AND UNTIL THE DISTURBED EARTH IS RESTABILIZED.
- IF THE PROJECT WILL DISTURB 1 ACRE OR MORE, A FEDERAL/STATE NPDES STORMWATER PERMIT IS REQUIRED. A DETAILED STORMWATER POLLUTION PREVENTION PLAN, IS REQUIRED. THE EROSION CONTROL DEVICES SHOWN ON THIS SHEET ARE CONSIDERED TO BE THE MINIMUM TO BE SHOWN IN THE POLLUTION PREVENTION PLAN.
- FOR PROJECTS DISTURBING LESS THAN 1 ACRE, CONTRACTORS ARE ENCOURAGED TO PREPARE STORMWATER POLLUTION PREVENTION PLANS PRIOR TO CONSTRUCTION. EROSION CONTROL DEVICES MUST BE USED ON ALL PROJECTS.
- FAILURE TO USE AND MAINTAIN EROSION CONTROL DEVICES IS A VIOLATION OF SECTION 16.32 OF THE CITY CODE AND WILL SUBJECT THE CONTRACTOR TO THE PENALTIES PROVIDED FOR THEREIN.
- THE APPLICATION OF EROSION CONTROL DEVICES SHOWN ON THIS SHEET IS FOR SITUATIONS NORMALLY ENCOUNTERED. FROM TIME TO TIME, SITUATIONS WILL ARISE THAT MAY REQUIRE A DIFFERENT DEVICE OTHER THAN THOSE SHOWN. EROSION CONTROL DEVICES, OTHER THAN THOSE SHOWN, MAY BE UTILIZED AS LONG AS THEY ARE EFFECTIVE AND MAINTAINED.

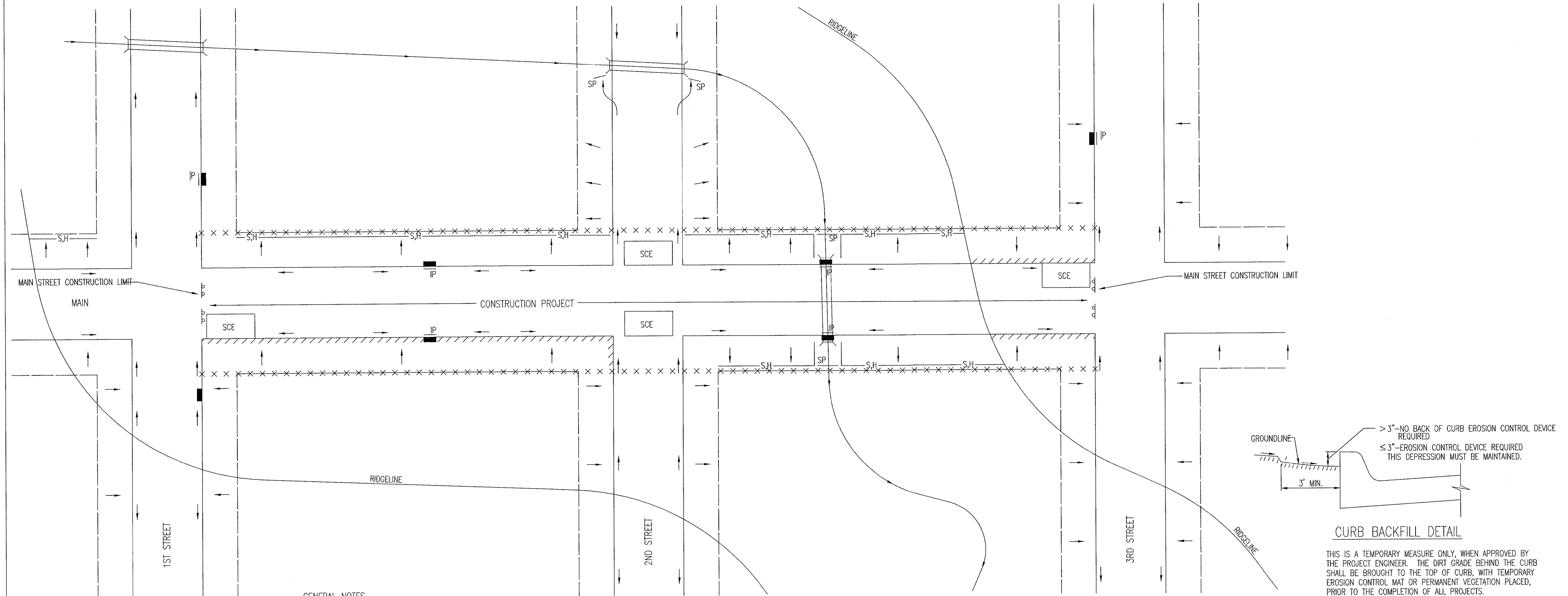

LEGEND

- R-O-W LIMITS
- DRAINAGE FLOW PATH
- × × × × R/W LIMIT WITHIN CONSTRUCTION LIMIT
- STORM WATER INLETS
- IP INLET PROTECTION
- S.H.— SILT FENCE OR HAY BALE BARRIER
- SP— STREAM PROTECTION
- SCE STABILIZED CONSTRUCTION ENTRANCE
- ////// BACK OF CURB PROTECTION

GENERAL NOTES

- THE INTENT OF ALL EROSION CONTROL DEVICES IS TO KEEP ALL SEDIMENT CONFINED TO THE CONSTRUCTION SITE, AND OUT OF ALL UNDERGROUND PIPES, DITCHES, LAKES, AND OTHER DRAINAGE FACILITIES, AND OFF OF STREETS.
- THE POINT OF COMPLIANCE IS GENERALLY THE RIGHT-OF-WAY LINES WITHIN THE LIMITS OF CONSTRUCTION.
- EROSION CONTROL DEVICES WILL BE REQUIRED AT ALL POINTS ALONG THE PROJECT WHERE DISTURBED EARTH CAN DRAIN ONTO PRIVATE PROPERTY.
- INLET PROTECTION DEVICES WILL BE REQUIRED WHEREVER WATER CAN DRAIN OFF THE PROJECT SITE INTO AN INLET, INCLUDING ANY SIDE STREET INLETS.
- EROSION CONTROL DEVICES SHALL BE INSTALLED AT CREEK CROSSINGS SO AS TO PREVENT SEDIMENT FROM ENTERING THEREIN.
- STABILIZED CONSTRUCTION ENTRANCES SHALL BE PROVIDED, AS NEEDED, TO PREVENT MUD FROM TRACKING ONTO STREETS NOT UNDER CONSTRUCTION AND ON STREETS WITHIN THE PROJECT LIMITS IF TRAFFIC IS BEING MAINTAINED THROUGH THE PROJECT.
- ANY MUD TRACKED ONTO STREETS MUST BE REMOVED AT THE END OF EACH WORK DAY.
- THE CONTRACTOR WILL BE REQUIRED TO PLACE EROSION CONTROL DEVICES BACK OF CURB, WHENEVER WATER CAN DRAIN OVER CURB, TO KEEP ERODED SOIL OUT OF THE GUTTERLINES, IN ACCORDANCE WITH THE FOLLOWING:
  - THE DEVICE REQUIRED WILL BE APPROVED EROSION CONTROL MAT LISTED ON THE CITY'S APPROVED MATERIAL LIST. SAID BLANKET SHALL BE PLACED OVER THE APPROPRIATE SEED AND FERTILIZER, AS SPECIFIED IN THE PROJECT SPECIFICATIONS. (SEE SOIL EROSION BMPs - BACK OF CURB SEDIMENT BARRIER DETAILS)
  - THIS DEVICE SHALL BE INSTALLED IMMEDIATELY WHENEVER THE CURB IS BACKFILLED TO WITHIN 3" OF THE TOP OF CURB. (SEE CURB BACKFILL DETAIL)
  - ADDITIONALLY, OTHER EROSION CONTROL DEVICES (HAY BALES, SILT FENCE, ETC.) WILL BE INSTALLED AT LOCATIONS OF CONCENTRATED FLOW RESULTING IN SEDIMENT OVERRUNNING THE MAT.
  - SHOULD THE PROJECT PLANS SPECIFY THAT THE RIGHT-OF-WAY IS TO BE SODDED, THE EXCELSIOR MAT WILL NOT BE REQUIRED SO LONG AS THE SOD IS PLACED WITHIN 48 HOURS AFTER CURB BACKFILL REACHES A HEIGHT OF 3" OR LESS FROM TOP OF CURB. (SEE CURB BACKFILL DETAIL)



REVISION: JUNE 2015

<b>STREET IMPROVEMENT PROJECTS</b>		
CITY ENGINEER <b>GARY JANZEN, P.E.</b>		
PROJECT NUMBER 2534	OCA NUMBER	DATE
CITY ENGINEER'S OFFICE CITY HALL - SEVENTH FLOOR 455 NORTH MAIN STREET WICHITA, KANSAS 67202-1620 (316) 268-4501		SHEET EC104



Issue	Date	By	Description
0	8-4-2021	KLH	ISSUE FOR CONSTRUCTION
Drawn By: BNH			Date: 8/4/2021
Checked By: KLH			Issue No. 0



Client:  
**SLAWSON EAST, INC.**  
727 N. WACO, SUITE 400  
WICHITA, KS 67203

CONDOMINIUM STORAGE  
**EROSION CONTROL DETAILS**  
WICHITA, KANSAS

Sheet No.  
**EC104**  
Project No.  
**2534**

PLANNET Desktop 2021, Central Invention, Inc., Copyright © 2021, Wichita, KS 67202-1620, PLANNET Desktop, Central Invention, Inc.

SW-504



Relines completed by Merestone

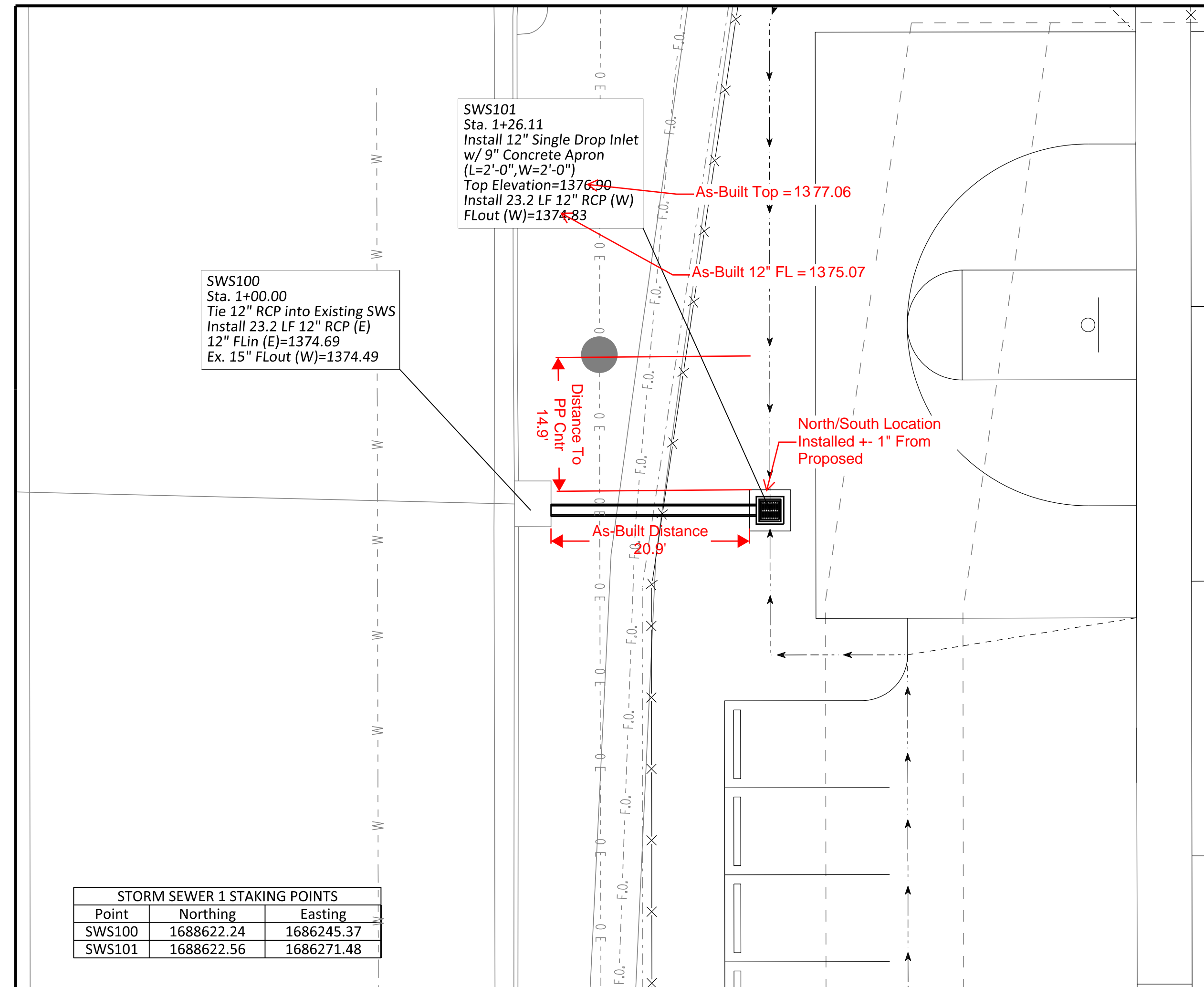

STORM SEWER 1 STAKING POINTS		
Point	Northing	Easting
SWS100	1688622.24	1686245.37
SWS101	1688622.56	1686271.48

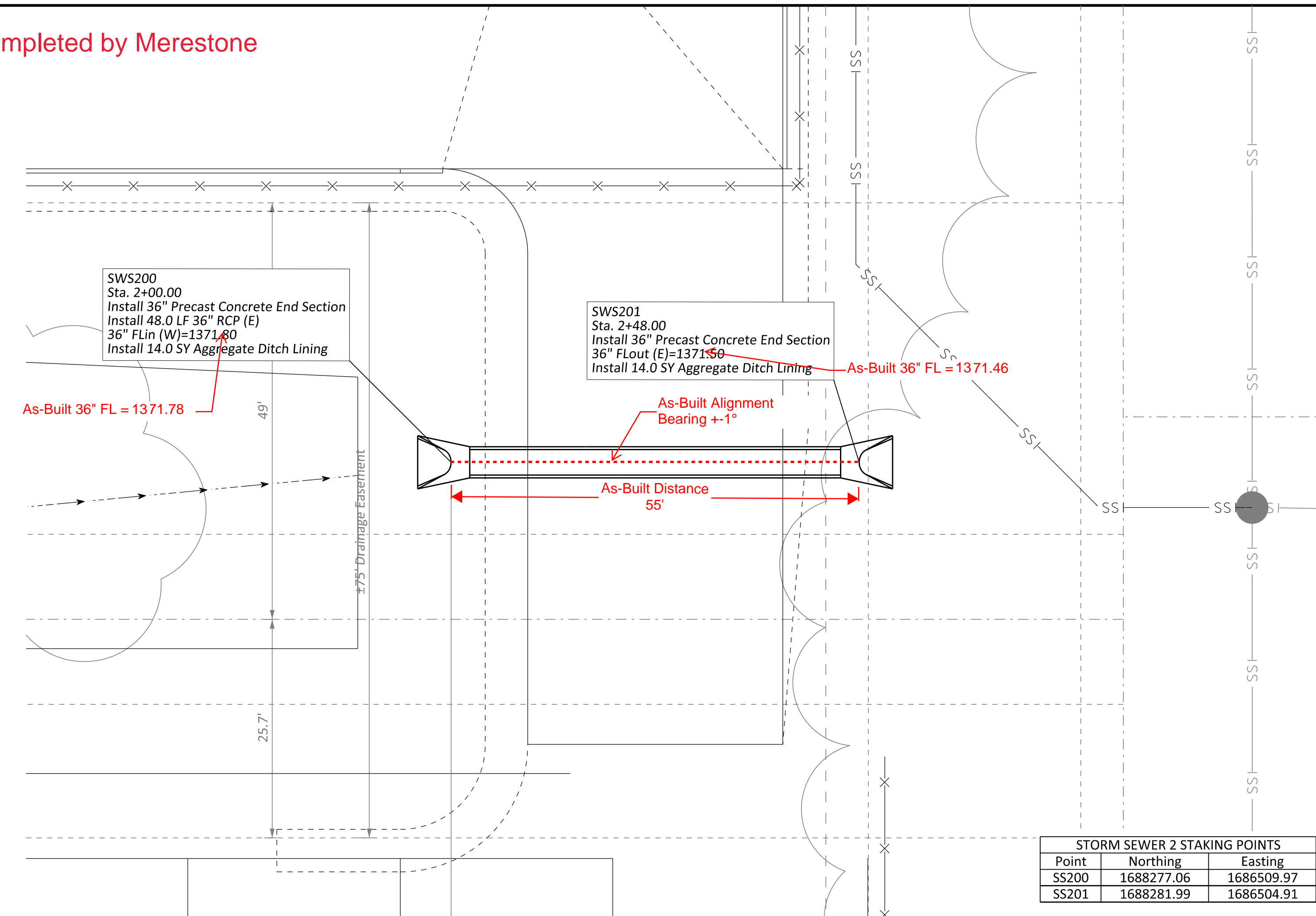

STORM SEWER 2 STAKING POINTS		
Point	Northing	Easting
SS200	1688277.06	1686509.97
SS201	1688281.99	1686504.91

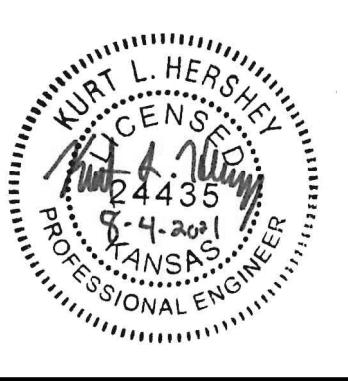
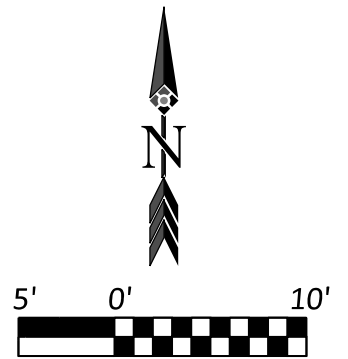
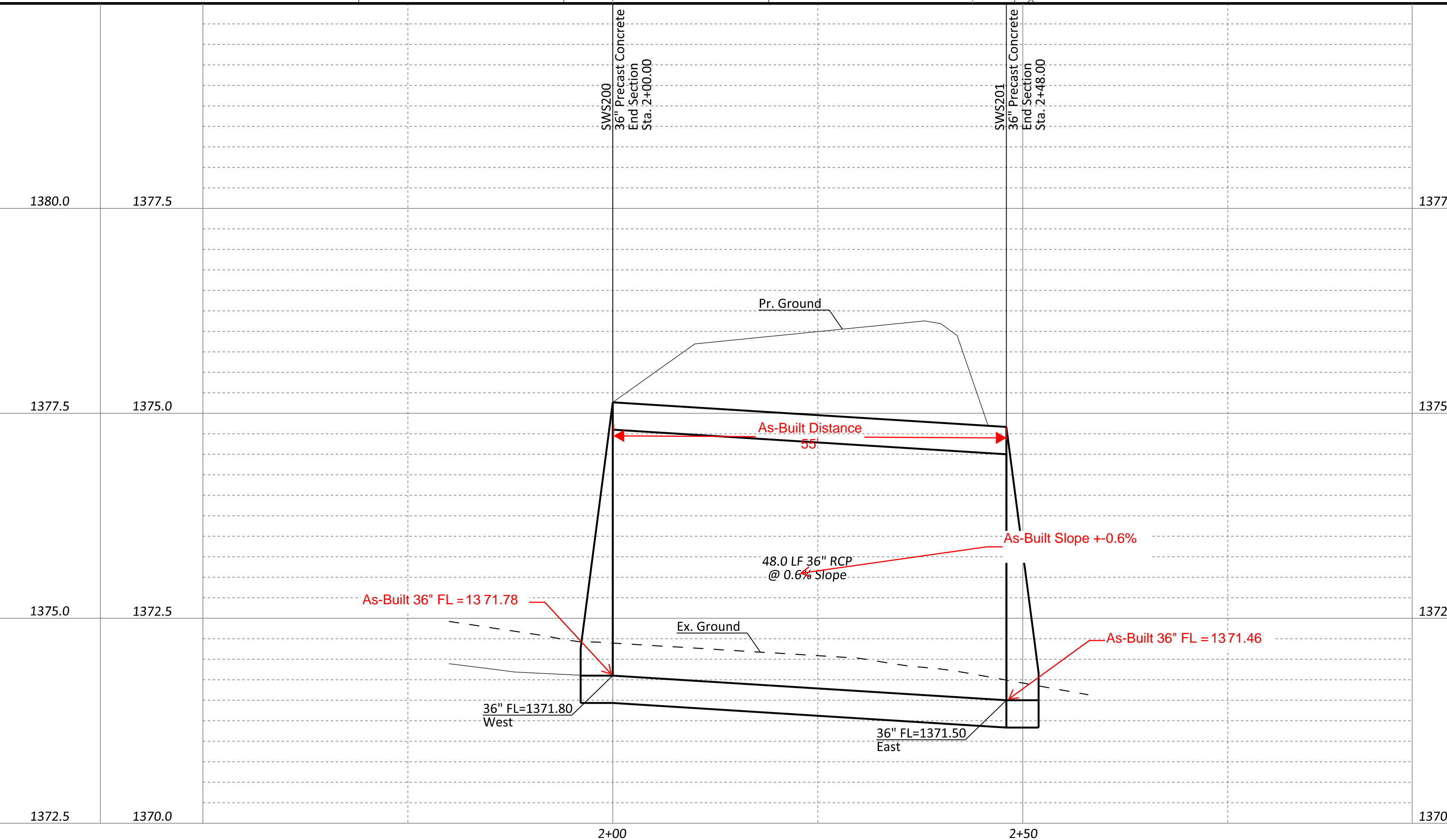
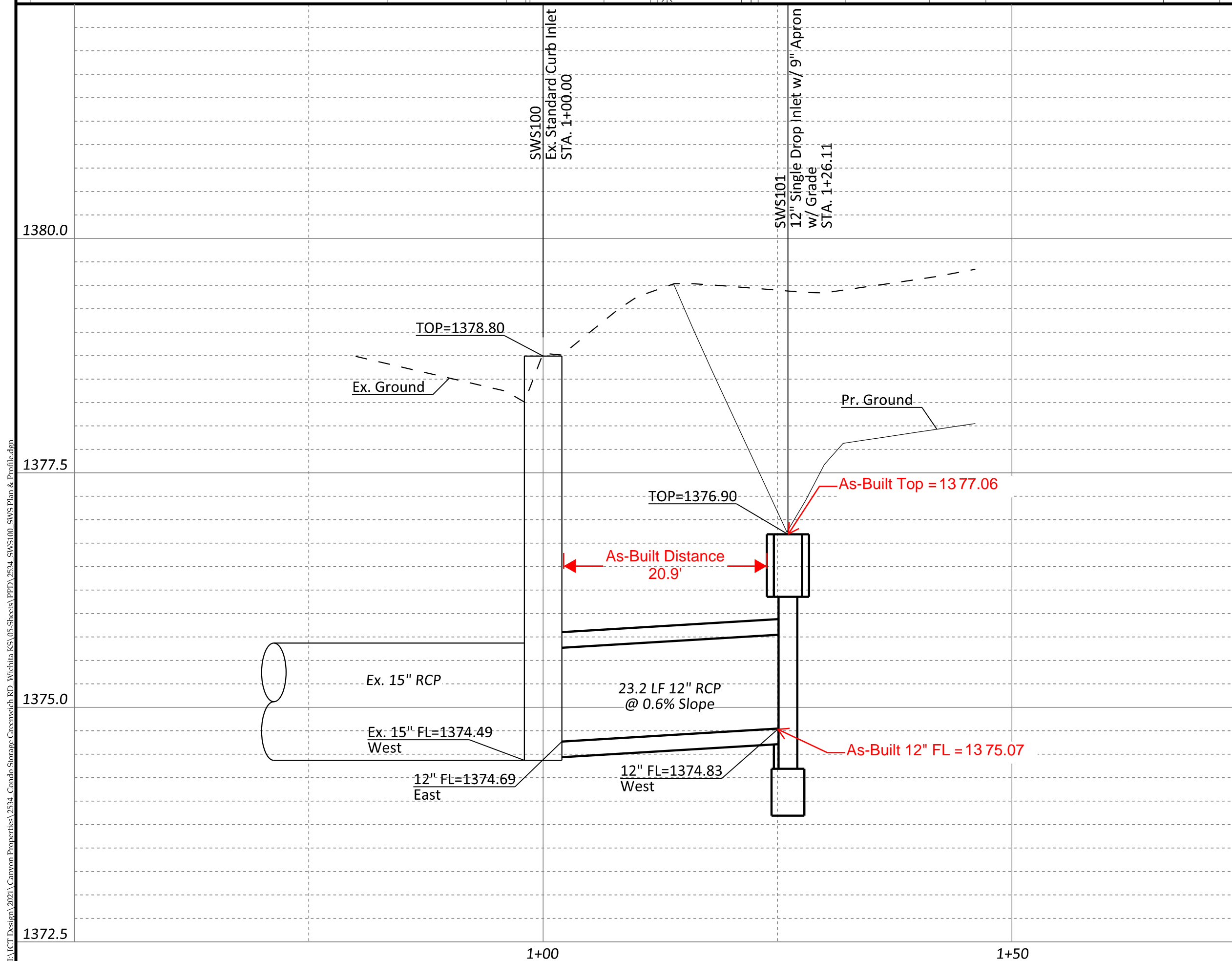

Issue	Date	By	Description
0	8-4-2021	KLH	ISSUE FOR CONSTRUCTION

Checked By: KLH  
Date: 8/4/2021  
Issue No. 0



Client: **SLAWSON EAST, INC.**  
727 N. WACO, SUITE 400  
WICHITA, KS 67203

CONDOMINIUM STORAGE  
**SWS LINE 1 & 2  
PLAN & PROFILE**  
WICHITA, KANSAS

Sheet No.  
**SWS100**  
Project No.  
**2534**



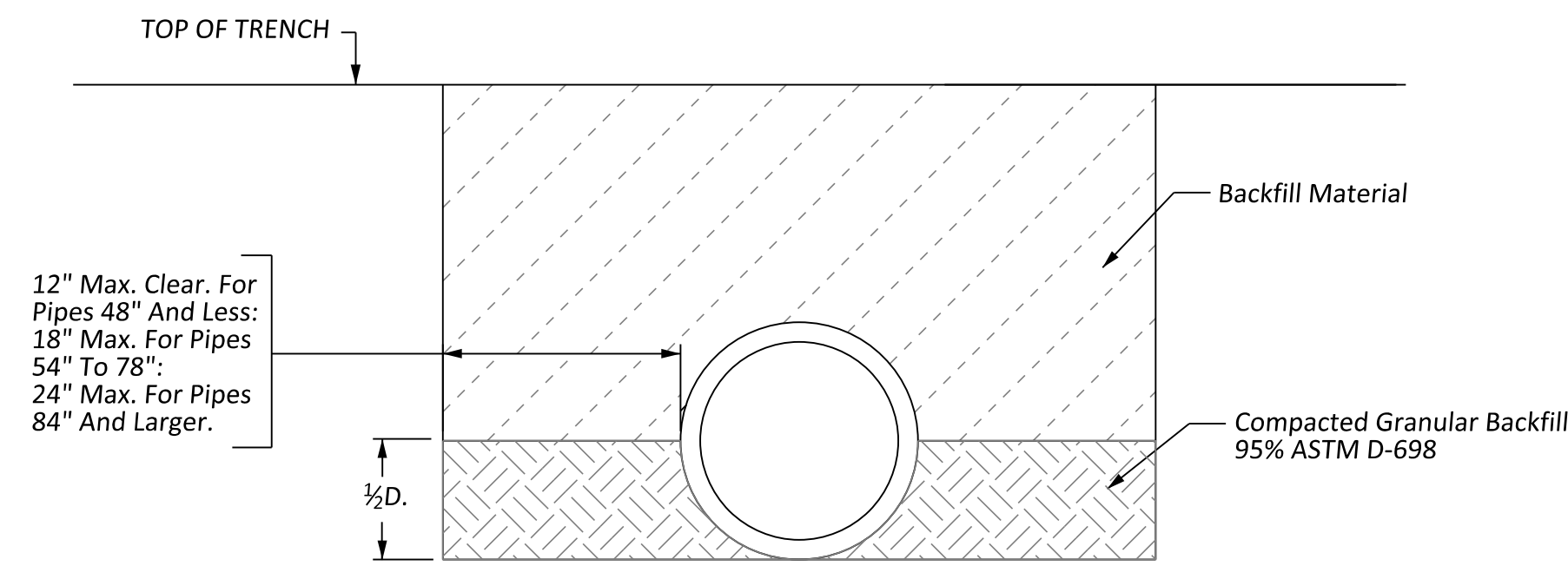

**YIELDING (SOIL) FOUNDATION**

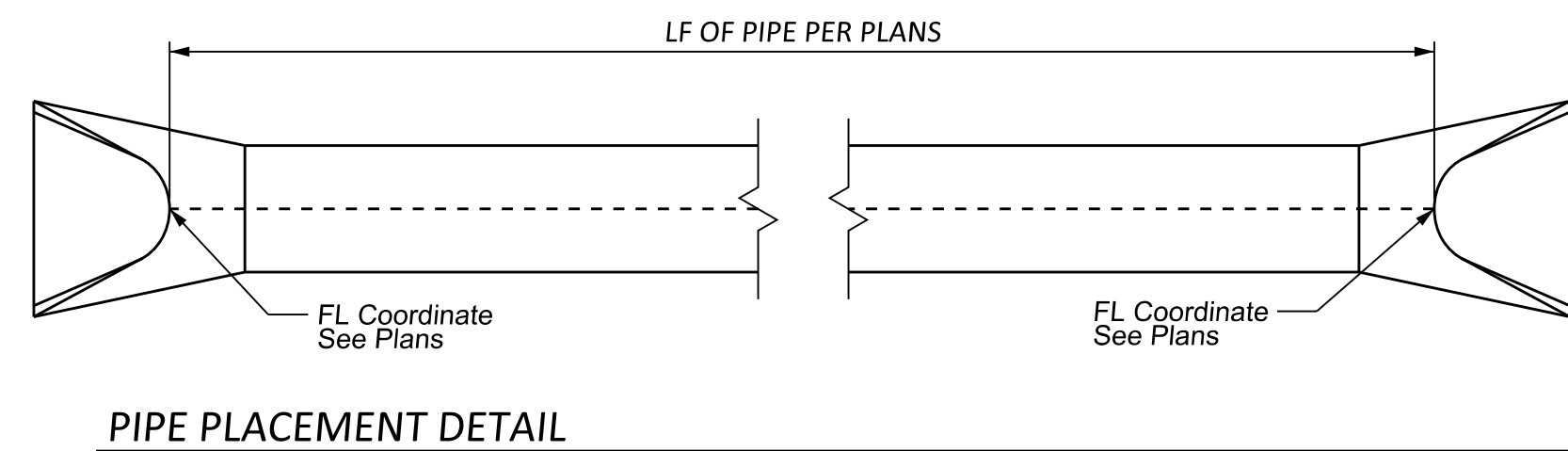

**PIPE PLACEMENT DETAIL**

**NOTES FOR RCP**

- All Reinforced Concrete Pipe shall be Class III or stronger based on ASTM C-76.
- Portland Cement Concrete used in RCP manufacturing shall either be Type I or Type II. Fly Ash may be substituted in Type II PCC at a rate of 25%. PCC used in RCP manufacturing shall have a 28-day compressive strength of 4 ksi.
- RCP dimensions shall conform to the table shown.

**RCP SPECIFICATIONS**

INSIDE DIAMETER	NOMINAL WALL THICKNESS	WEIGHT (lbs/ft)
12"	2.0"	100
15"	2.25"	128
18"	2.5"	168
24"	3.0"	268
30"	3.5"	385
36"	4.0"	524

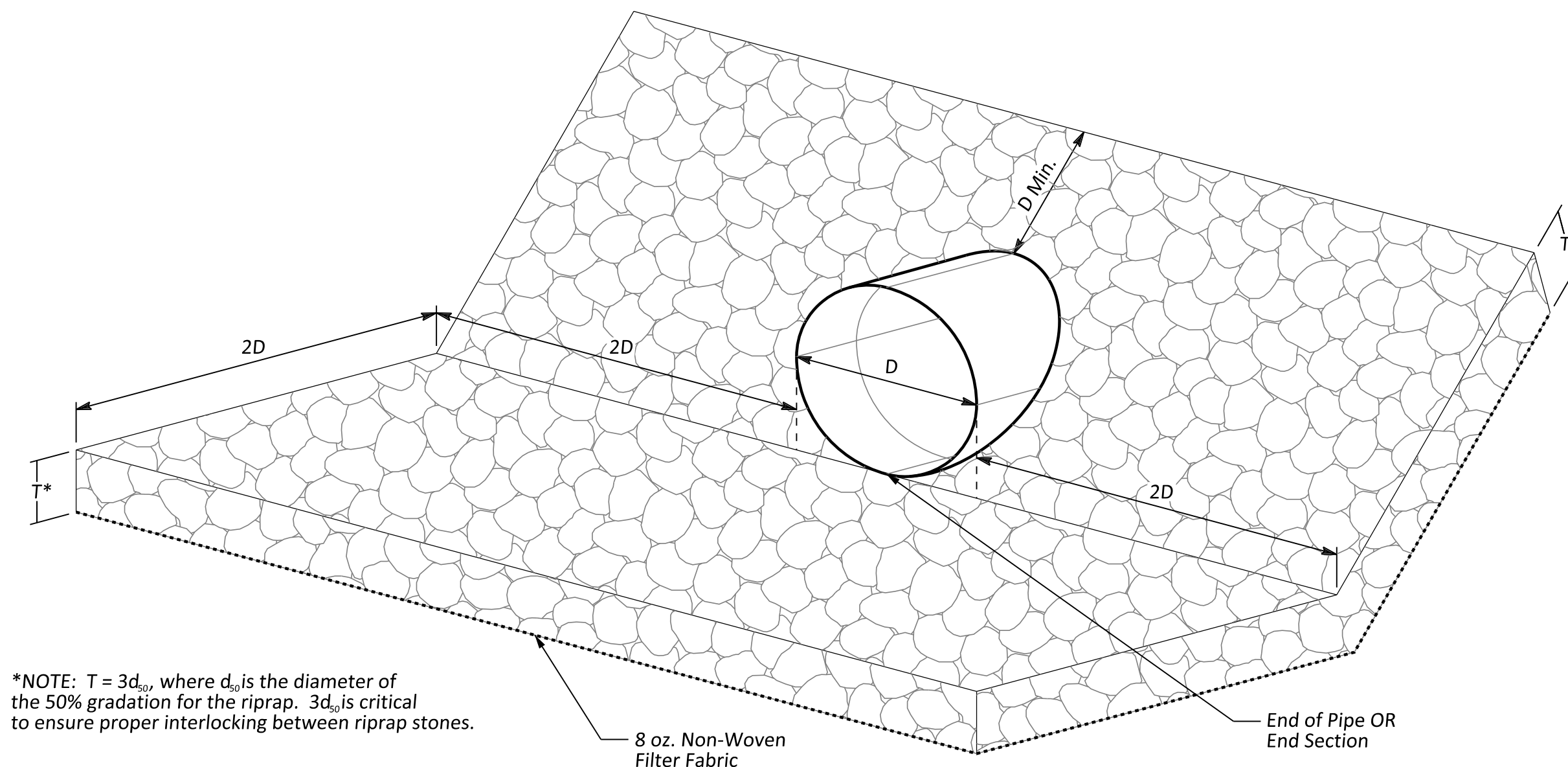

**RIPRAP INLET PROTECTION**

**AGGREGATE DITCH LINING NOTES**

- Stone for ditch lining shall be free from earth, chert, cracks, seams, soapstone, and shale or other easily disintegrated materials.
- Stone for ditch lining shall have a maximum LA Abrasion Loss of 45% (ASTM C535).
- Aggregate Ditch Lining shall meet the gradation shown in Table 1.
- Stone For Riprap shall meet the gradation shown in Table 2.

Sieve Size	8"	6-1/2"	6"	5"	4"	3"	2-1/2"
6" Light Stone	15		50			85	

**SUBMITTALS**

Contractor shall submit documentation to Engineer for approval at least (2) weeks prior to delivery on site verifying that all material to be used for project meets or exceeds project specifications. Material installed that has not been approved by Engineer may be required to be removed and replaced at Engineer's discretion. This removal & replacement will occur at Contractor's expense.

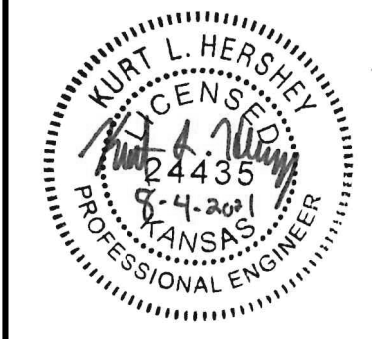

Issue	Date	By	Description
0	8-4-2021	KLH	ISSUE FOR CONSTRUCTION
-	-	-	-
-	-	-	-
-	-	-	-

Drawn By: BNH  
Checked By: KLH  
Date: 8/4/2021  
Issue No. 0



Client:  
**SLAWSON EAST, INC.**  
727 N. WACO, SUITE 400  
WICHITA, KS 67203

CONDOMINIUM STORAGE  
**STORM SEWER DETAILS**  
WICHITA, KANSAS

Sheet No.  
**SWS102**

Project No.  
**2534**

PROJECT: 20211 Convent Blvd, Wichita, KS 67203  
 CLIENT: Slawson East, Inc.  
 DATE: 8/4/2021  
 DRAWN BY: BNH  
 CHECKED BY: KLH  
 PROJECT NO: 2534

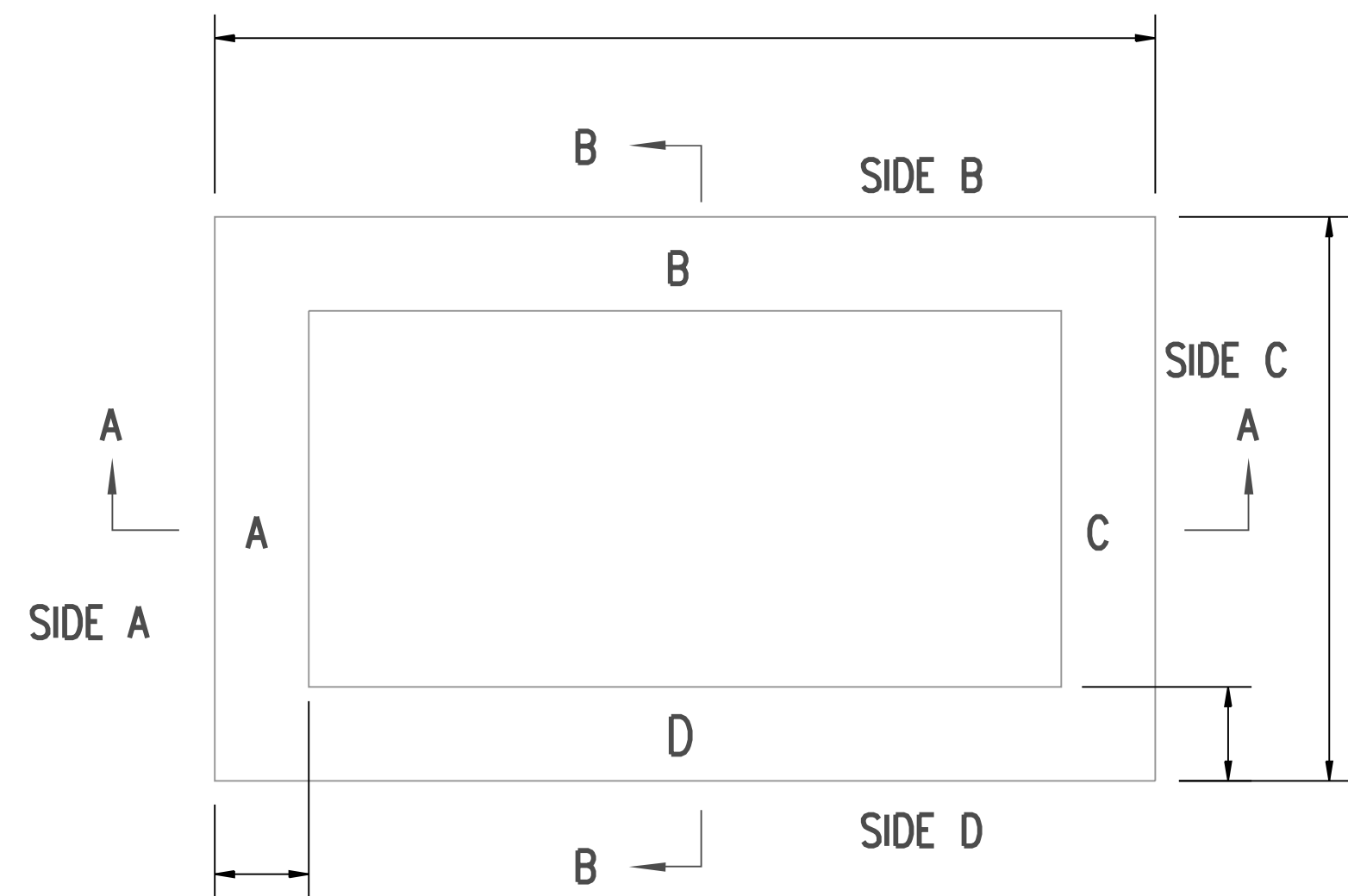

**TOP VIEW**

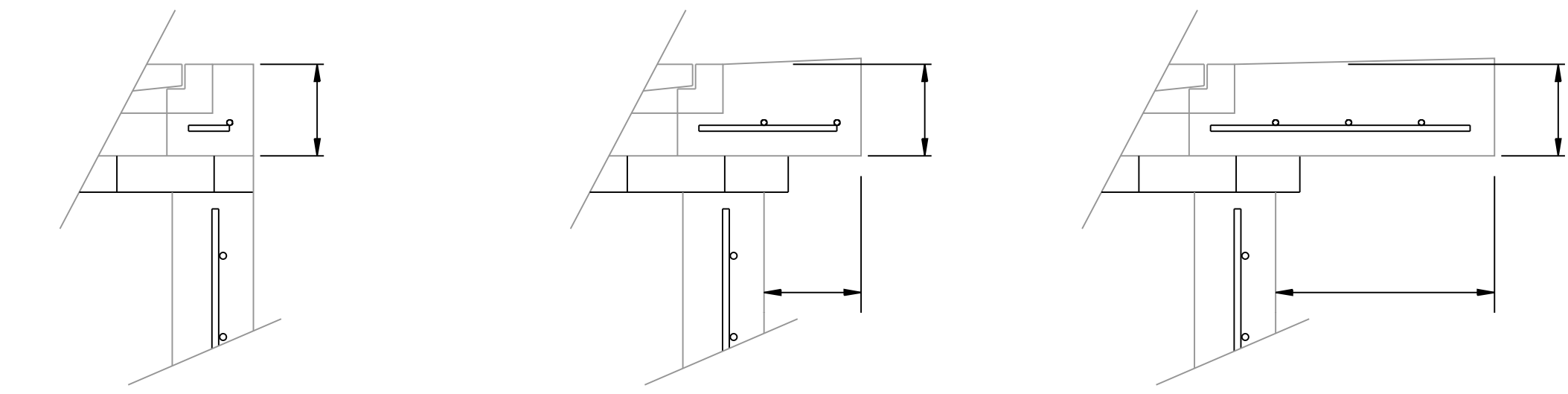

**FLUSH STYLE TOP  
NO APRON**

**9" APRON**

DESIGNER TO DESIGNATE APRON SIZE.

**18" APRON**

W=2' and L=2' for SINGLE DROP INLET  
W=2' and L=4' for DOUBLE DROP INLET

The structure(s) on this detail sheet are designed for HS-20 loading at these specific dimensions only. If larger dimensions are required, the ENGINEER shall provide a project specific structure design for approval by the City Engineer's office.

**GENERAL NOTES**

1. GRATE FRAME TO BE INSTALLED ON THIN MORTAR CUSHION TO INSURE FULL SUPPORT ALONG BRICK. CONCRETE USED FOR INLET CONSTRUCTION SHALL CONFORM TO CITY OF WICHITA SPECIFICATIONS FOR CONCRETE PAVEMENT MIX.
2. INLET INVERT SHALL BE SHAPED WITH 8 SACK SAND MIX CONCRETE TO CREATE FLOW CHANNELS AND TO INCREASE HYDRAULIC EFFICIENCY SUCH THAT THE INLET WILL BE SELF CLEANING BETWEEN ALL INLET AND/OR OUTLET PIPES.
3. THE ENDS OF ALL PIPES INSTALLED IN INLETS SHALL BE CUT OFF FLUSH WITH THE INSIDE FACE OF THE INLET WALL.
4. INLET FRAME AND GRATE TO BE DEETER #2433, EJIW #5391-Z1 OR APPROVED EQUAL FOR 2'x2' SINGLE DROP INLET AND DEETER #2434, EJIW #5391 Z3 OR APPROVED EQUAL FOR 2'x4' DOUBLE DROP INLET.
5. CONTRACTOR SHALL REMOVE LIFTING HOOKS AFTER INSTALLATION. RECESSES IN INLET WALL SHALL BE GROUTED FLUSH TO THE INLET WALL WITH HYDRAULIC CEMENT AFTER THE INLET IS IN PLACE. LIFTING HOLES THRU THE INLET WALL WILL NOT BE ACCEPTED.

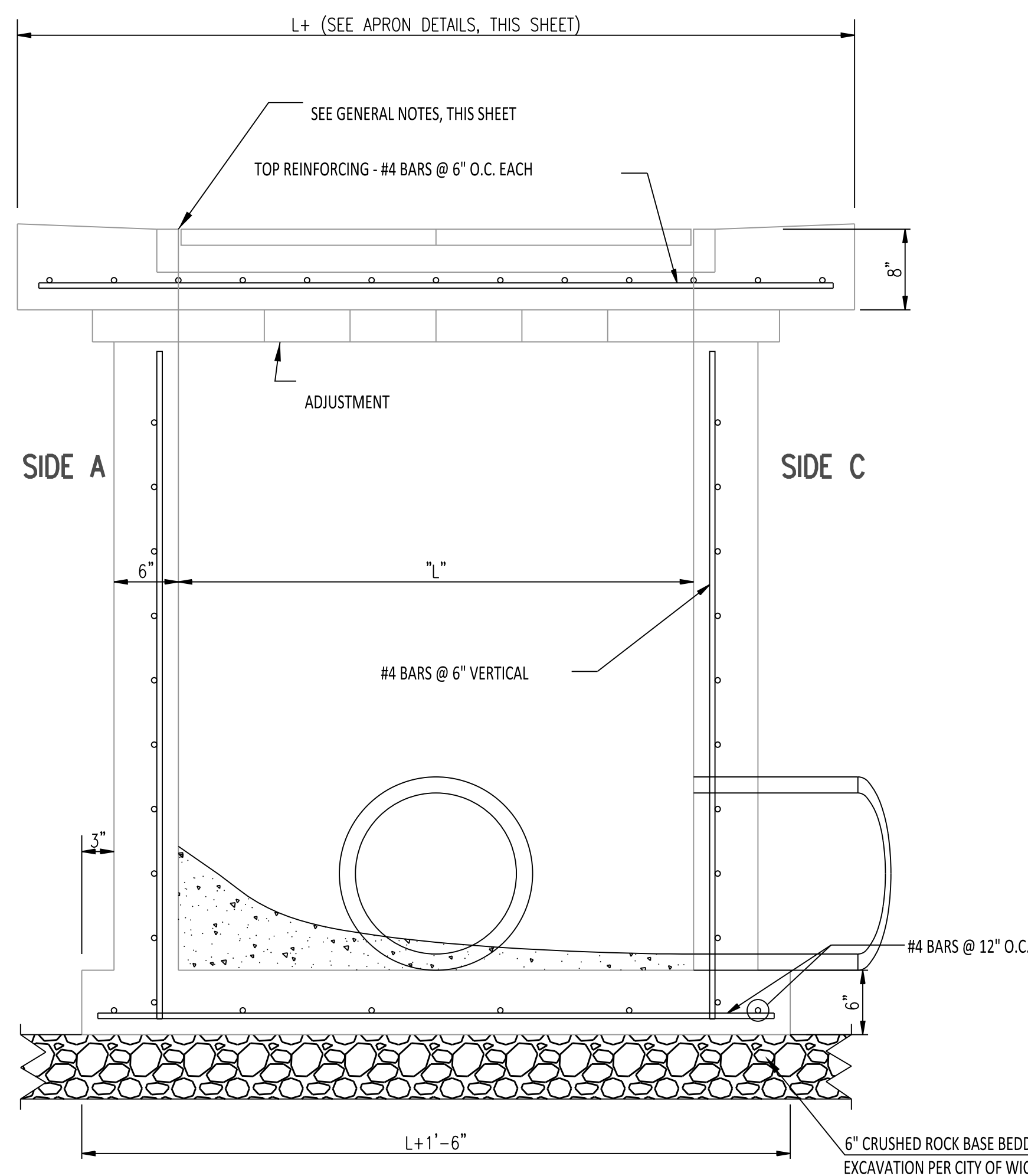

**SECTION "A-A"**

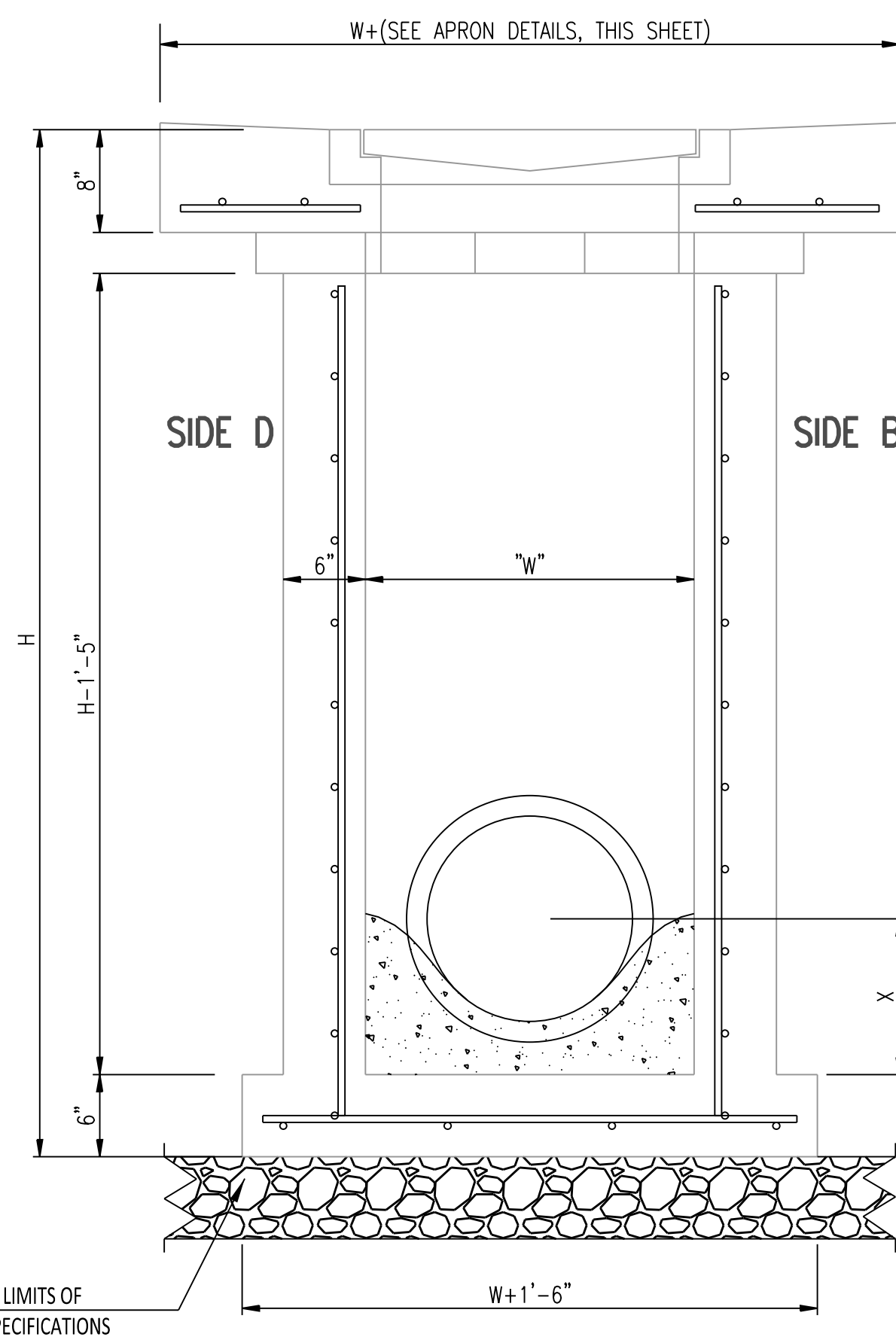

**SECTION "B-B"  
END OUTLET**

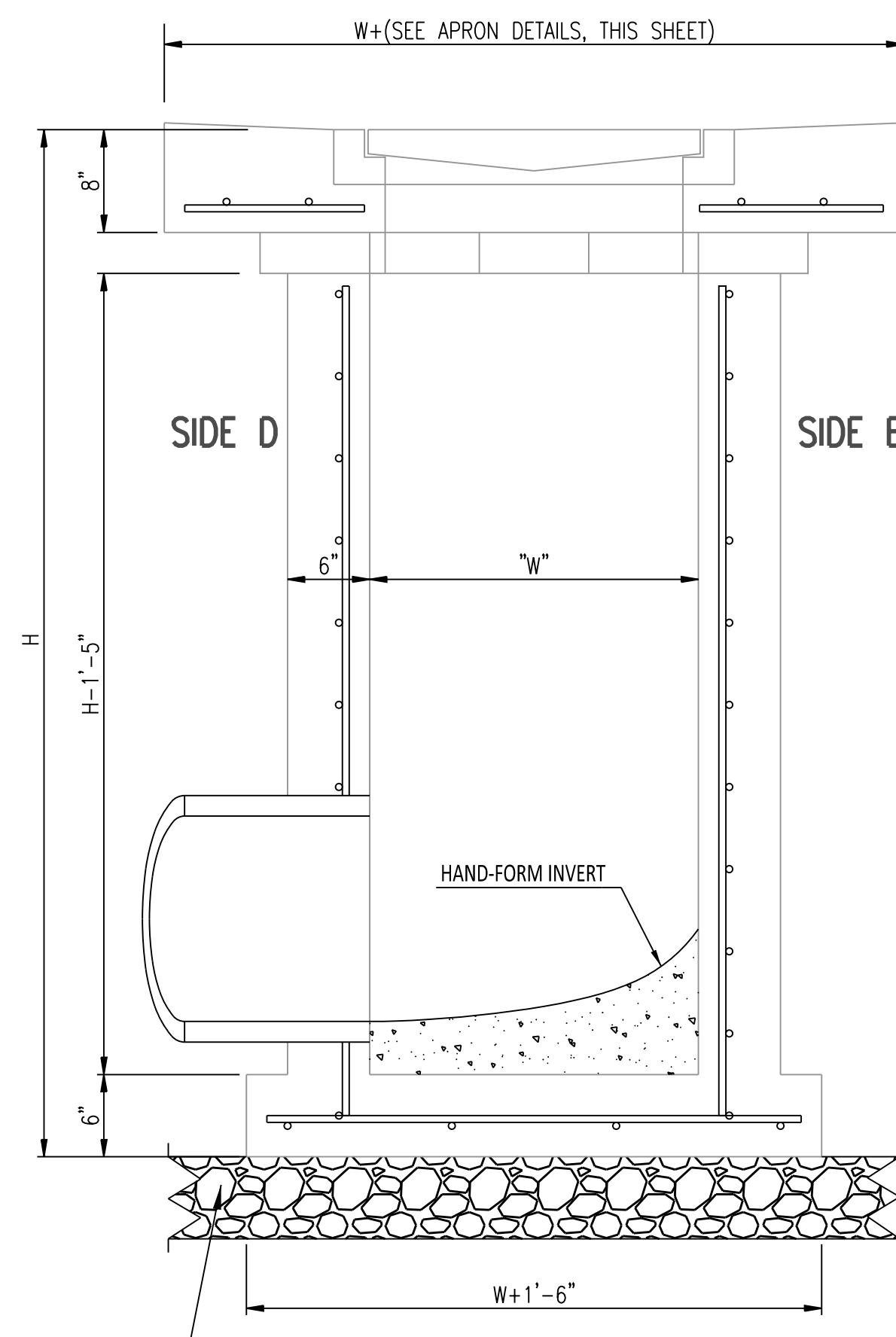

**SECTION "B-B"  
SIDE OUTLET**



**CITY OF  
WICHITA**  
PUBLIC WORKS & UTILITIES  
ENGINEERING DIVISION

REVISED: MARCH 2015

**SINGLE/DOUBLE  
DROP INLET**

CITY ENGINEER  
**GARY JANZEN, P.E.**

PROJECT NUMBER 2534	OCA NUMBER	DATE
------------------------	------------	------

CITY ENGINEER'S OFFICE  
CITY HALL - SEVENTH FLOOR  
455 NORTH MAIN STREET  
WICHITA, KANSAS 67202-1620  
(316) 268-4501

SHEET SWS103	DATE 8/4/2021
-----------------	------------------

Issue	Date	By	Description
0	8-4-2021	KLH	ISSUE FOR CONSTRUCTION

Drawn By: BNH  
Checked By: KLH  
Date: 8/4/2021  
Issue No. 0



Client:  
**SLAWSON  
EAST, INC.**  
727 N. WACO, SUITE 400  
WICHITA, KS 67203

CONDOMINIUM STORAGE  
**SINGLE-DOUBLE  
DROP INLET DETAILS**  
WICHITA, KANSAS

Sheet No.  
**SWS103**  
Project No.  
**2534**

PROJECT: 202111, General Inspection, 2534, City of Wichita, KS 67202, 202111, Single Double Drop Inlet.dwg