

BM #1 - City of Wichita  
 Benchmark Disc, SE Corner of  
 Clifton and 55th Street South,  
 Southwest corner of RCBC, on top  
 of hubguard at the West end.  
 ELEV. = 1263.29 NGVD29

BM #2 - "□" Cut on wall footing  
 located 29' North of the South  
 end of wall, at the Southeast  
 corner of Lot 7 Block A,  
 Meadowlake Beach Addition,  
 Sedgwick County, Kansas.  
 ELEV. = 1266.82 NGVD29

BM #3 - "□" Cut Top of Curb,  
 West side South end of Concrete  
 street North west of Northeast  
 corner of Meadowlake Beach  
 Addition, Sedgwick County, Kansas.  
 ELEV. = 1262.86 NGVD29

BM #4 - "□" Cut Top of Curb,  
 East return on East side of  
 Concrete street North of the  
 Northwest Corner of Meadowlake  
 Beach Addition, Sedgwick County,  
 Kansas.  
 ELEV. = 1262.95 NGVD29

Scale: 1" = 20' Horizontal  
 1" = 5' Vertical  
 • = Iron

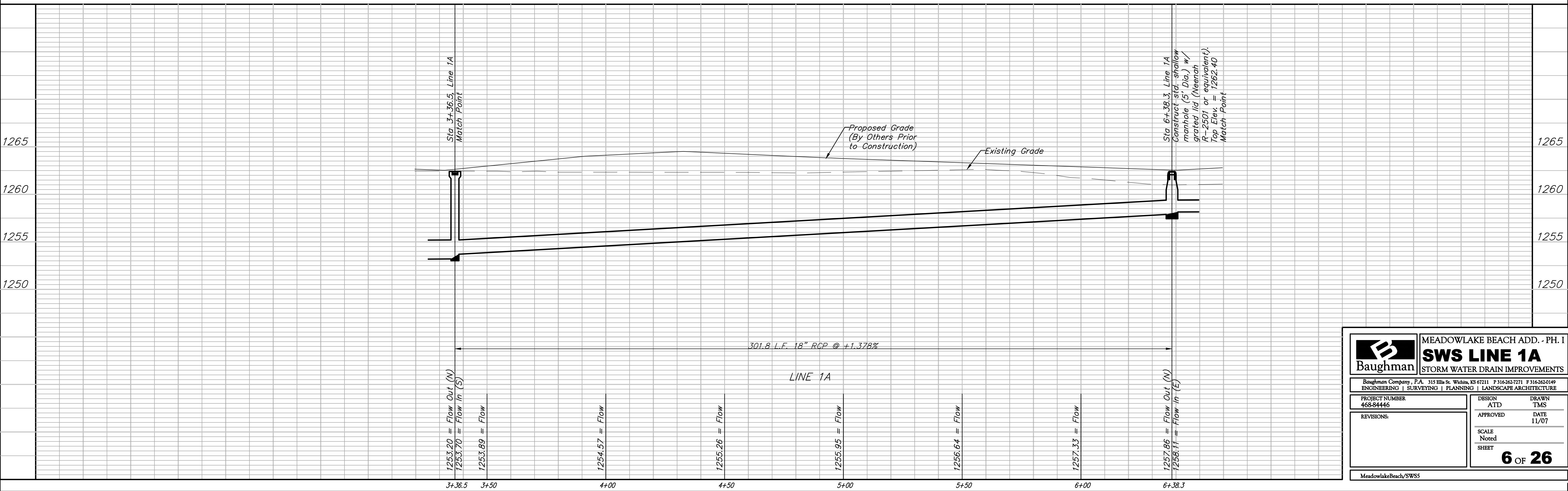
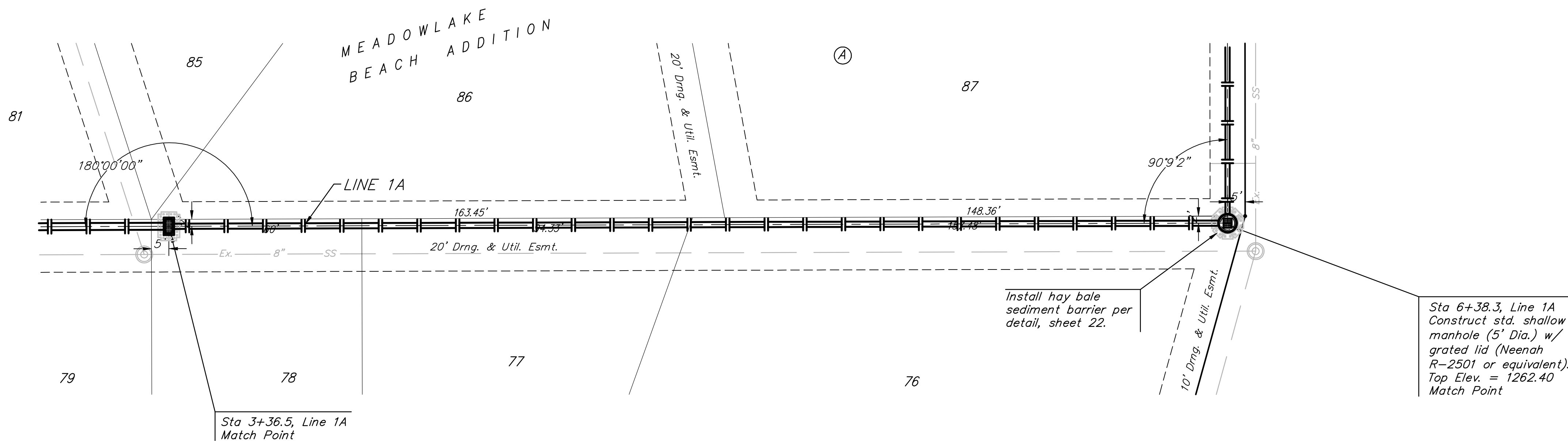

	MEADOWLAKE BEACH ADD. - PH. I	
	<b>SWS LINE 1A</b>	
STORM WATER DRAIN IMPROVEMENTS		
<small>Baughman Company, P.A. 315 Ellis St. Wichita, KS 67211 P 316-262-7271 F 316-262-0149          ENGINEERING   SURVEYING   PLANNING   LANDSCAPE ARCHITECTURE</small>		
PROJECT NUMBER 468-84446	DESIGN ATD	DRAWN TMS
REVISIONS:	APPROVED	DATE 11/07
SCALE Noted		SHEET <b>6 OF 26</b>
<small>MeadowlakeBeach/SWS5</small>		