

STATE	PROJECT NO.	YEAR	SHEET NO.	TOTAL SHEETS
KANSAS	54-87 K-6657-01	2002	558	1122

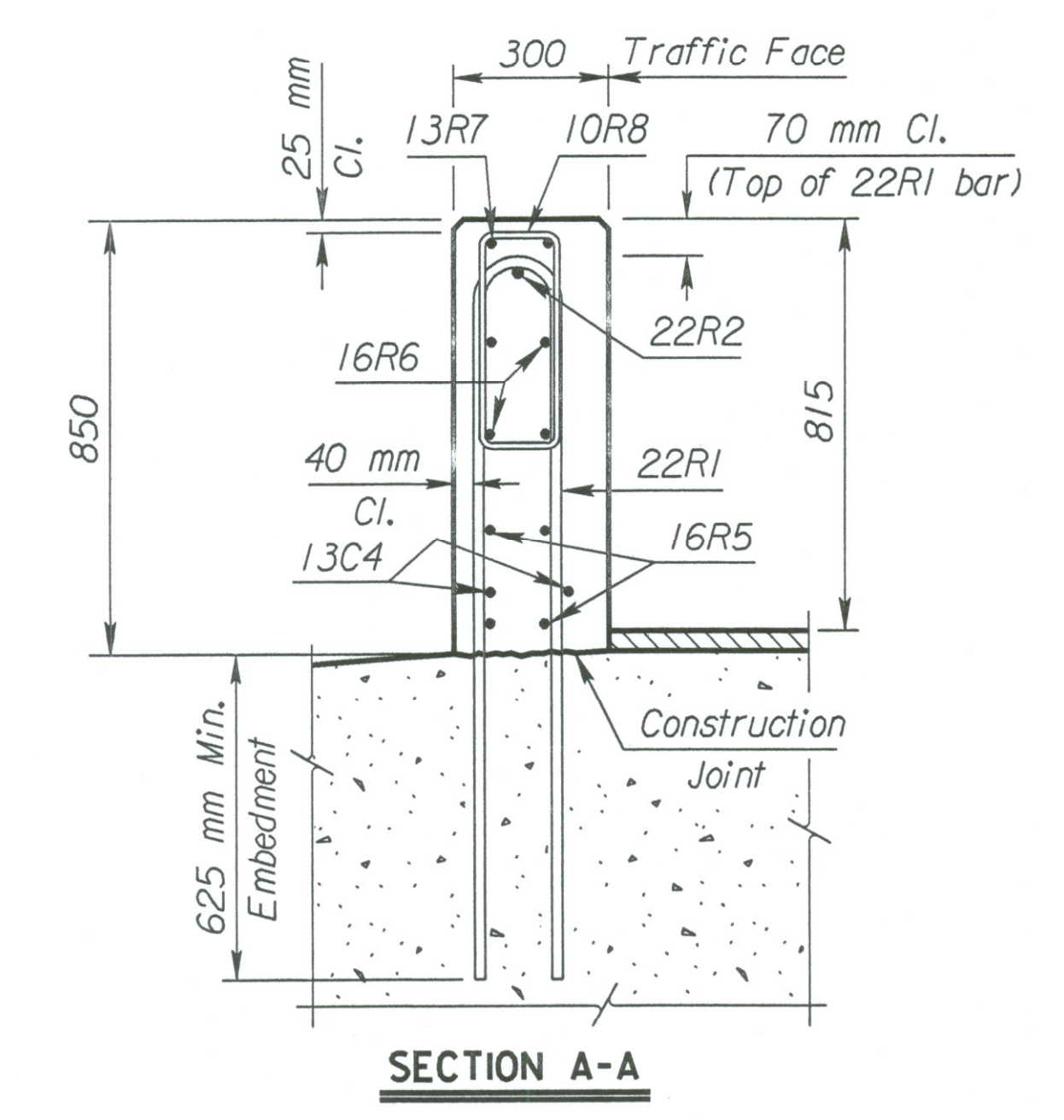
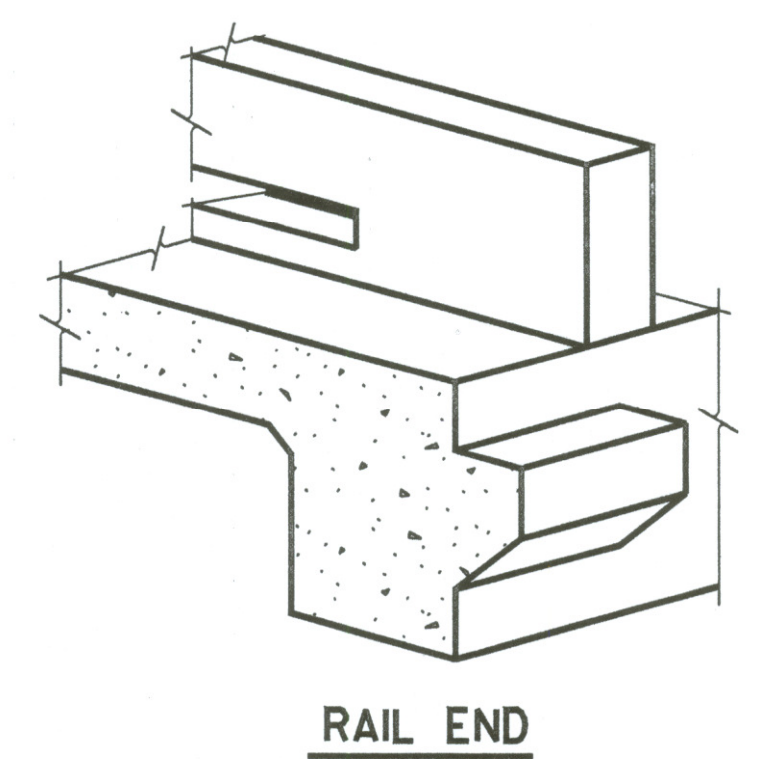
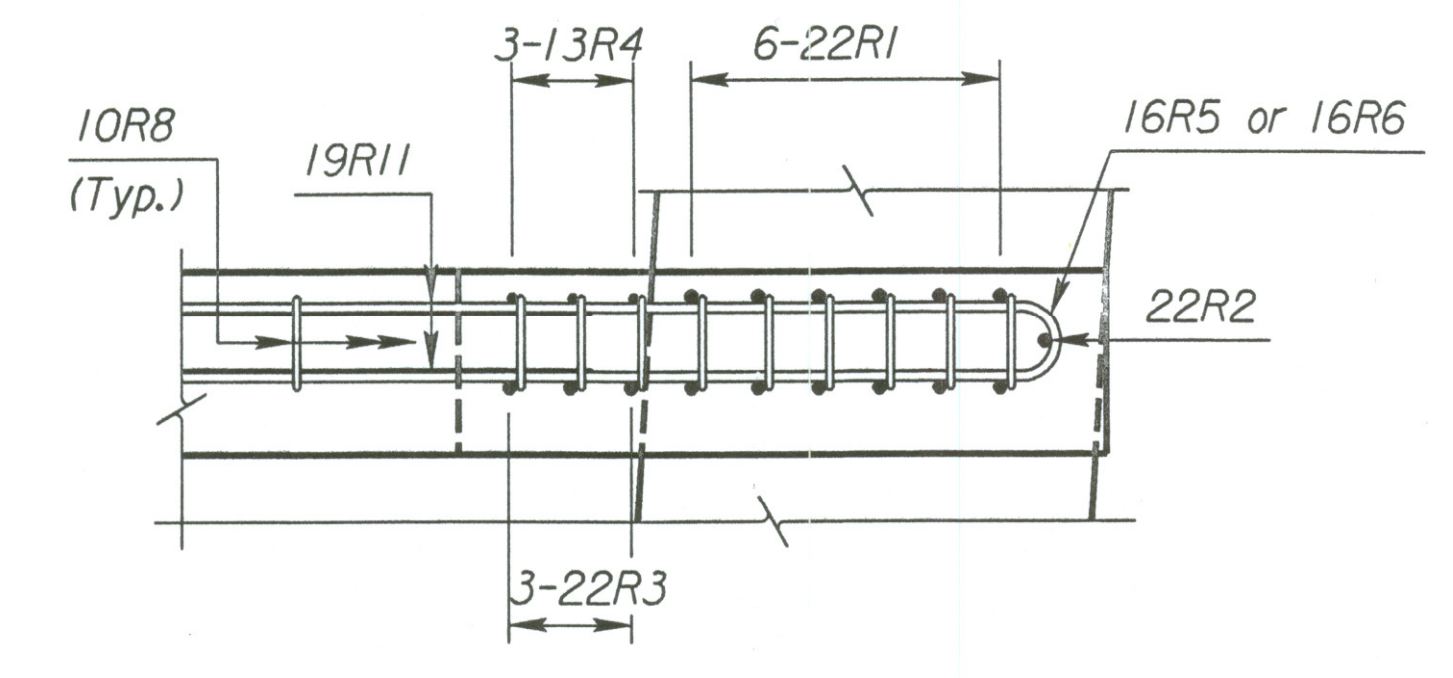
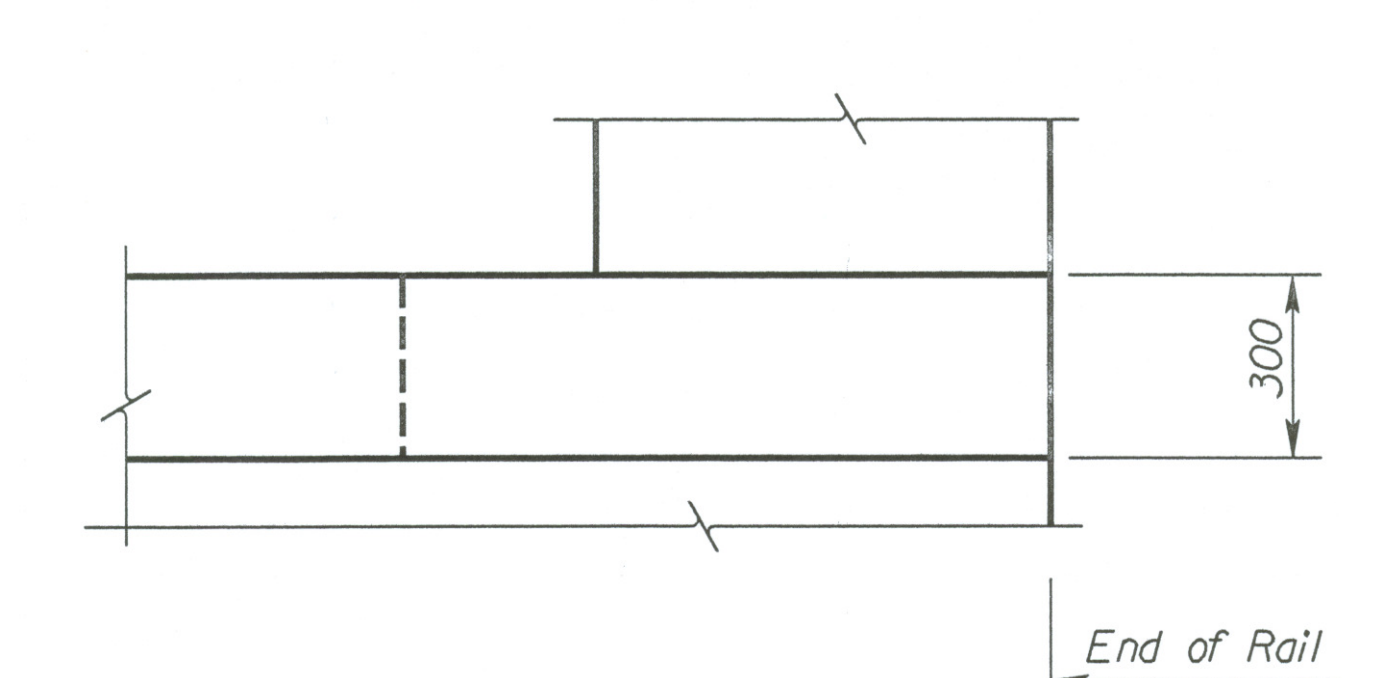
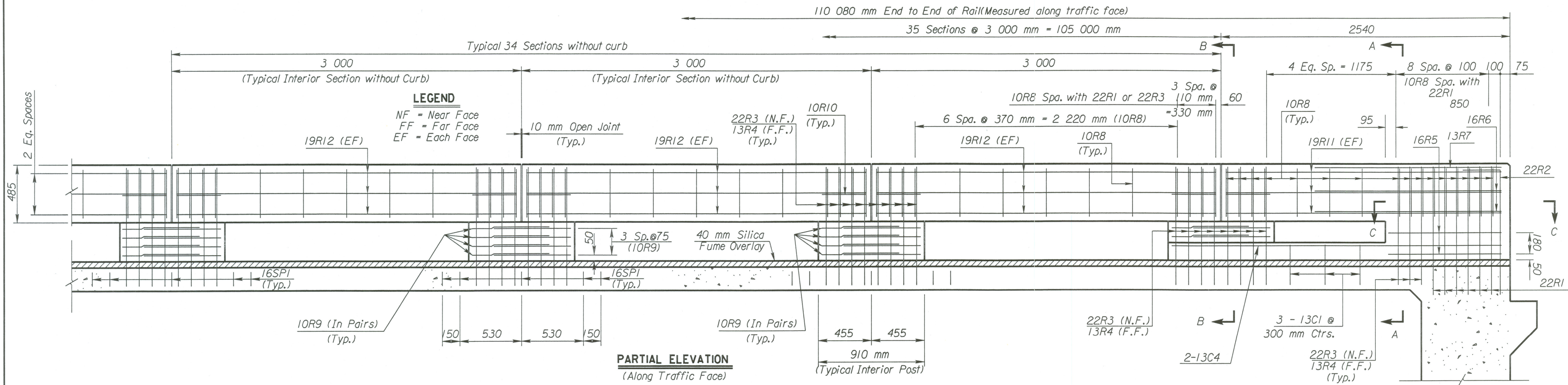

Plotted By : srb
 Plot File : i:\1997\97362\001\bridge\cowskin\EASTBOUND\NorthRail
 Plot Date : 3-27-2002
 Std. Base File :
 Server File : usr2\stand\sl\br182bsi.dgn
 Server : witch
 View = PLOT 1

3				
2				
1	6-14-96	Current Release		
NO.	DATE	REVISIONS	BY	APP'D

CITY OF WICHITA
 Br. No. 54-87-19.29(492)F.E.B. Sta. 16+005.740
 815 mm KANSAS CORRAL RAIL
 EB Frontage Rd. North Rail
 Sedgwick Co.

SHEET NO.	OF	SCALE	APP'D
DESIGNED	QUANTITIES	DESIGNED	CADD
DESIGN CK.	DETAIL CK.	QUAN. CK.	CADD CK.