

**BENCHMARKS:**  
 C.O.W. Disc SE Corner West St. & 47th S.  
 Elev. = 92.29 (City Datum)

RR Spike in N. face of power pole, SE Corner 47th So. & Kessler  
 Elev. = 91.74 (City Datum)

"□" Cut in Top of Curb Adjacent to the NW Corner Lot 27, Block C.  
 Elev. = 93.57 (City Datum)

ANGEL FIRE ADDITION

Contractor to remove trees. Cost of tree removal to be incidental to "Site Clearing and Restoration."

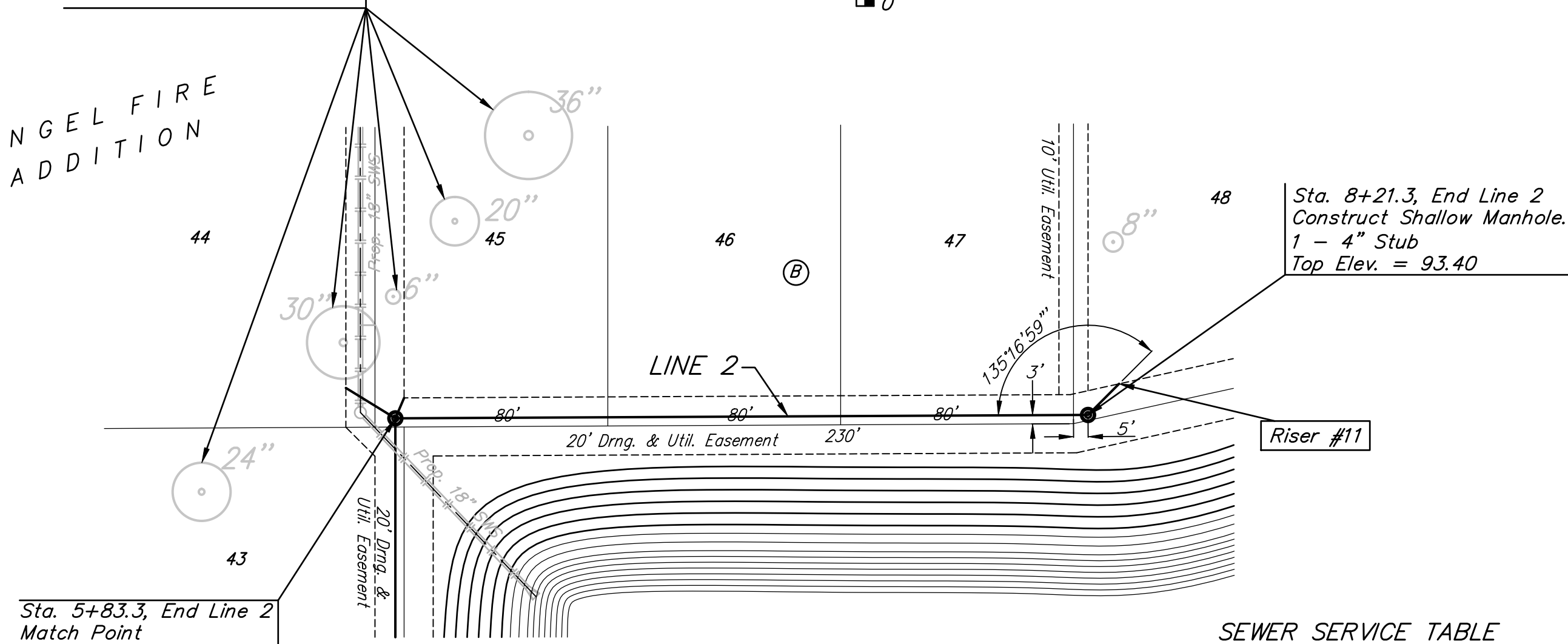
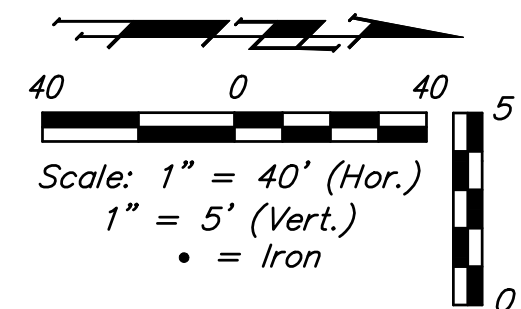

SEWER SERVICE TABLE

NUMBER	TYPE	LOCATION				FOR INFORMATION ONLY	
		LOT NO.	BLOCK	LINE NO.	STATION \ DIRECTION	APPROXIMATE LENGTH 4" PIPE	VERTICAL
11	4" Stub	48	B	2	8+21.3 \ Lt.	1.6'	15'
12	4" Stub	42	C	2A	0+00 \ Lt.	3.2'	16'
13	8"x4" Tee	43	C	2A	0+85.1 \ Lt.	3.9'	8'
14	4" Stub	44	C	2A	2+20.8 \ Lt.	3.9'	17'
15	4" Stub	45	C	2A	2+20.8 \ Lt.	3.9'	9'

NOTE: Vertical Riser Pipe shall be extended to 2' minimum above ground water elevation and 4' maximum below proposed ground elevation. Contractor shall use Method "B" for riser construction. Pipe shall be laid at 2% slope. See detail, sheet 13.

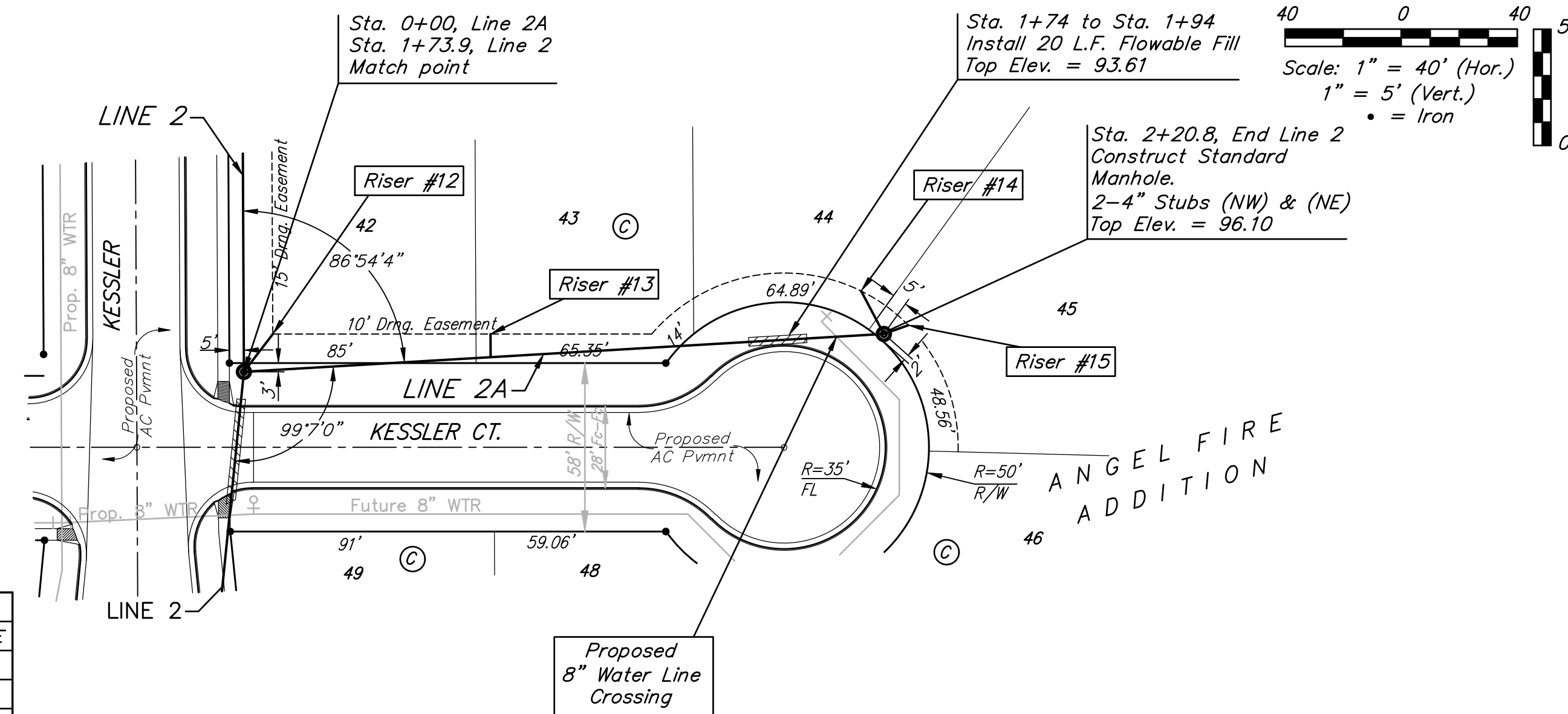

All trench and manhole excavation areas from Sta. 0+00 to Sta. 2+20.8, Line 2A shall be backfilled with sand. The sand backfill shall be within two feet of existing grade and shall be water-jetted and vibrated during backfilling. All costs shall be subsidiary to pipe cost.

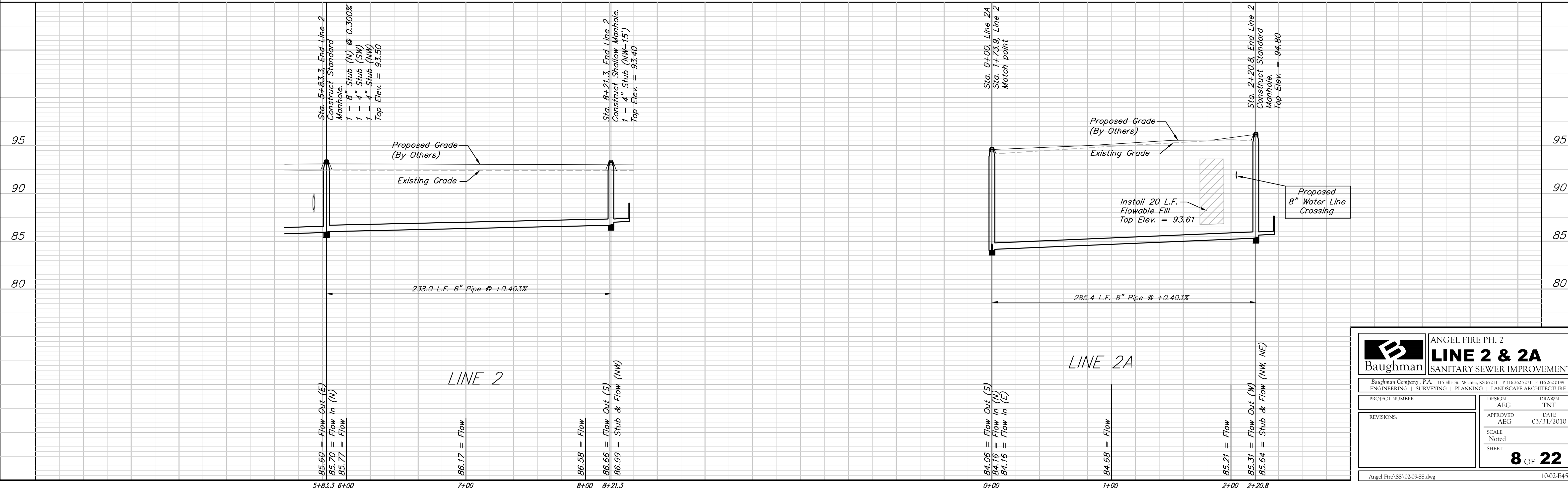

**Baughman** ANGEL FIRE PH. 2  
**LINE 2 & 2A**  
 SANITARY SEWER IMPROVEMENTS

Baughman Company, P.A. 315 Ellis St. Wichita, KS 67211 P 316-262-7271 F 316-262-0149  
 ENGINEERING | SURVEYING | PLANNING | LANDSCAPE ARCHITECTURE

PROJECT NUMBER	DESIGN	DRAWN
REVISIONS:	AEG	TNT
	APPROVED	DATE
	AEG	03/31/2010
	SCALE	Noted
	SHEET	8 OF 22

Angel Fire \SS\02-09-SS.dwg 10-02-E454