

J:\2008Proj\08327\DWG\Structural\DWG\Pump Discharge Piping.dwg C14 Pump P-3 & P-4 & P-5 3/11/2010 - 8:02am Martin

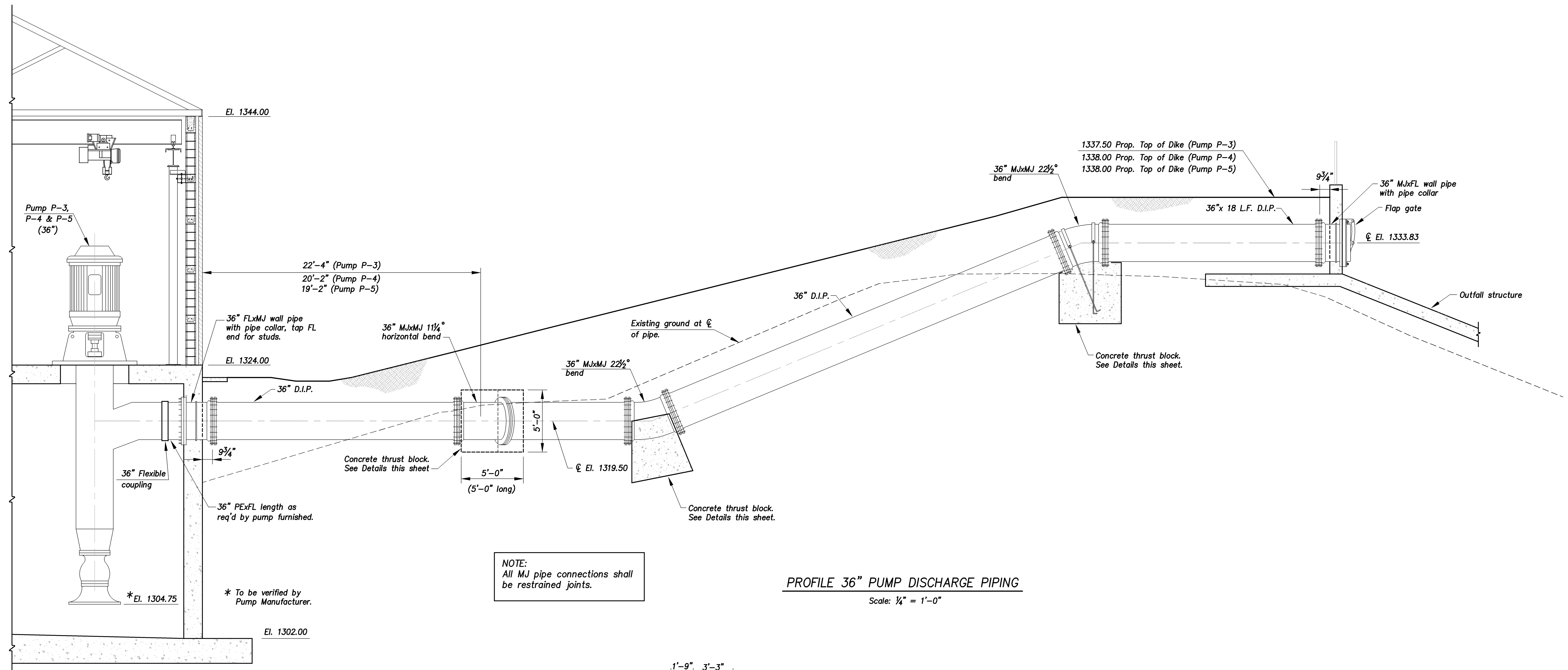

NOTE:
 All MJ pipe connections shall be restrained joints.

PROFILE 36" PUMP DISCHARGE PIPING
 Scale: 1/4" = 1'-0"

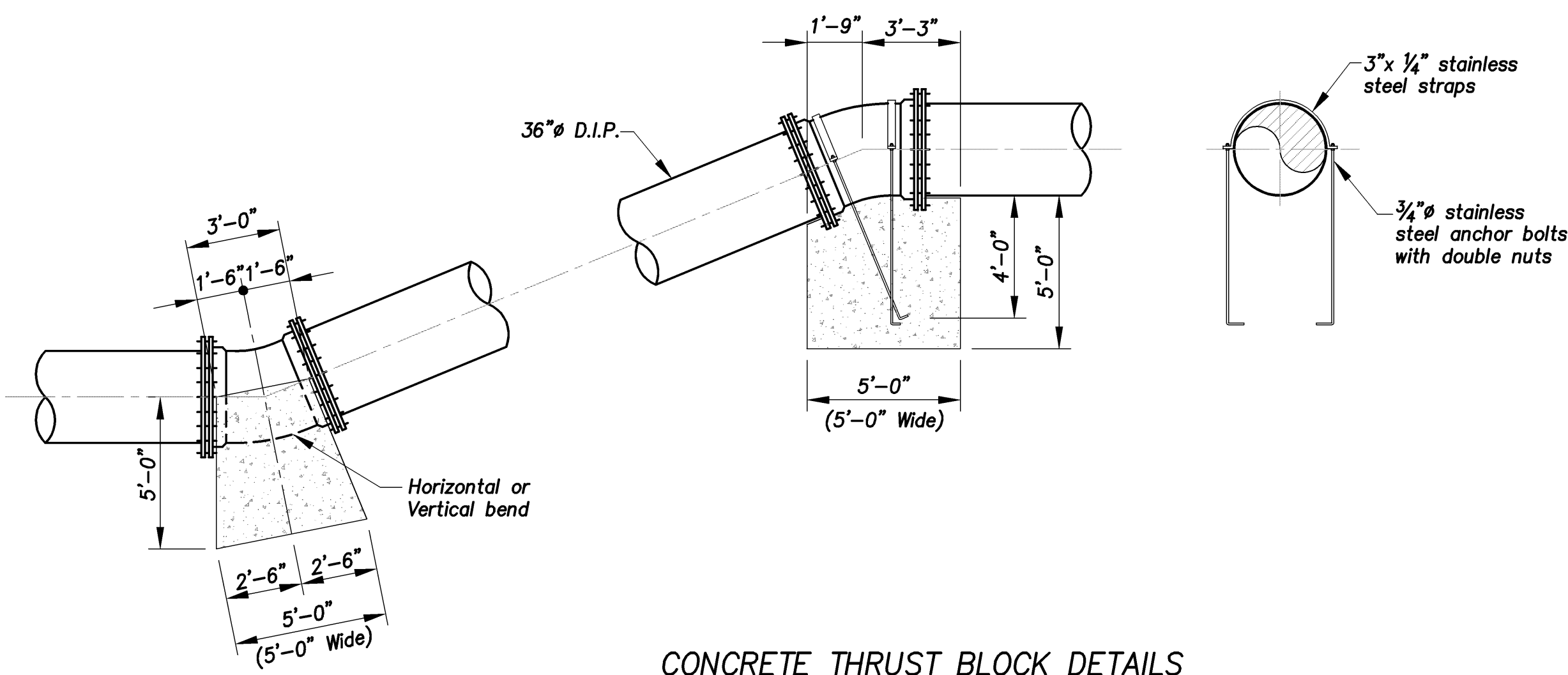

CONCRETE THRUST BLOCK DETAILS
 Scale: 1/4" = 1'-0"

CITY OF WICHITA, KANSAS		CFS Cook, Flatt & Strobel ENGINEERS, P. A.
PUMP STATION NO. 11		
STRUCTURAL		DESIGNED MDC
36" PUMP DISCHARGE PIPING		SCALE As Shown
		DATE 3-10-2010
		CHECKED HAP
		SHEET C14 OF C31