

POWER POLE DETAILS

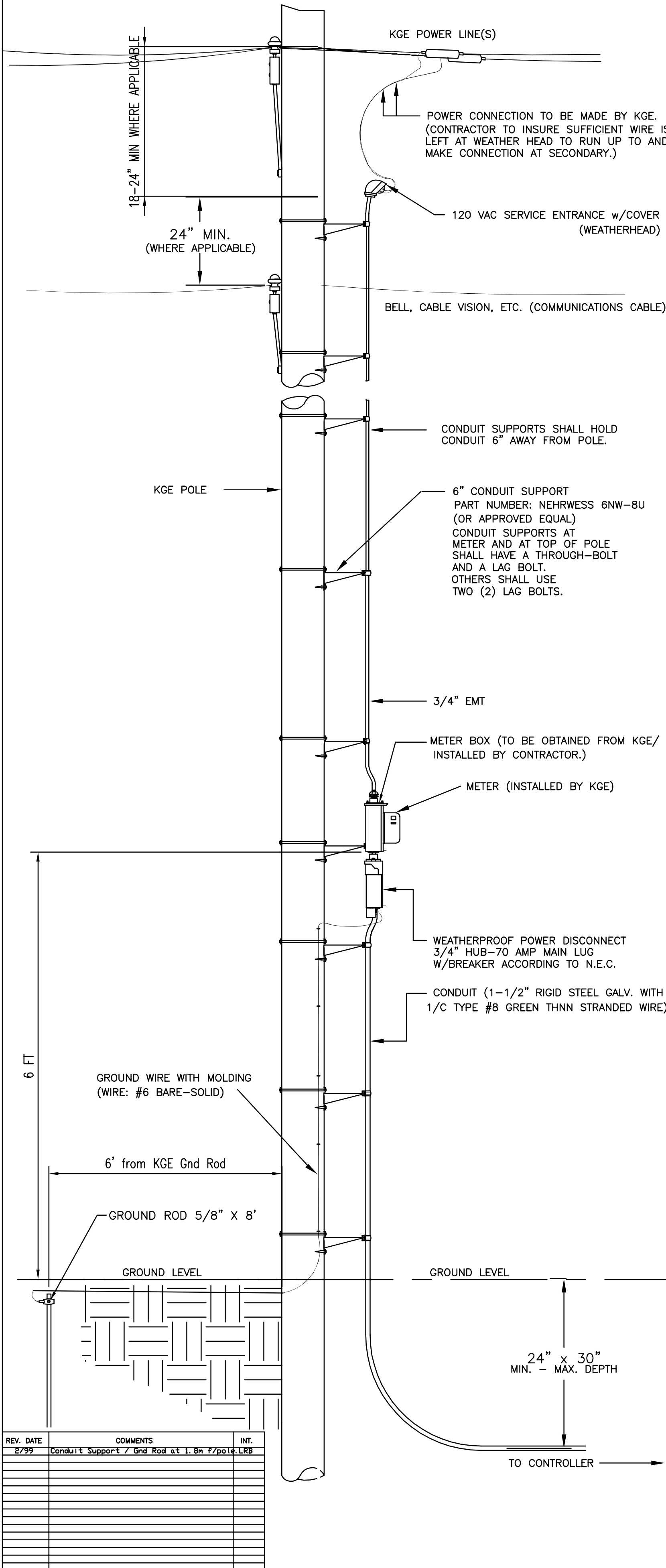

SPANWIRE ASSEMBLY DETAILS

1. MAX. SAG = 5% OF SPAN.
2. STANDARD BACKRAKE = 1.5'
3. HEIGHT OF STRAIN WIRE HOOK-UP TO BE DETERMINED BY FIELD ENGINEER. TRAFFIC SIGNAL CABLE TO BE SECURED TO STRAIN (SPAN) WIRE WEATHERABLE NYLON CABLE HANGERS (12" CTR.) DETAIL 'B'
4. TETHER CLAMP TO BE DESIGNED TO RELEASE UNDER 'HIGH WIND LOAD' TO PERMIT SIGNAL 'FREE SWING'.

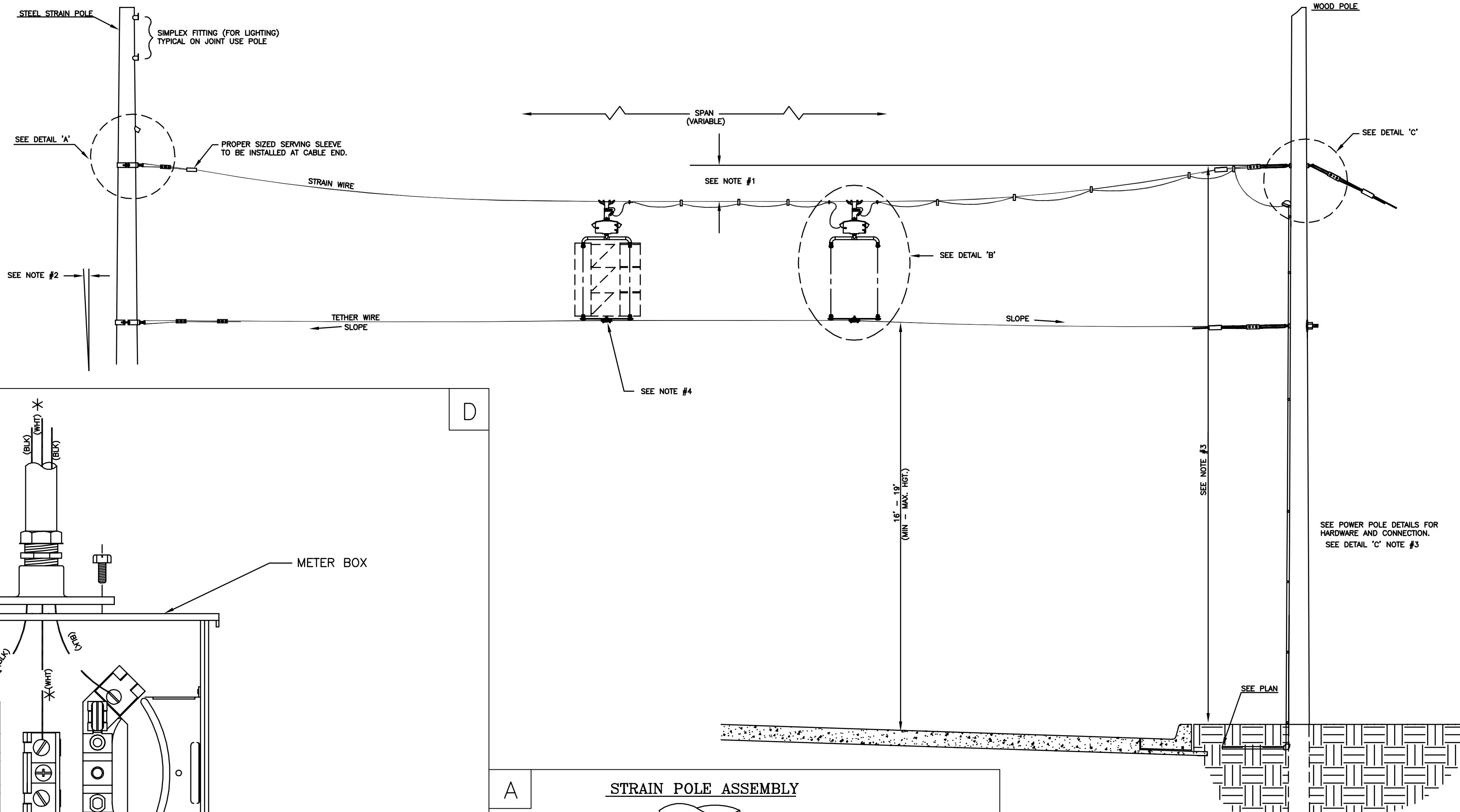

METER BOX & POWER DISCONNECT DETAILS

NOTE:
* TO BE MARKED WITH WHITE TAPE

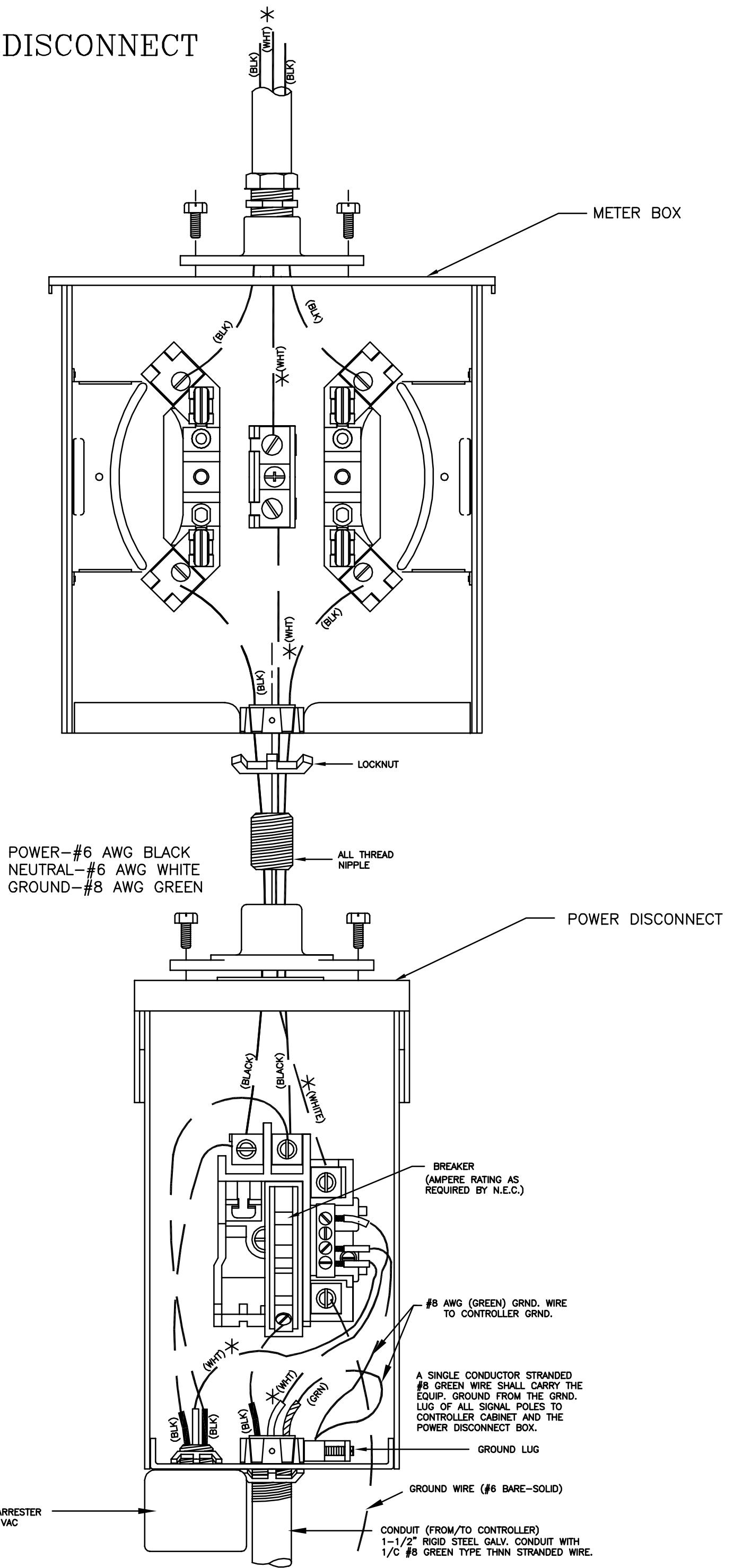

A STRAIN POLE ASSEMBLY

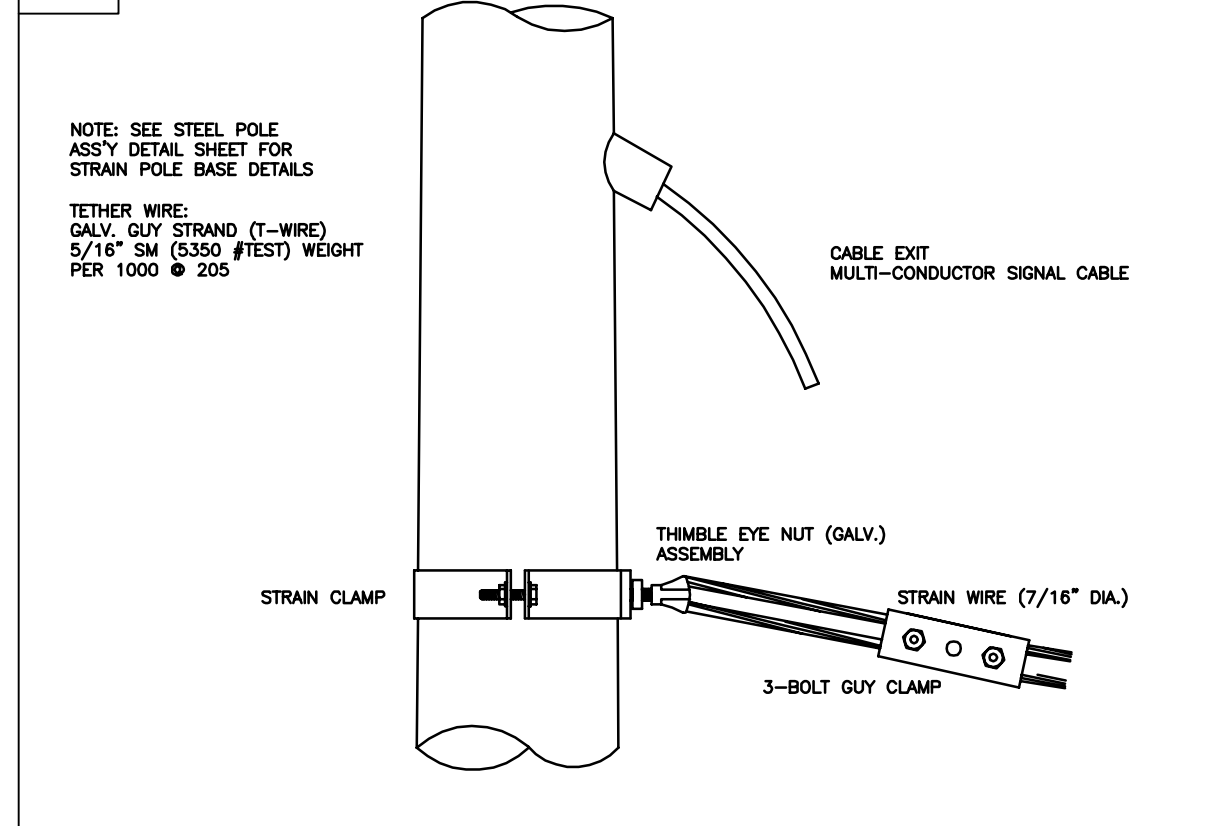

B SIGNAL BRACKET ASSEMBLY DETAILS

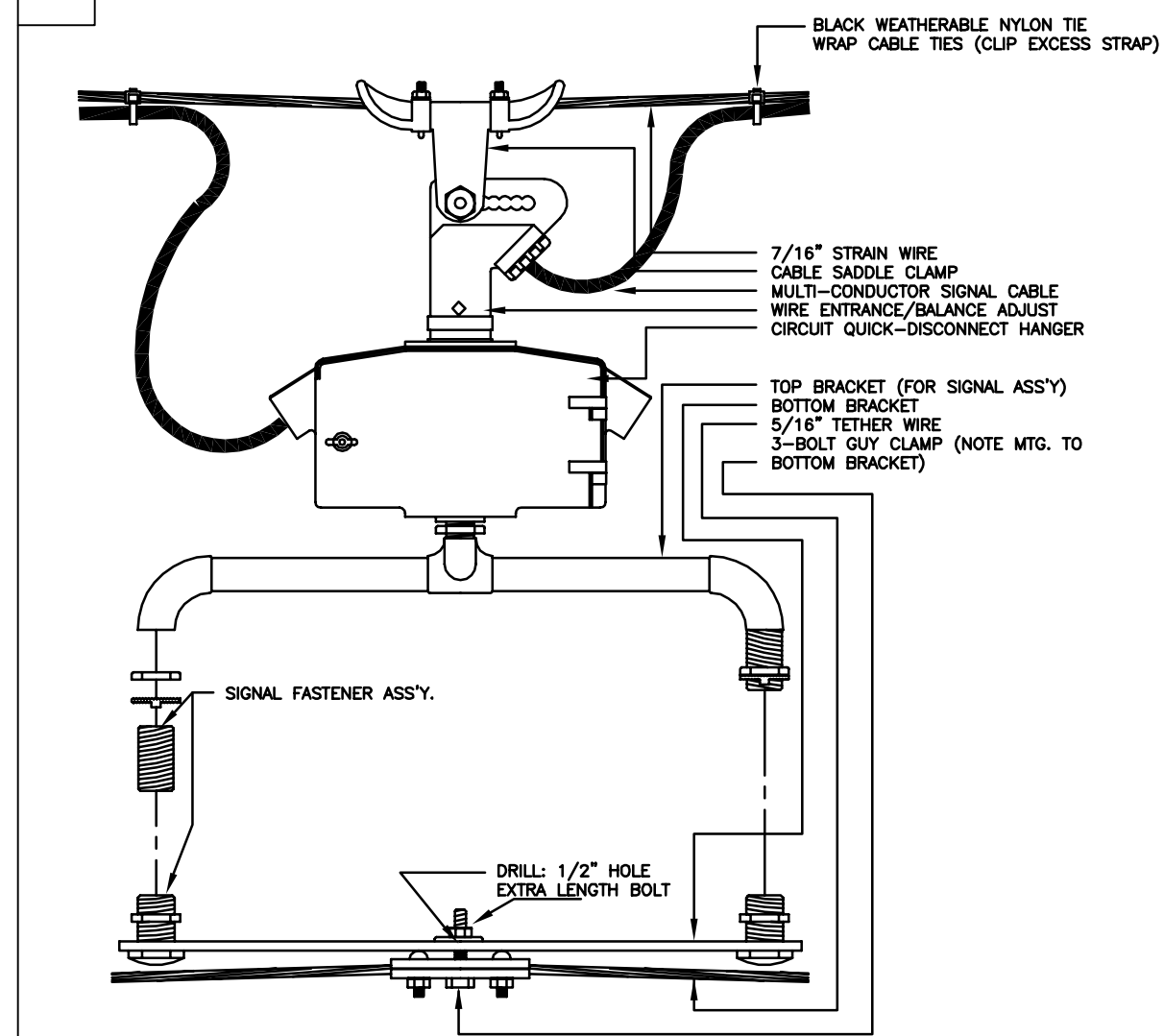

C WOOD POLE ASSEMBLY DETAILS KGE POLE EXCLUDED

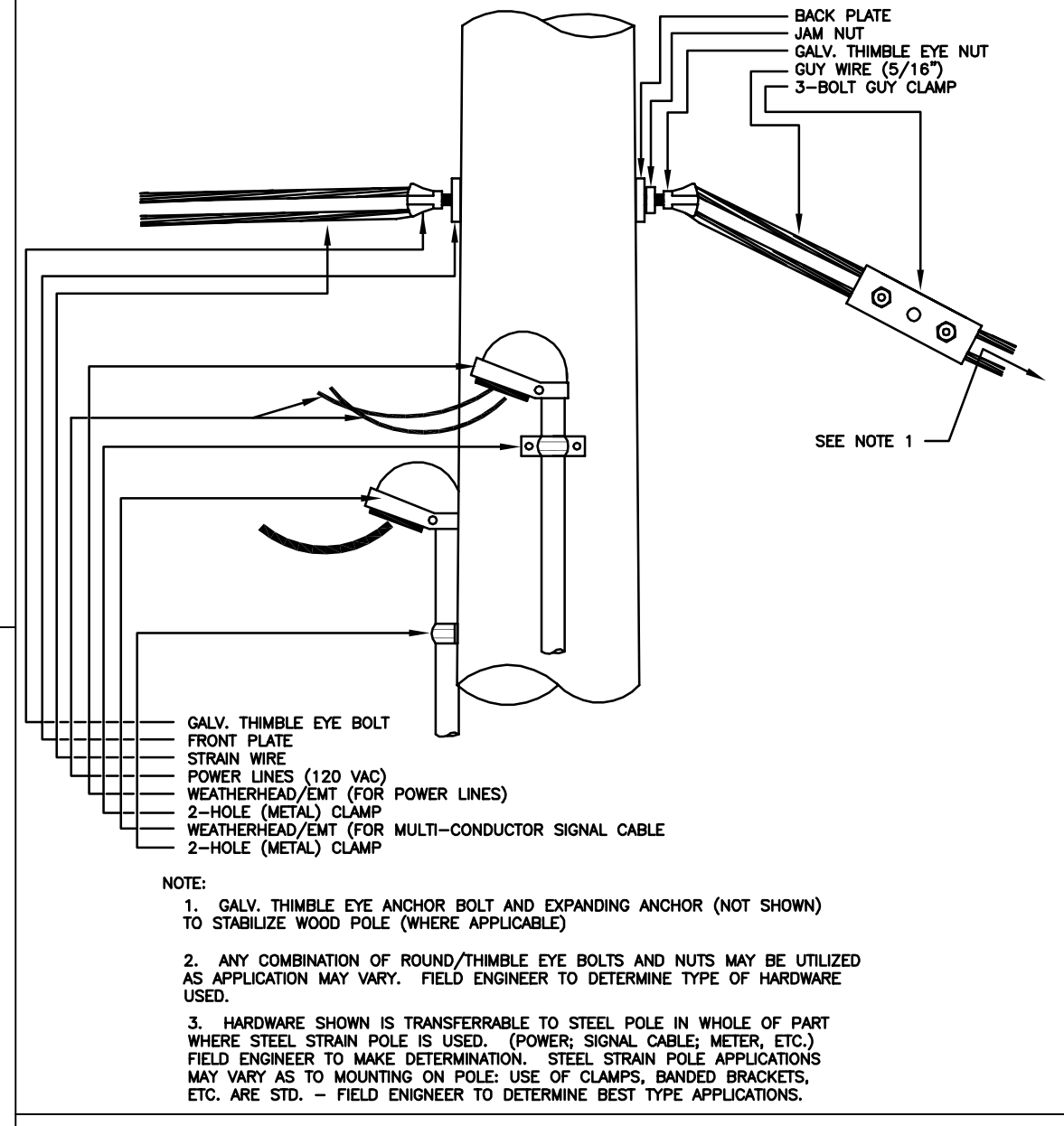

PROJECT DESCRIPTION		
POWER POLE AND SPAN POLE ASSEMBLY DETAILS		
PROJECT NUMBER		
DRAWN BY: T.M.	APPROVED BY:	REVISED BY: L. B.
DATE: FEB. 96		DATE: 2/26/99
CITY OF WICHITA DEPARTMENT OF PUBLIC WORKS		
DIVISION OF TRAFFIC ENGINEERING	SCALE	
RANDALL W. HOSKINS, P.E. TRAFFIC ENGINEER	NO SCALE	

DSNR: BER OPER: SDM SCALE: 1=1.00
 Q: 2004/04/28 Power Pole Detail 08-31-2004 10:58:42 am