

FHWA REG. NO.	STATE	PROJECT NO.	YEAR	SHEET NUMBER	TOTAL SHEETS
7	KANSAS	87N-0211-01	2000	26	44

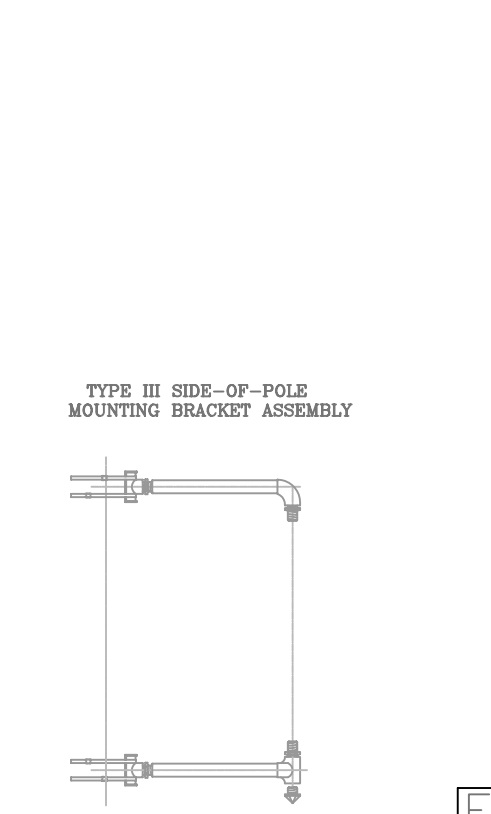
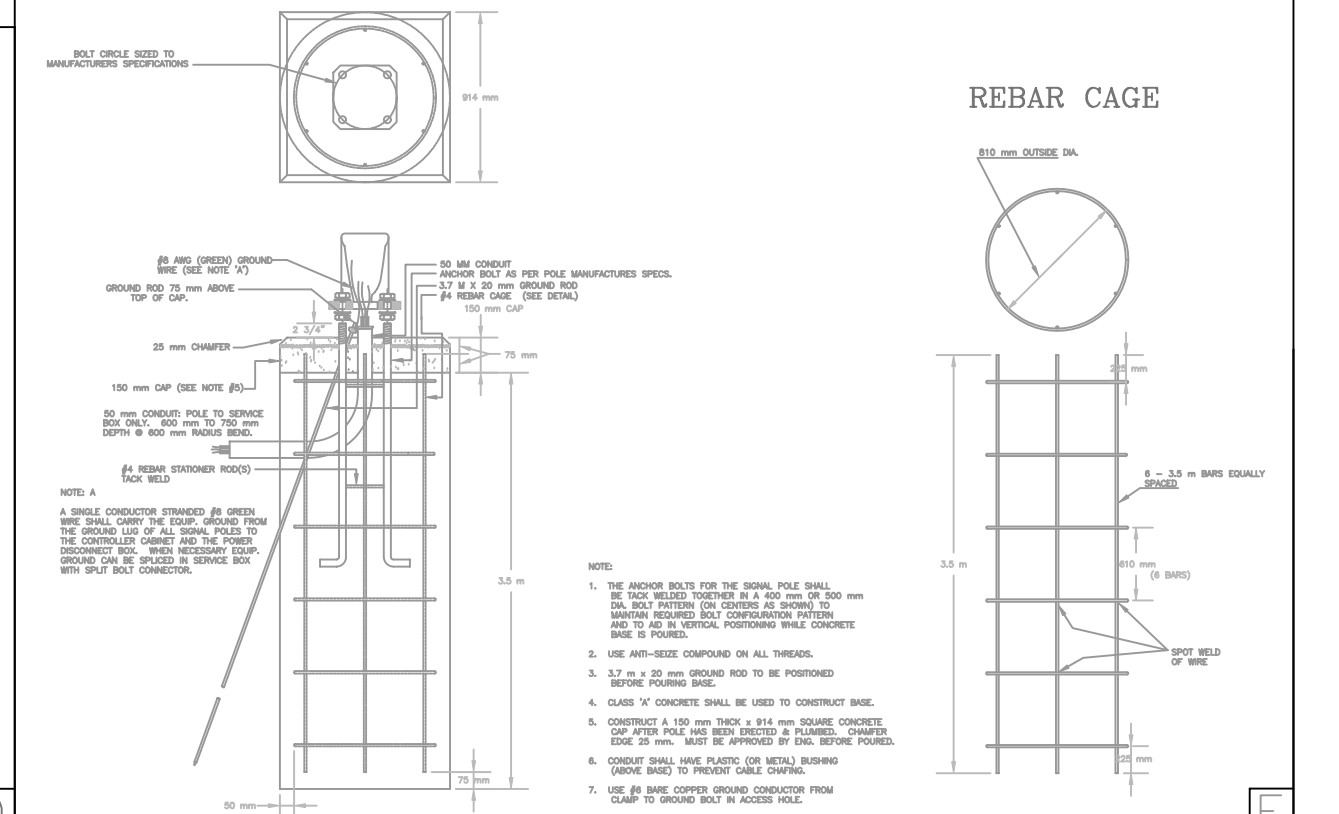
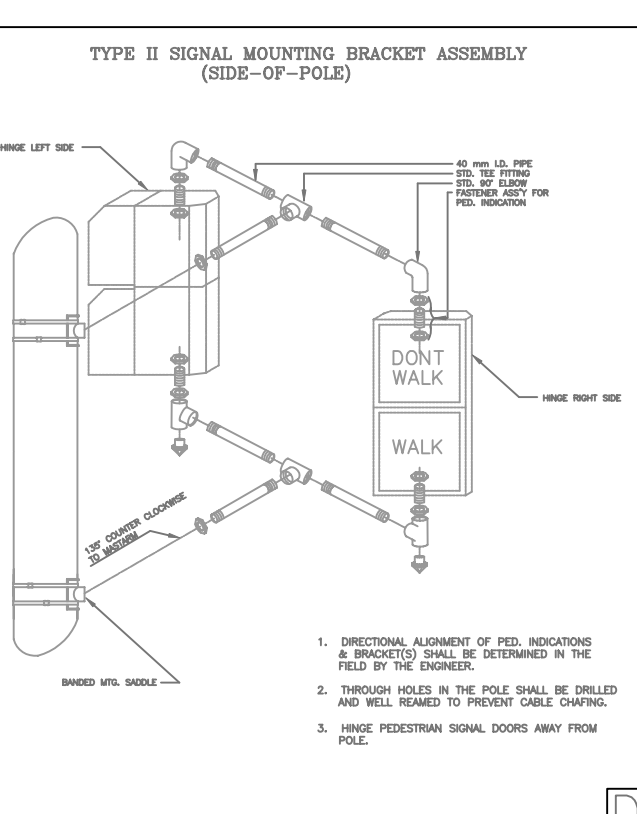
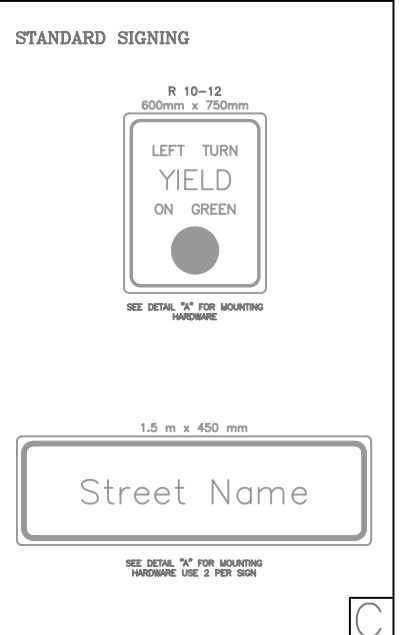
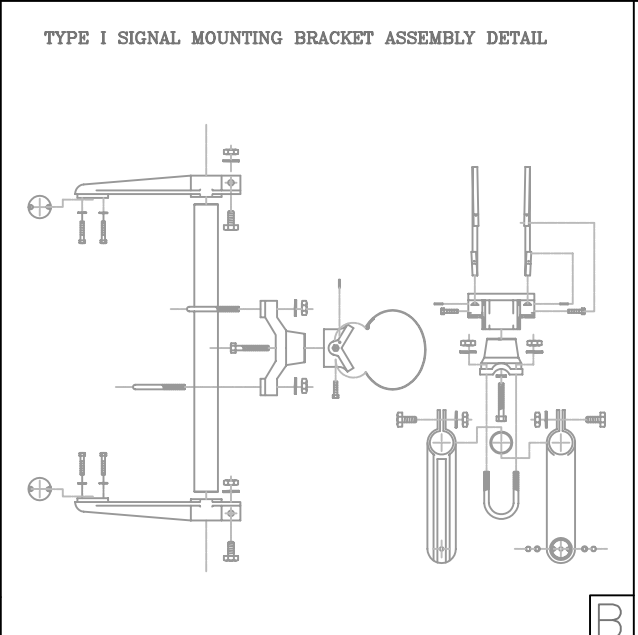
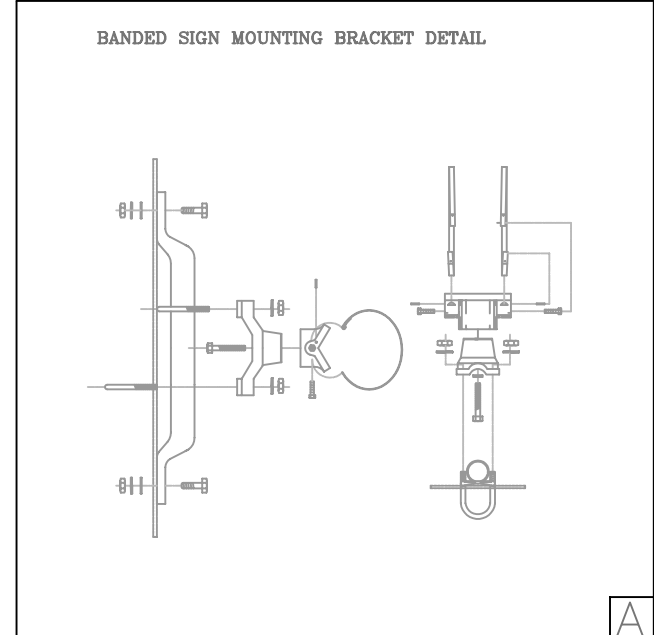
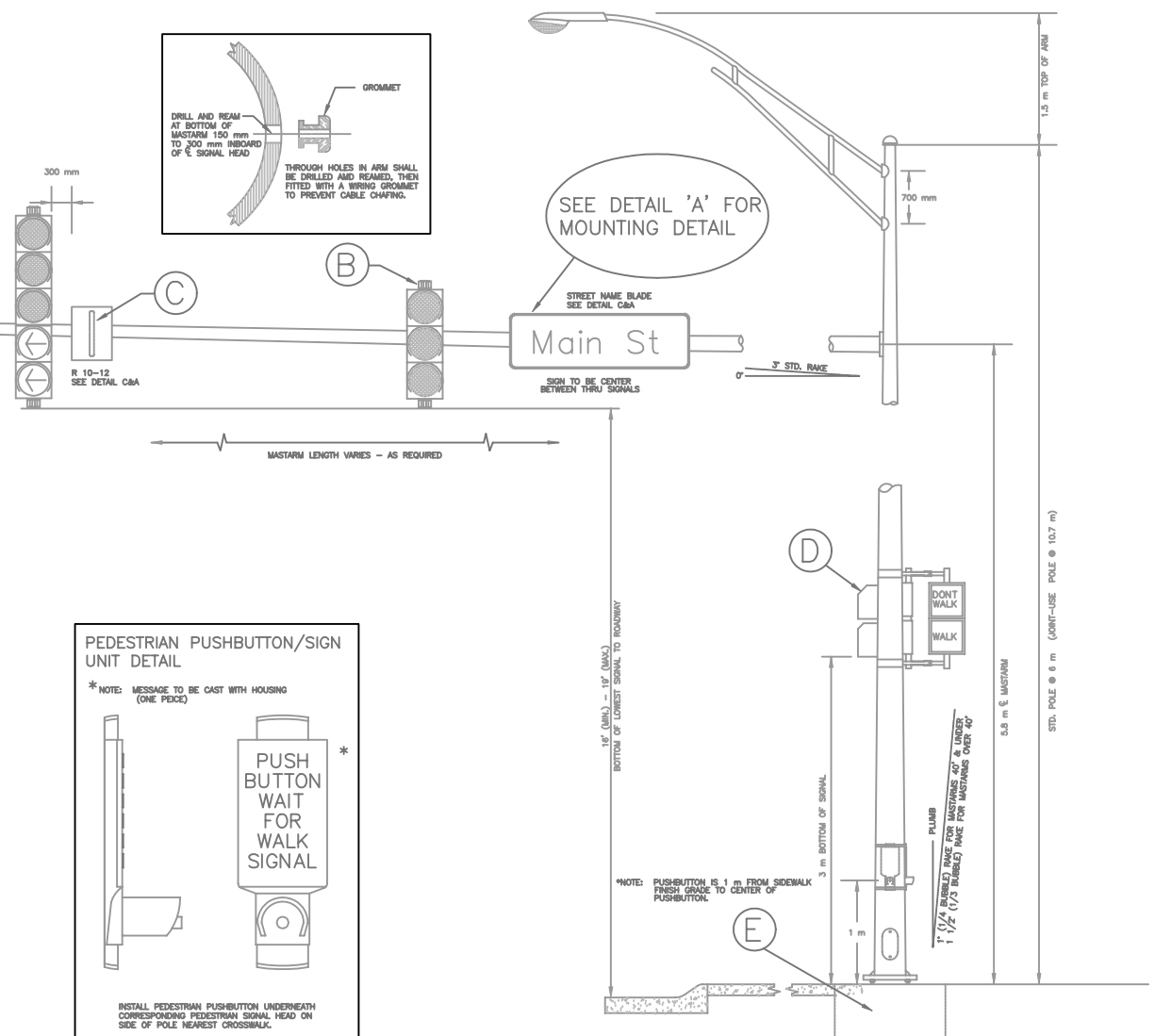

PROJECT DESCRIPTION		
STEEL SIGNAL POLE ASSEMBLY DETAILS		
PROJECT NUMBER 111 PPP (607879)		
DRAWN BY: T.M.	SCALE NO SCALE	REVISED BY: T.M.
DATE: FEB. 96		DATE: MAY, 97
CITY OF WICHITA DEPARTMENT OF PUBLIC WORKS		
DIVISION OF TRAFFIC ENGINEERING K. WOODARD, P.E. TRAFFIC ENGINEER		SHEET 11 OF 21