

**EXPANSION JOINT**

NOTE: Extra Thickness to be Subsidiary to Price of Square Yards Pavement

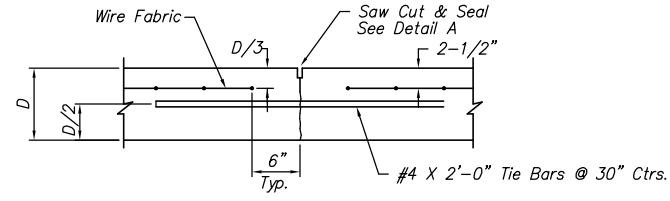

**LONGITUDINAL JOINT DETAIL (L.J.)**

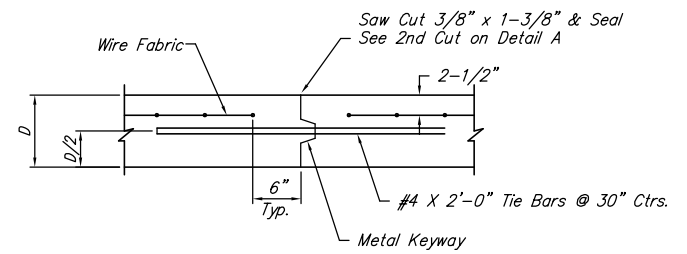

**OPTIONAL LONGITUDINAL JOINT DETAIL (L.J.)**

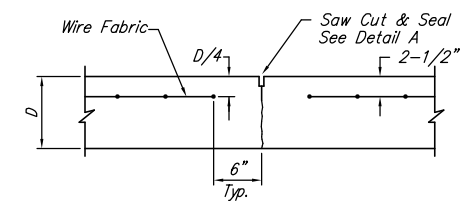

**CONTRACTION JOINT DETAIL (C.J.)**

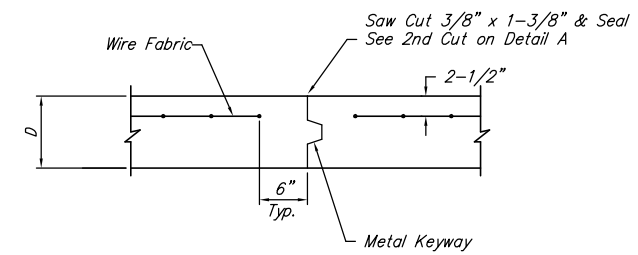

**OPTIONAL CONTRACTION JOINT**

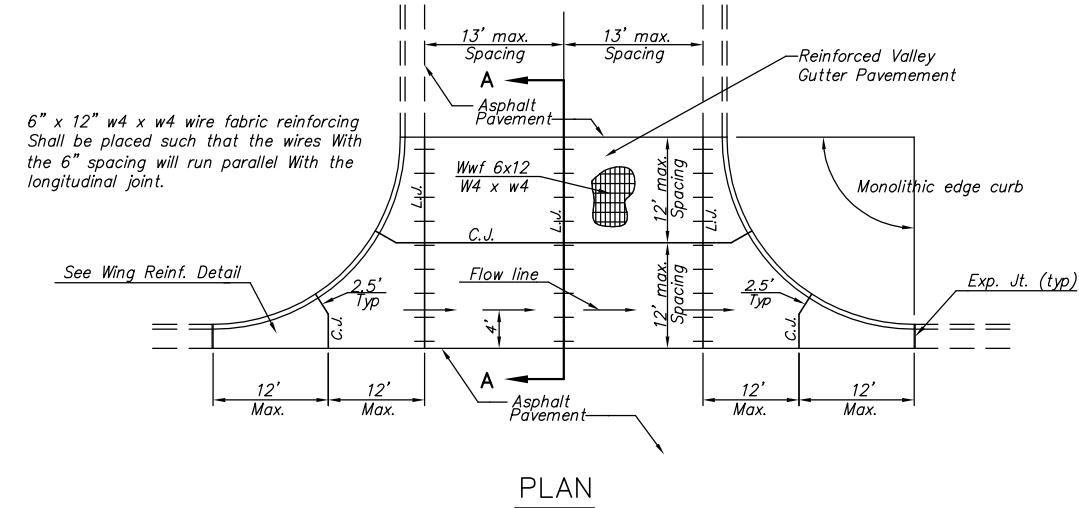

**REINFORCED VALLEY GUTTER DETAIL**

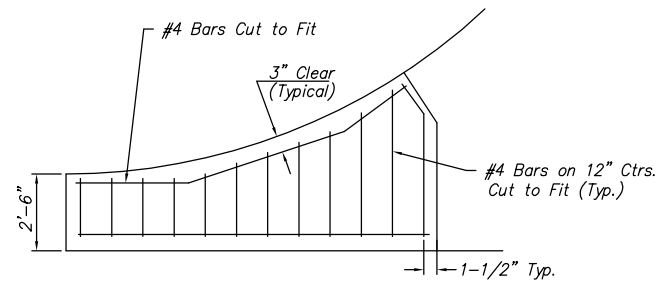

**WING REINFORCING DETAIL**

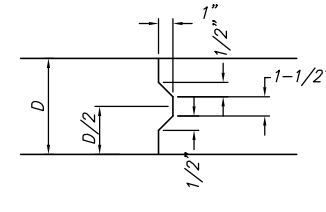

**KEYWAY DETAIL**

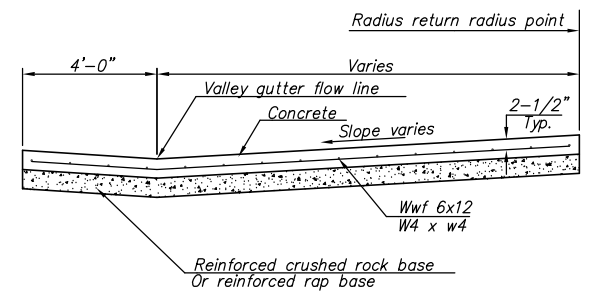

**SECTION A-A**

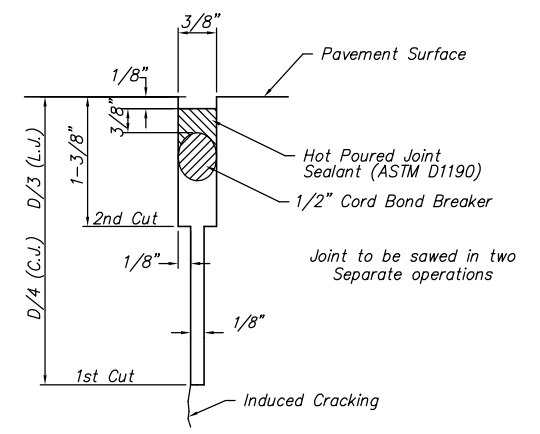

**SAW JOINT DETAIL**

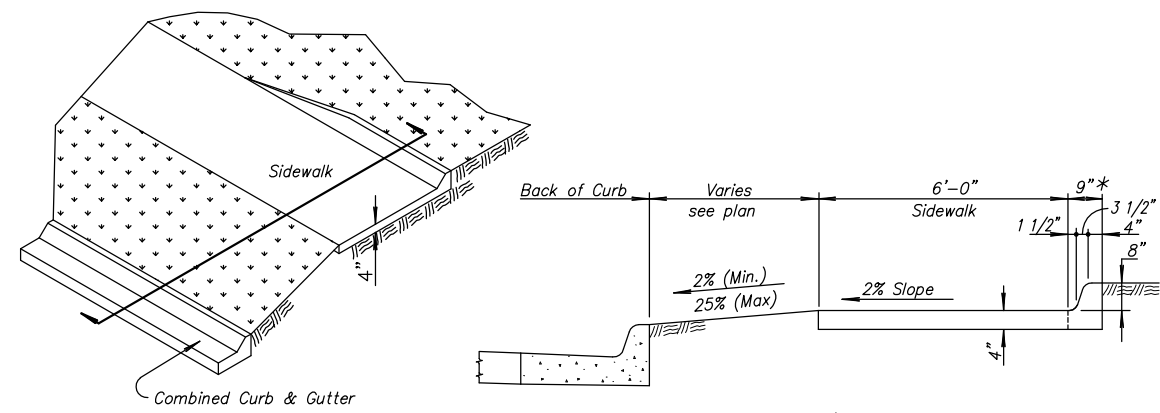

**PLAN**

**SECTION**

**SIDEWALK (SPECIAL)**

Note: Sidewalk (Special) shall be constructed at locations shown on plans.

J:\Civil\03431\dwg\Details\03431ed2.dwg 2/4/2005 11:17:12 AM CST

<p>THE CITY OF WICHITA</p> <p>CITY ENGINEER'S OFFICE CITY HALL - SEVENTH FLOOR 455 NORTH MAIN STREET WICHITA, KANSAS 67202 (316) 268-4501 (316) 268-4114 FAX</p>	<b>VALLEY GUTTER AND SPECIAL SIDEWALK DETAILS</b>	
	JIM ARMOUR, P.E. - CITY ENGINEER	
	PROJECT NUMBER 472-83855	OCA NUMBER
	DATE JUL 03	SHEET 11 OF 37