

STATE	PROJECT NO.	YEAR	SHEET NO.	TOTAL SHEETS
KANSAS			25	106

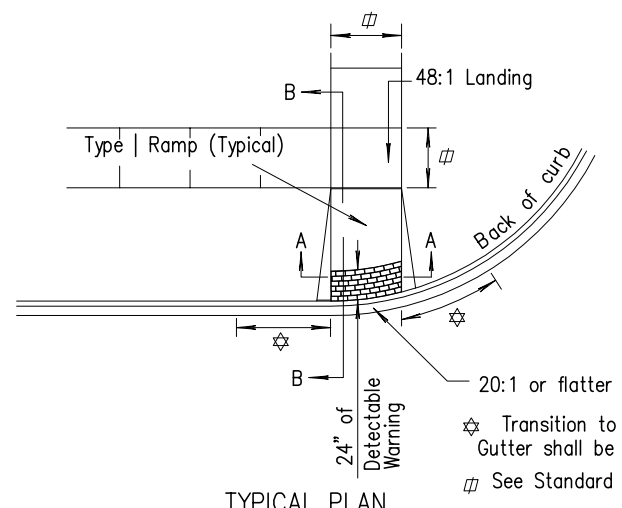

TYPICAL PLAN

☆ Transition to normal curb and gutter section. Gutter shall be shaped to provide positive drainage.
 ▣ See Standard Drawing No. RD725 for additional details.

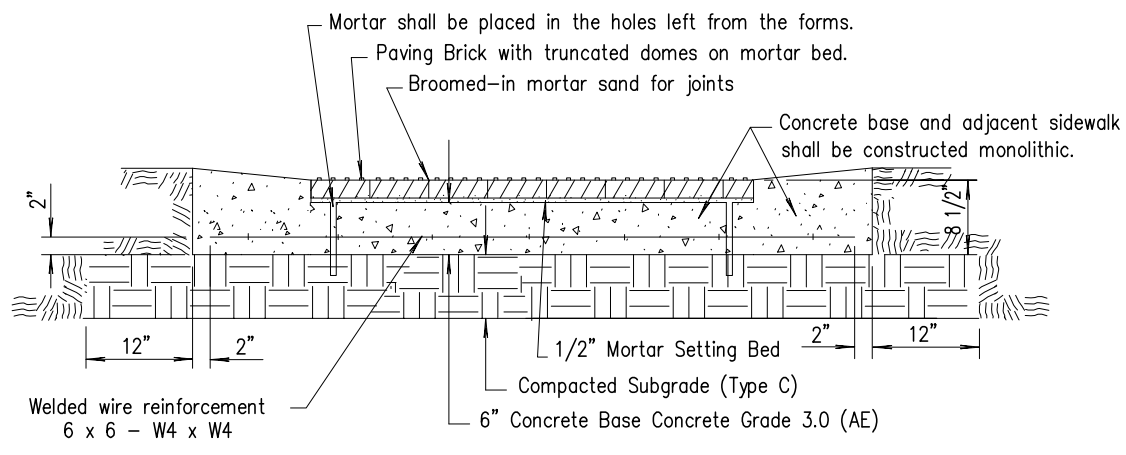

TYPICAL SECTION OF PAVER BRICK SECTION A-A

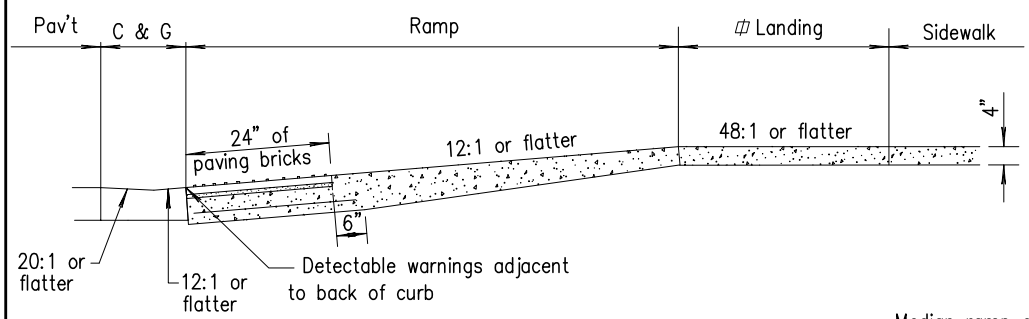

SECTION B-B

⊗ Median ramp crossing limits will be paid for as "Sidewalk Ramp."

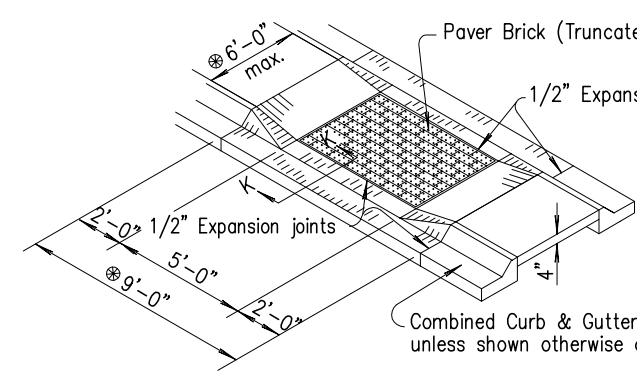

NARROW MEDIAN RAMP CROSSING

Note: A Median Ramp Crossing shall be constructed at Crosswalk locations.

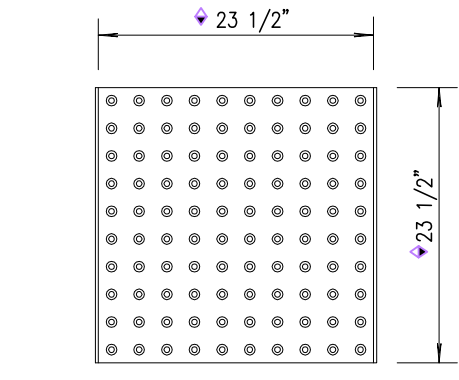

PRESTRESSED RAMP PANEL with TRUNCATED DOME SURFACE

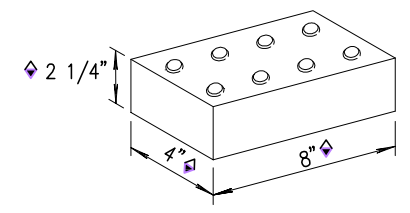

PAVER BRICK WITH TRUNCATED DOME SURFACE

◆ These dimensions are nominal.

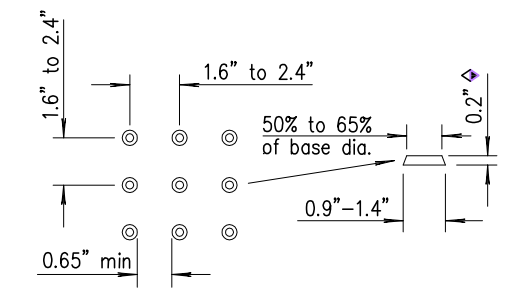

TRUNCATED DOME DIMENSIONS for SQUARE PATTERN (Parallel Alignment)

ψ Either product is acceptable with no mixing of types within an installation.

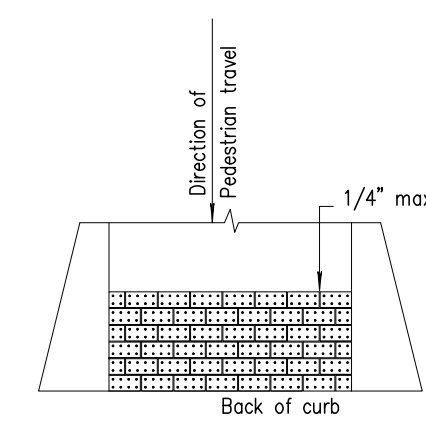

STRAIGHT CURB DETAILS

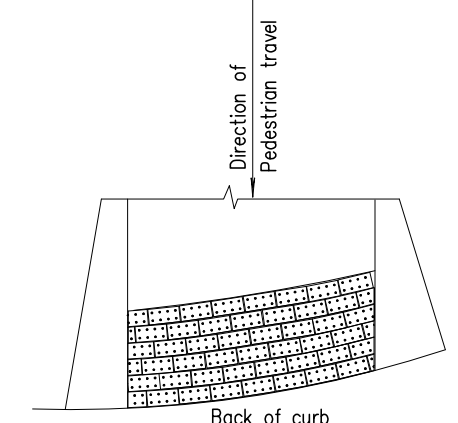

RADIUS CURB DETAILS

■ The installation pattern shown for the detectable warning paving bricks is running bond. Other patterns may be used upon the approval of the Engineer. The truncated domes on the bricks shall be placed in a parallel alignment for the direction of pedestrian travel as shown. The running bond pattern may be rotated 90 degrees to reduce the spacing between the bricks for radius installations. The spacing between bricks for radius curb installations may vary for each site. This spacing shall be kept to a minimum upon review and approval of the Engineer.

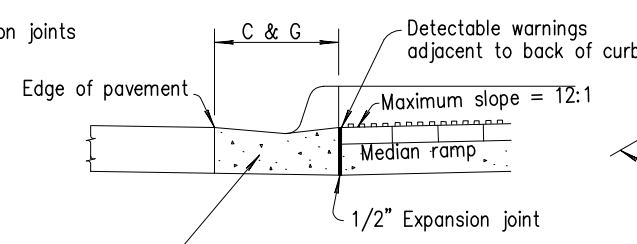

SECTION K-K

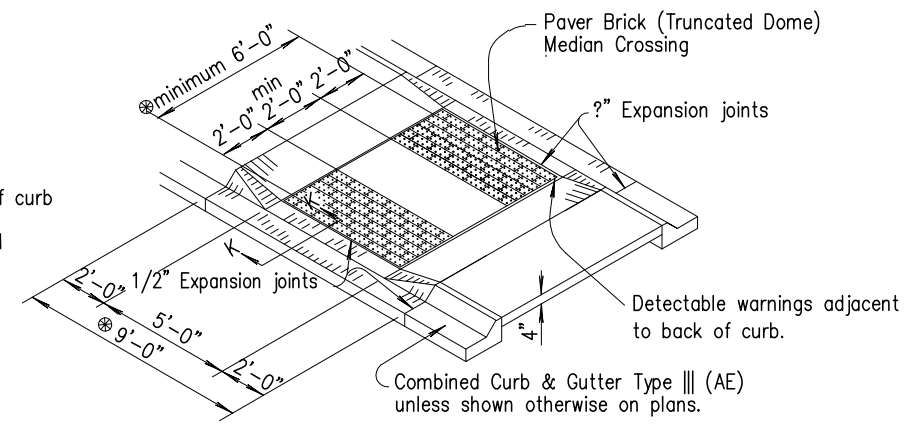

WIDE MEDIAN RAMP CROSSING

Note: A Median Ramp Crossing shall be constructed at Crosswalk locations. Wider median islands will result in a 2' minimum gap between the truncated dome areas.

GENERAL NOTES
 The details depicted here may not be appropriate for all locations. Designs shall meet this criteria on all new construction projects unless impracticable by site restrictions. For an existing sidewalk facility where the sidewalk will be replaced, this sidewalk will be replaced according to this drawing to the maximum extent feasible.
 Paving Brick/Prestressed Panel (Truncated Dome Surface) units shall meet the requirements of the standard specifications.
 The bricks/panels shall be placed in a pattern that conforms to this drawing and aligned in the direction of pedestrian travel.
 The bricks/panels shall have a truncated dome top surface for detectable warning to pedestrians and comply with the American Disabilities Act.
 The truncated dome surface shall cover the width of the ramp and extend a length of 24" as shown on this drawing and standard drawing RD725.
 The truncated dome surface shall be a contrasting color to the adjacent surfaces.
 The bricks/panels shall be saw cut only and any brick/panel shall not be less than 25% of a full brick/panel.
 The mortar setting bed and joint mortar sand for the paving brick option shall meet the requirements in the standard specifications. The prestressed panel option does not require the mortar bed or mortar sand. The panels shall be placed in fresh concrete in accordance to the standard specifications.
 The entire ramp or median crossing as shown will be bid as "Sidewalk Ramp" and payment for this work will be measured by the square yard.
 All materials and labor to install the sidewalk ramp shall be subsidiary to the bid item "Sidewalk Ramp."

NO.	DATE	REVISIONS	BY	APP'D
3	8-15-05	Added Prestressed Ramp Panel alt.	S.W.K.	J.O.B.
2	2-24-05	Class to Grade conc., wire reinf.	S.W.K.	J.O.B.
1	8-20-03	Revised details and notes	S.W.K.	J.O.B.

KANSAS DEPARTMENT OF TRANSPORTATION

AUXILIARY DETAILS FOR SIDEWALK & STEPS

RD725A

DESIGNED	1-1-04-05	APP'D	James O. Brewer
TRACED		QUANTITIES	TRACED
DESIGN CK.		DETAIL CK.	QUAN. CK.
			TRACE CK. King