

MANHOLE RING AND COVER

*See City of Wichita Standard Manhole Ring and Cover Detail Sheet for Cover Details to Be Used With Inlet Frame.

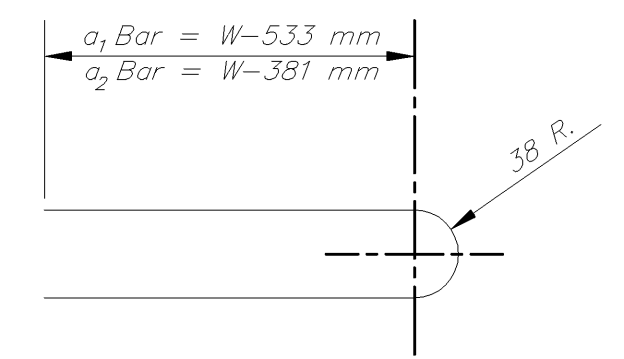

BENDING DIAGM

STEEL SCHEDULE

BAR NUMBER	a ₁	a ₂	a ₃	b ₁					b ₂	b ₃	b ₄	Wt. Kg.
				#=1321 m	#=1625 m	#=1930 m	#=2235 m	#=2540 m				
SIZE	#13	#13	#13	#13	#13	#13	#13	#13	#13	#13	#19	
LENGTH	W=1.321 m	1.700 m	2.000 m	1.220 m	1.850 m	-	-	-	530 mm	1.880 m	1.420 m	27.2±
	W=1.625 m	2.310 m	2.610 m	1.520 m	1.850 m	-	-	-	530 mm	1.880 m	1.420 m	36.7±
	W=1.930 m	2.920 m	3.220 m	1.830 m	-	1.850 m	-	-	530 mm	1.880 m	1.420 m	45.8±
	W=2.235 m	3.530 m	3.830 m	2.130 m	-	-	1.850 m	-	530 mm	1.880 m	1.420 m	54.9±
	W=2.540 m	4.140 m	4.440 m	2.440 m	-	-	-	1.850 m	530 mm	1.880 m	1.420 m	64.0±

Note: a₃ Bars to be Placed Approx. 50 mm Below Top of Inlet Cover.

STANDARD CURB INLET PRECAST TOPS			
W	PRE-CAST TOP SIZE	PIPE SIZE	cu m Conc.
1.321 m	1.121 m 1.9 m 190 mm	525 mm & SMALLER	0.29±
1.625 m	1.425 m 1.9 m 190 mm	600 mm & 750 mm	0.39±
1.930 m	1.730 m 1.9 m 190 mm	900 mm & 1 050 mm	0.49±
2.235 m	2.035 m 1.9 m 190 mm	1 200 mm & 1 350 mm	0.59±
2.540 m	2.340 m 1.9 m 190 mm	1 500 mm & 1 650 mm	0.69±

GENERAL NOTES

- Concrete tops to be installed on thin mortar cushion to insure full support along brick walls. Concrete tops may be cast in place or precast. Concrete used for inlet construction shall be concrete pavement mix with air entrainment.
- Contractor shall have the option of constructing 200 mm brick masonry walls between the concrete inlet base and top on this inlet when W=1.90 m and H=2.1 m or less.
- Inlet invert shall be shaped with 8 sack sand mix concrete to create flow channels and to increase hydraulic efficiency such that the inlet will be self cleaning between all inlet and/or outlet pipes.
- The ends of all pipes installed in inlets shall be cut off flush with the inside face of the inlet wall.

Note: All dimensions shown without a SI suffix are in millimeters.

STYPI-S.DWG

THE CITY OF WICHITA

CITY ENGINEER'S OFFICE
CITY HALL - SEVENTH FLOOR
455 NORTH MAIN STREET
WICHITA, KANSAS 67202
(316) 268-4501
(316) 268-4114 FAX

STANDARD TYPE 1

CURB INLET

OPENING=150 x 1500 mm

M. E. LINDEBAK P.E. - CITY ENGINEER

PROJECT NUMBER INDEX CODE

DATE SHEET 20 OF 54