

PRECAST SLAB AND FLOOR REINFORCING

MARK	SIZE	W = 1,321 m		W = 1,625 m		W = 1,930 m		W = 2,235 m		W = 2,540 m	
		NO.	LENGTH	NO.	LENGTH	NO.	LENGTH	NO.	LENGTH	NO.	LENGTH
* a1	#13	13	2,007 m	13	2,616 m	13	3,226 m	13	3,835 m	13	4,445 m
a2	#13	4	1,829 m	4	2,438 m	4	3,048 m	4	3,658 m	4	4,267 m
a3	#13	23	1,244 m	23	1,549 m	23	1,854 m	23	2,159 m	23	2,464 m
b1	#13	1	2,972 m	1	2,972 m	1	2,972 m	1	2,972 m	1	2,972 m
* b2	#13	23	3,324 m	29	3,324 m	35	3,324 m	41	3,324 m	47	3,324 m
x1	#13	16	1,168 m	16	1,270 m	16	1,372 m	16	1,473 m	16	1,575 m

WALL REINFORCING

MARK	SIZE	W = 1,321 m		W = 1,625 m		W = 1,930 m		W = 2,235 m		W = 2,540 m	
		NO.	LENGTH	NO.	LENGTH	NO.	LENGTH	NO.	LENGTH	NO.	LENGTH
w1	#13	①	3,324 m	①	3,324 m	①	3,324 m	①	3,324 m	①	3,324 m
w2	#13	①	1,244 m	①	1,549 m	①	1,854 m	①	2,159 m	①	2,464 m
w3	#13	②		②	56	②	60	②	64	②	68

* Field Bend or Cut Reinforcing as Required for Clearance.
 ① 4 (H - 300) : (H - 300) Rounded down to nearest 150 mm.
 ② H - 75

GENERAL NOTES:

- The contractor shall be required to construct 200 mm brick masonry walls between the concrete inlet base and top on this inlet when W=1,930 m or less and H=2,134 m or less. When W is greater than 1,930 m and H is less than 2,134 m the outside inlet walls below the brick stack shall be reinforced concrete construction and the center wall shall be of masonry construction as shown for the masonry wall option.
- Inlet invert shall be shaped with 8 sack sand mix concrete to create flow channels and to increase hydraulic efficiency such that the inlet will be self cleaning between all inlet and/or outlet pipes.
- Concrete tops to be installed on thin mortar cushion to insure full support along brick walls. Concrete tops may be cast in place or precast. Concrete used for inlet construction shall be concrete pavement mix.
- Inlet top reinforcing shall be spaced on 150 mm max. centers. Inlet lids shall be notched out as indicated to facilitate construction of curb. Bars in inlet top to be field bent or cut to clear manhole ring.
- The ends of all pipes installed in inlets shall be cut off flush with the inside face of the inlet wall.

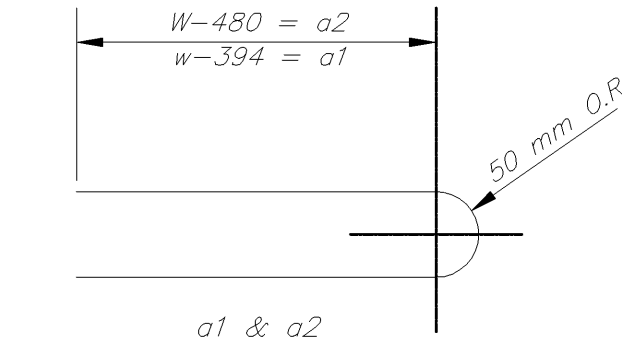

STANDARD CURB INLET PRECAST TOPS

W	PRE-CAST TOP SIZE	PIPE SIZE	cu m CONC.
1,321 m	1,121 x 3,450 m x 190 mm	525 mm & SMALLER	0.63±
1,625 m	1,425 x 3,450 m x 190 mm	600 & 750 mm	0.83±
1,930 m	1,730 x 3,450 m x 190 mm	900 & 1,050 mm	1.03±
2,235 m	2,035 x 3,450 m x 190 mm	1,200 & 1,350 mm	1.23±
2,540 m	2,340 x 3,450 m x 190 mm	1,500 & 1,650 mm	1.43±

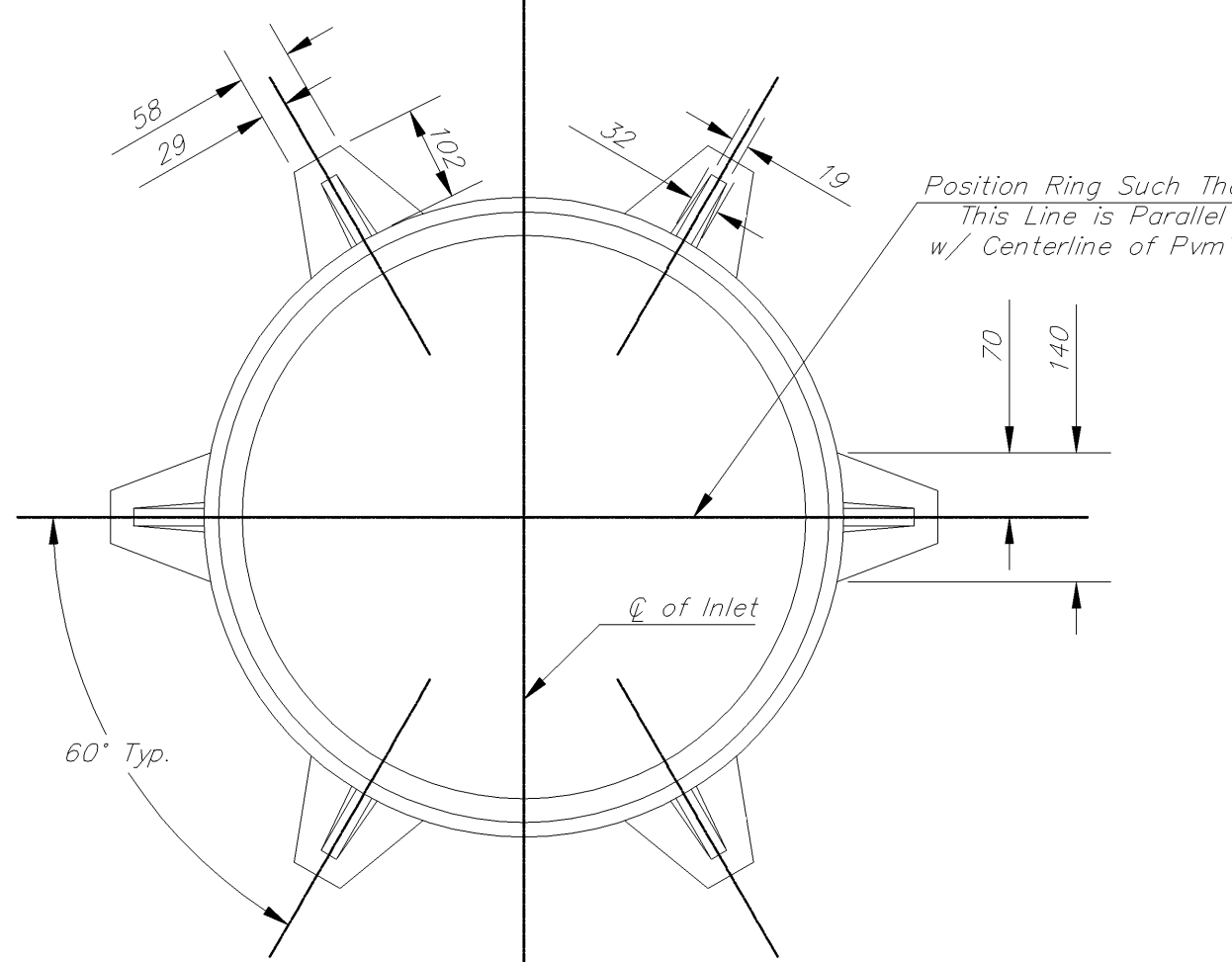

TYP1A-D.DWG

THE CITY OF WICHITA

STANDARD TYPE 1-A CURB INLET

OPENING = 150 x 3 000 mm

M. E. LINDEBAK P.E. - CITY ENGINEER

CITY ENGINEER'S OFFICE
 CITY HALL - SEVENTH FLOOR
 455 NORTH MAIN STREET
 WICHITA, KANSAS 67202
 (316) 268-4501
 (316) 268-4114 FAX

PROJECT NUMBER: _____ INDEX CODE: _____

DATE: MAR 96 SHEET 21 OF 54