

STRUCTURAL STEEL NOTES:

- STRUCTURAL STEEL SHALL MEET THE LATEST "CODE OF STANDARD PRACTICE FOR STEEL BUILDINGS AND BRIDGES," AND HAS BEEN DESIGNED IN ACCORDANCE WITH THE BUILDING CODE AND AISC "MANUAL OF STEEL CONSTRUCTION, ALLOWABLE STRESS DESIGN, 13TH EDITION."
- STRUCTURAL STEEL SHALL MEET THE FOLLOWING REQUIREMENTS UNLESS NOTED OTHERWISE ON THE DRAWINGS:
 

TYPE	ASTM	GRADE
W & WT SHAPES	A992	-----
M & S SHAPES, PLATES	A36	-----
CHANNELS & ANGLES	A36	-----
PIPE	A53	B TYPE E
HOLLOW STRUCTURAL SECTIONS (HSS)	A500	B (Fy = 46 KSI)
STRUCTURAL BOLTS	A325	-----
HEADED ANCHOR STUDS	A108	1015/1025
ANCHOR RODS (BOLTS)	F1554	36
- ALL BOLTED CONNECTIONS SHALL BE STANDARD AISC BEARING TYPE FRAMING CONNECTIONS. BOLTS SHALL BE SNUG-TIGHTENED, UNLESS NOTED OTHERWISE.
  - BEAM SHEAR CONNECTIONS SHALL BE STANDARD AISC DOUBLE ANGLE CONNECTIONS.
  - ALL BOLTED CONNECTIONS REQUIRING PRETENSIONED BOLTS SHALL USE DIRECT TENSION INDICATOR (DTI) WASHERS OR BOLTS (ASTM F1852) TO INSURE PROPER TENSIONING.
- ALL CONNECTIONS NOT DETAILED OR OTHERWISE NOTED SHALL BE DESIGNED BY THE FABRICATOR AND HIGHLIGHTED FOR THE ENGINEER OF RECORD'S REVIEW.
- ALL WELDING SHALL BE IN ACCORDANCE WITH LATEST AWS CODE, SECTION D1.1. ALL WELDS SHALL USE E70XX WELD MATERIAL.
- STEEL FRAMING MEMBERS SHALL ONLY BE SPLICED AT LOCATIONS AS SHOWN ON THE DESIGN DRAWINGS OR AS SHOWN AND APPROVED ON THE SHOP DRAWINGS.
- NO OPENINGS SHALL BE FIELD-CUT IN THE FLANGE OR WEBS OF STEEL MEMBERS WITHOUT THE APPROVAL OF THE ENGINEER, UNLESS NOTED OR DETAILED OTHERWISE.
- GALVANIZED STRUCTURAL STEEL SHALL CONFORM TO ASTM A123 FOR MEMBERS AND ASTM A153 FOR CONNECTION ELEMENTS. REPAIR ANY DAMAGED GALVANIZING COATING IN ACCORDANCE WITH ASTM A780.

GRATING NOTES:

- GRATING SHALL BE CONNECTED TO SUPPORTS PER MANUFACTURER'S RECOMMENDATIONS, USING ANCHOR AND CLIP ASSEMBLIES UNLESS NOTED OTHERWISE.
  - NO NOTCHING OR CUTTING OF BEARING BARS BEFORE WELDING IS PERMISSIBLE.
- ALUMINUM GRATING SHALL BE PRESSURE-LOCKED, RECTANGULAR DESIGN, TYPE B, AS MANUFACTURED BY IKG INDUSTRIES, A DIVISION OF HARSCO CORPORATION, OR APPROVED EQUAL. MAIN BARS TO BE THE SIZE SHOWN ON THE DETAILS, SPACED 1 3/16" CENTER-TO-CENTER. CROSS BARS SHALL BE RECTANGULAR CROSS SECTION, FLUSH TOP AND SPACED 4" O.C.. MAIN BARS AND CROSS BARS TO BE SLOTTED AT THEIR INTERSECTIONS SO AS NOT TO REMOVE EXCESSIVE MATERIAL AND HAVE THEIR SLOTS SOLIDLY FILLED BY THE CROSS BARS.

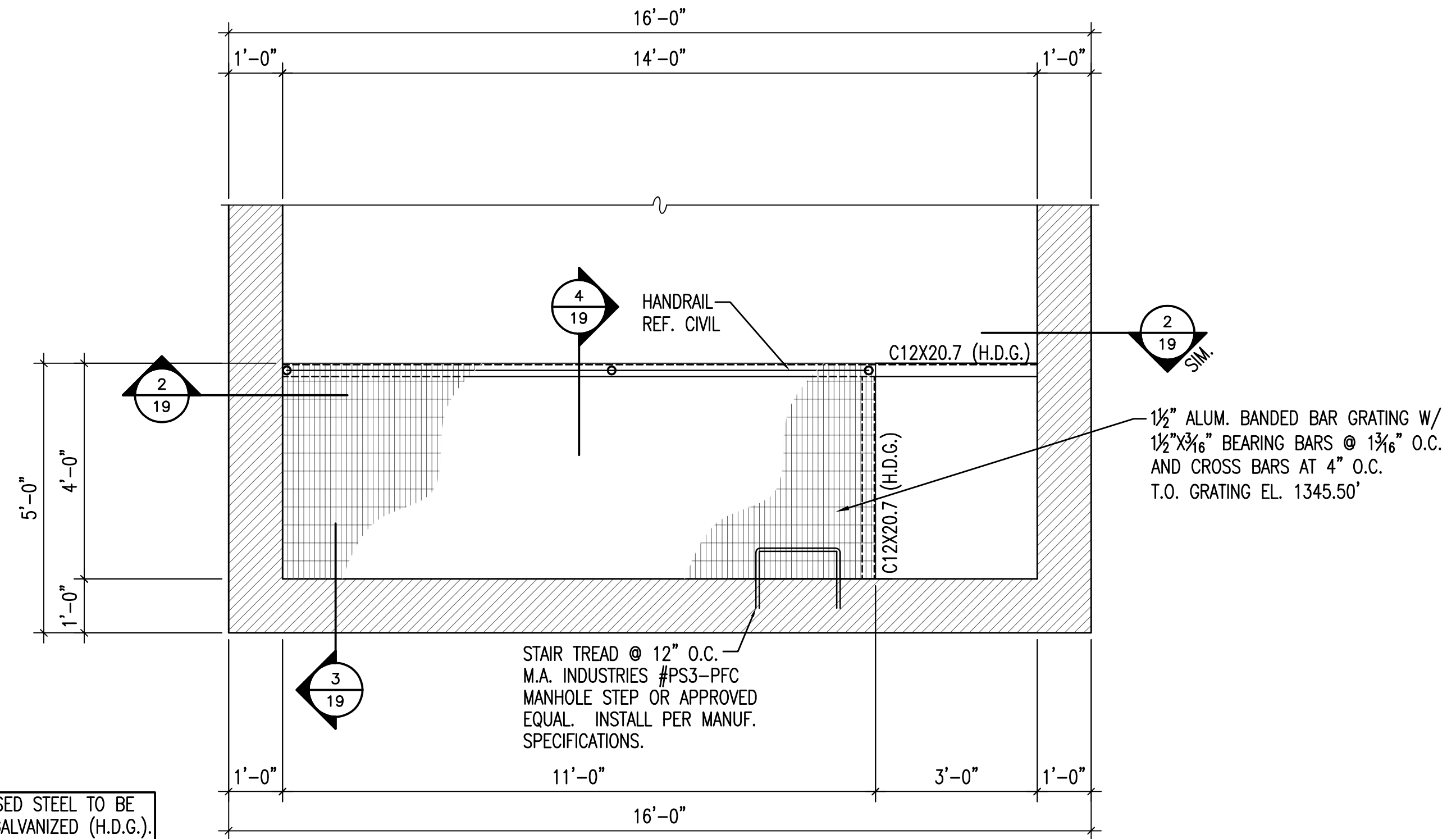

**NOTE:**  
ALL EXPOSED STEEL TO BE  
HOT DIP GALVANIZED (H.D.G.).

1 **CATWALK PLAN**  
1/2"=1'-0"

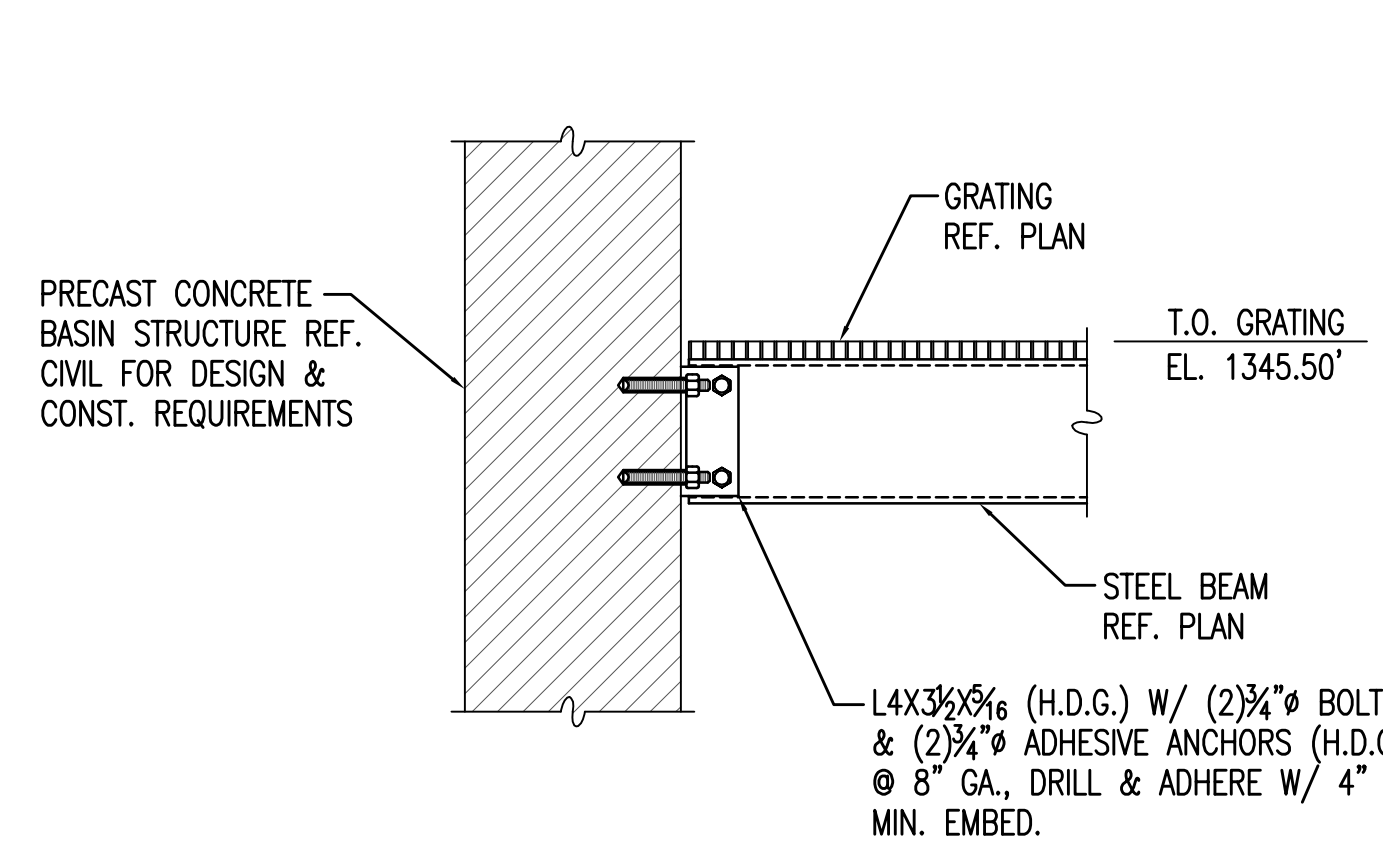

2 **EXT. WALL CATWALK SECTION**  
3/4"=1'-0"

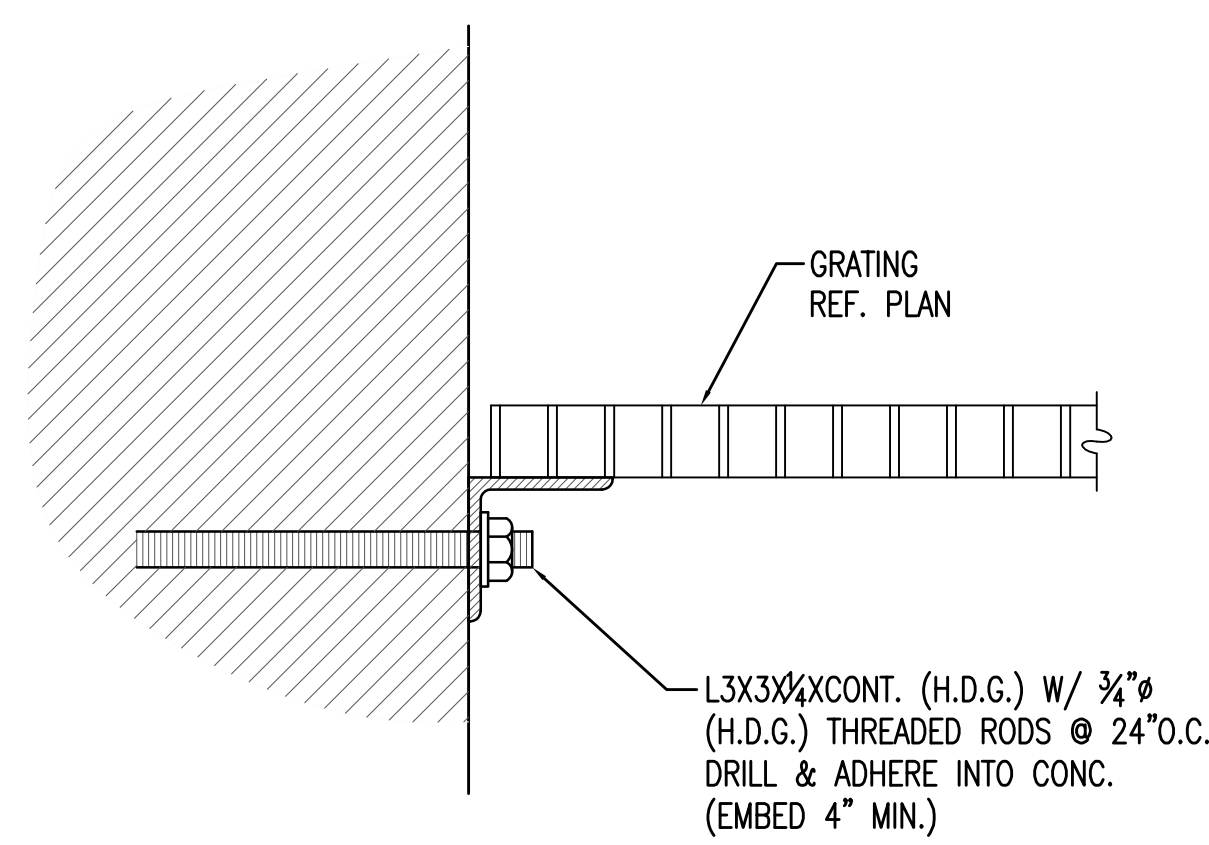

3 **GRATING SUPPORT DETAIL**  
3"=1'-0"

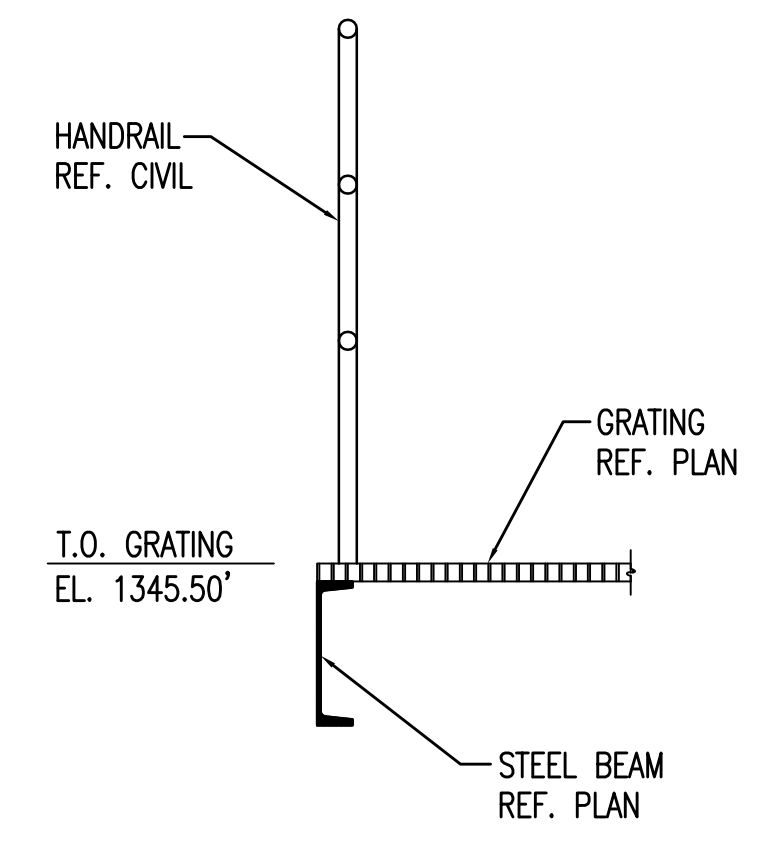

4 **CATWALK SECTION**  
3/4"=1'-0"

Saved: 09-29-2009 8:07:16 AM by: DGC  
 Plot Scale: 1/24 09-29-2009 11:23:24 AM  
 S:\2009\04274\00A\WESTY\RE-BID\04274-19-CATWALK-PLAN-DTLS

No.	Revision	By	Date
PHASE II - STORM WATER DRAIN #332 <b>WEST PUMP STATION</b> <b>ENLARGED CATWALK PLAN AND DETAILS</b> JAMES L. ARMOUR, P.E. - CITY ENGINEER CITY OF WICHITA PROJECT NO. 468-84396			
<b>Professional Engineering Consultants, P.A.</b> 303 S. TOPEKA • WICHITA, KANSAS 67202 316-262-2691 • FAX 316-262-3003			
Designed by	GB	Job No.	35-04274-042
Drawn by	DC	Date	SEPTEMBER 2009
			Sht. 19 of 63