

PERIMETER ROAD IMPROVEMENTS
BOTANICA - THE WICHITA GARDENS

N. PAV. PLAN
SHEET TITLE
472-84976
PROJECT NUMBER

DFL KKL/DM, JRA
DESIGNED DRAWN CHECKED

ISSUED
March 2011

REVISED

SHEET NO.
10 of 21

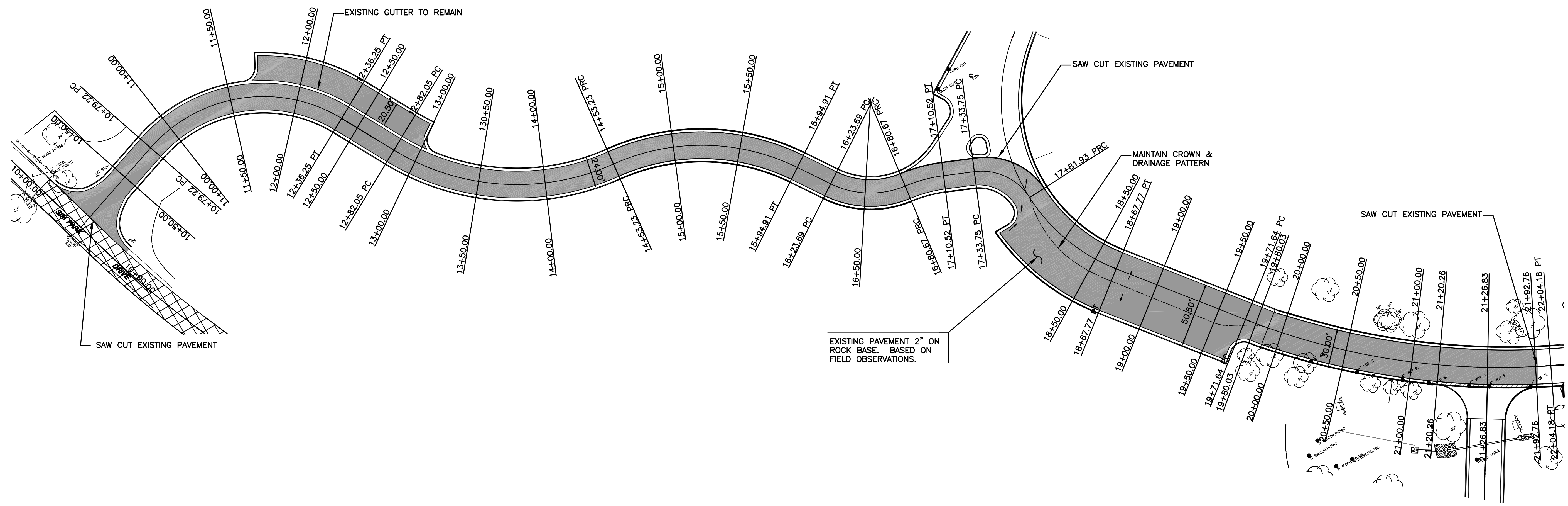

LEGEND

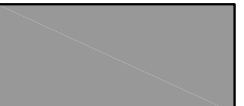
 REMOVE EXISTING PAVEMENT BETWEEN CURB & GUTTERS. REPLACE WITH 5" ASPHALT ON 5" ROCK BASE AND GEOGRID. SEE DETAIL "A" THIS SHEET.

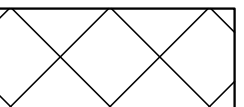
 MILL EXISTING ASPHALT OVERLAY. OVERLAY WITH 4" ASPHALT. SEE DETAIL "B" SHEET 9.

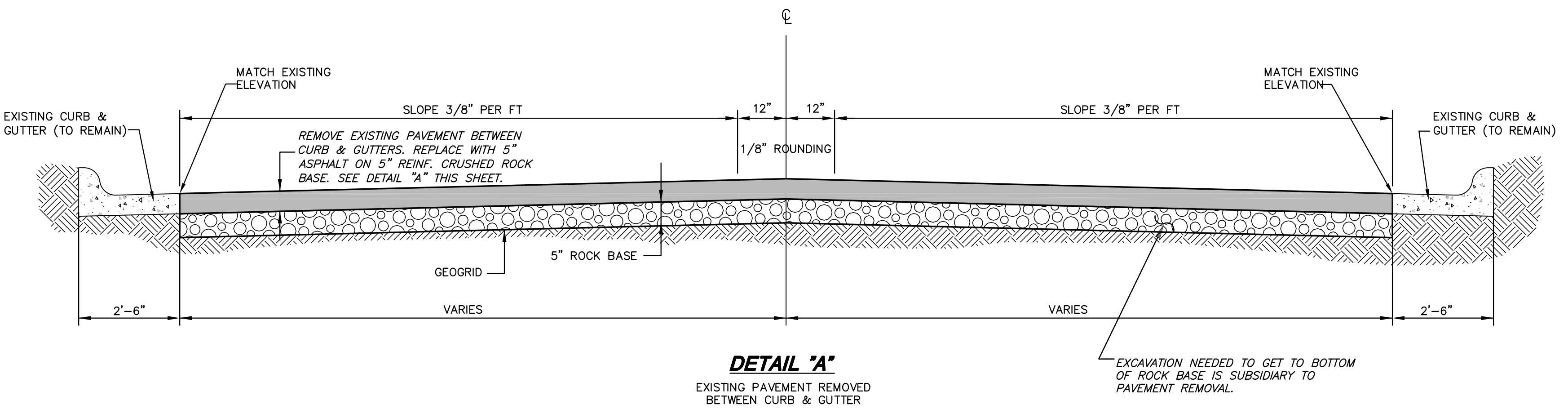

PLOTTED: Thursday, March 03, 2011 @ 11:42AM

J:\CIVIL\08603\DWG\PAV\BUS TURNAROUND\ SHEETS\08603_LE9.DWG